



**REGULAR MEETING
STRATEGIC PLANNING COMMITTEE
MONTECITO WATER DISTRICT
583 SAN YSIDRO ROAD, MONTECITO, CALIFORNIA
MONDAY, NOVEMBER 5, 2018
9:30 A.M.**

AGENDA

1) CALL TO ORDER, DETERMINATION OF COMMITTEE QUORUM

2) PUBLIC FORUM

NOTE: This portion of the agenda may be utilized by any person to address the Committee on any matter within the jurisdiction of the Committee. No consideration or discussion shall be undertaken by Committee members at this time on any item not appearing on this agenda except as permitted by the Ralph M. Brown Act. Discussion items receiving recommendations by the Committee, and/or items requiring action will be placed on the agenda of a future meeting of the Montecito Water District Board of Directors.

3) ITEMS FOR COMMITTEE CONSIDERATION

- A. Presentation of the draft Recycled Water Feasibility Plan

4) ADJOURNMENT

Note: This agenda was posted at the Montecito Water District front counter and outside front office at 9:30 a.m. on Friday, November 2, 2018. The Americans with Disabilities Act provides that no qualified individual with a disability shall be excluded from participation in, or denied the benefits of, the District's programs, services or activities because of any disability. If you need special assistance to participate in this meeting, please contact the District Office at 805/969-2271. Notification at least twenty-four (24) hours prior to the meeting will enable the District to make appropriate arrangements.

Materials related to an item on this agenda submitted to the Board's Strategic Planning Committee after distribution of the agenda packet are available for public inspection in the Montecito Water District offices located at 583 San Ysidro Road, Montecito, during normal business hours.

**MONTECITO WATER DISTRICT
MEMORANDUM**

SECTION: 3-A

DATE: NOVEMBER 5, 2018

TO: STRATEGIC PLANNING COMMITTEE

FROM: GENERAL MANAGER

SUBJECT: PRESENTATION OF DRAFT RECYCLED WATER FEASIBILITY PLAN

RECOMMENDATION:

Presented for Committee discussion.

DISCUSSION:

Attached for Committee discussion is the draft Recycled Water Facilities Plan prepared for the District by Woodard & Curran.

ATTACHMENTS:

Draft Recycled Water Facilities Plan, Woodard & Curran, November 2018



RECYCLED WATER FACILITIES PLAN

888 South Figueroa #1700
Los Angeles, CA 90017
213.223.9460

woodardcurran.com
COMMITMENT & INTEGRITY DRIVE RESULTS

0011083.00
Montecito Water
District
November 2018

State Water Resources Control Board
Montecito Water District Recycled Water Facilities Plan
Water Recycling Funding Program Project No. WRF 8361-110

Funding for this plan has been provided in part through an agreement with the State Water Resources Control Board. The contents of this document do not necessarily reflect the views and policies of the State Water Resources Control Board, nor does mention of trade names or commercial products constitute endorsement or recommendation for use.



TABLE OF CONTENTS

SECTION	PAGE NO.
EXECUTIVE SUMMARY	ES-1
1. INTRODUCTION.....	1
1.1 Report Background.....	1
1.2 Report Objectives	1
1.3 Planning Documents	1
2. PLAN SETTING.....	3
2.1 Study Area Characteristics	3
2.1.1 Land Use	3
2.1.2 Hydrologic Features.....	3
2.1.3 Groundwater Basins	3
2.1.4 Population Projections	8
2.2 Water Supply Characteristics and Facilities	8
2.2.1 Water Supplies	8
2.2.2 Water Supply Facilities	12
2.2.3 Water Quality	12
2.2.4 Water Demand Projections.....	14
2.2.5 Water Supply Projections	14
2.2.6 Potable Water Rates.....	15
2.3 Wastewater Characteristics and Facilities.....	16
2.3.1 Existing Facilities	16
2.3.2 Montecito WWTP	18
2.3.3 Summerland WWTP	20
2.3.4 El Estero WWTP.....	22
3. REGULATORY, PERMITTING, AND LEGAL REQUIREMENTS	24
3.1 Types of Reuse	24
3.2 Regulatory Overview	24
3.3 SWRCB Regulations	26
3.3.1 Non-Potable Reuse Regulations.....	26
3.3.2 Groundwater Replenishment Reuse Regulations.....	26
3.3.3 Reservoir Water Augmentation Regulations.....	29
3.3.4 Direct Potable Reuse Regulations	29
3.4 State Water Resources Control Board Policies	32
3.4.1 Anti-degradation Policies	33
3.4.2 Recycled Water Policy.....	33
3.5 Central Coast RWQCB Requirements	34
3.6 Permitting Recycled Water Projects	34
3.6.1 Non-Potable Projects.....	34
3.6.2 Groundwater Replenishment Reuse Projects.....	35
3.6.3 Effluent Rights	35
4. RECYCLED WATER MARKET	36
4.1 Non-Potable Reuse Market	36

4.1.1	Landscape Irrigation	36
4.1.2	Agricultural Irrigation	40
4.2	Groundwater Augmentation.....	41
4.2.1	Storage Capacity	41
4.2.2	Travel Time.....	42
4.2.3	Conclusions	42
5.	ALTERNATIVES DEVELOPMENT & ANALYSIS.....	44
5.1	Recycled Water Supply Options.....	44
5.1.1	MSD WWTP Supply	44
5.1.2	SSD WWTP Supply	45
5.1.3	City of Santa Barbara	46
5.1.4	Summary of Recycled Water Supplies	47
5.2	Recycled Water Alternatives Development	47
5.2.1	Planning and Design Assumptions	50
5.2.2	Alternatives Cost Estimate Basis	51
5.3	Alternatives Definition.....	53
5.3.1	Non-Potable Reuse Alternatives.....	57
5.3.2	Indirect Potable Reuse (Groundwater Augmentation) Alternatives.....	60
5.3.3	Direct Potable Reuse Alternatives	65
5.3.4	Non-Recycled Water Alternative.....	66
5.3.5	Summary of Alternatives Evaluation	67
5.4	Top Alternatives Definition and Evaluation.....	67
5.4.1	Top Alternatives Definition.....	68
5.4.2	Top Alternatives Evaluation	69
5.4.3	Future Projects	72
5.4.4	Sensitivity Analysis	72
5.4.5	Other Considerations	73
6.	RECOMMENDED PROJECT	75
6.1	Facilities	75
6.2	Recommended Project Cost Estimate.....	78
7.	IMPLEMENTATION PLAN	79
7.1	Institutional Needs.....	79
7.1.1	Interagency/Customer Agreements	79
7.1.2	Permitting.....	79
7.1.3	Right of Way Acquisition.....	79
7.2	Funding Opportunities	79
7.2.1	Integrated Regional Water Management (IRWM) Program Funding.....	79
7.2.2	US Bureau of Reclamation (USBR) WaterSMART: Title XVI – Grant Funding.....	80
7.2.3	SWRCB CWSRF/ Water Recycling Funding Program (WRFP).....	80
7.2.4	Infrastructure State Revolving Fund (ISRF) Program – I-Bank.....	82
7.3	Financing Plan.....	82
7.3.1	Recycled Water Pricing.....	82
7.4	Technical Studies	83
7.4.1	MSD WWTP Flows and Discharges	83
7.4.2	Top Customer Commitments.....	83
7.5	Environmental Review.....	84

7.6	Engineering, Design, and Construction Activities	84
7.6.1	Ocean Outfall Assessment	84
7.6.2	Pre-Design Report	84
7.6.3	Final Design	84
7.6.4	Bidding/Contract Award, Construction, and Startup	85
7.7	Implementation Schedule	85
7.8	Future Phases	85
7.8.1	Montecito Basin Hydrogeologic Investigation	85
8.	CONCLUSION	87
9.	REFERENCES	88

APPENDICES

- Appendix A: Non-Potable Demand Estimates
- Appendix B: Alternatives, Detailed Cost Estimates
- Appendix C: Top Alternatives, Detailed Cost Estimates

TABLES

Table 1: Montecito Basin Annual Safe Yield by Storage Unit	7
Table 2: Summary of Recent Groundwater Pumping, AFY.....	7
Table 3: Historic and Projected Population	8
Table 4: Existing Source Water Quality for Irrigation Constituents	12
Table 5: Historical Water Use, 2011-2017 (AFY)	14
Table 6: Water Demand Projections (AFY)	14
Table 7: Potable Water Rates	16
Table 8: Existing Wastewater Treatment Plants Capacity and Flows	18
Table 9: MSD Annual Dry Weather Effluent Flows, 2011-2017 (MGD).....	19
Table 10: Montecito WWTP Effluent Limitations	20
Table 11: Average 2017 Montecito WWTP Wastewater Effluent Quality.....	20
Table 12: SSD Annual Dry Weather Flows, 2011-2017 (MGD)	21
Table 13: Summerland WWTP Effluent Limitations	22
Table 14: Average 2017 Summerland WWTP Wastewater Effluent Quality	22
Table 15: Key California Statutes for Protection of Water Quality and Public Health.....	25
Table 16: Title 22 Groundwater Recharge Regulations	26
Table 17: Irrigation Demand Estimates from Metered Potable Water Use.....	36
Table 18: Recycled Water Customers (> 5 AFY), Landscape Irrigation.....	38
Table 19: Comparison of Turfgrass Irrigation Water Quality Guidelines for Salinity.....	39
Table 20: Available Storage Capacity during the 1991 Drought	41
Table 21: Non-Potable Reuse Alternatives, Recycled Water Supplies	47
Table 22: Facilities Criteria and Hydraulic Criteria	50
Table 23: Alternatives, Unit Cost Assumptions	52
Table 24: Recycled Water Alternatives Summary Matrix	53
Table 25: NPR Alternatives, Summary	57
Table 26: NPR Alternatives, Potential Recycled Water Customers	58
Table 27: NPR Alternatives, Cost Summary	60
Table 28: IPR Alternatives, Summary	61
Table 29: IPR Alternatives, Cost Summary	64
Table 30: Direct Potable Reuse Alternatives, Summary	65
Table 31: DPR Alternatives, Cost Summary	66
Table 32: Top Alternatives, Facilities	68
Table 33: Top Alternatives, Cost Estimates	69
Table 34: Top Alternatives, Qualitative Assessment Summary	71
Table 35: Alternative B (Large NPR), Sensitivity Analysis	73
Table 36: Recommended Project, Recycled Water Customers	75
Table 37: Recommended Project, Design Criteria	78
Table 38: Recommended Project Costs	78

FIGURES

Figure 1: Study Area	4
Figure 2: Land Use within MWD Service Area	5
Figure 3: Study Area Groundwater Basins	6
Figure 4: Montecito Water District Water Supplies	9
Figure 5: MWD Major Water Supply Facilities	13
Figure 6: Existing Wastewater and Recycled Water Facilities in the Study Area	17
Figure 7: Montecito WWTP Flow Schematic	18
Figure 8: Montecito WWTP Average Effluent Monthly Flows	19
Figure 9: Summerland WWTP Flow Schematic	21
Figure 10: Summerland WWTP Average Effluent Monthly Flows	21
Figure 11: Existing Recycled Water Facilities	23
Figure 12: Example Potable Reuse Treatment Trains	30
Figure 13: Recycled Water Customers in MWD Service Area	37
Figure 14: Birnam Wood Area Wells	43
Figure 15: Recycled Water Treatment Requirement Assumptions	44
Figure 16: Potential Recycled Water from the City of Santa Barbara	47
Figure 17: Example Monthly Seasonal Irrigation Demand	49
Figure 18: MSD WWTP Diurnal Flow, Average for July 1 to July 31, 2018	51
Figure 19: Non Potable Reuse Alternatives	54
Figure 20: Indirect Potable Reuse Alternatives	55
Figure 21: Direct Potable Reuse Alternatives	56
Figure 22: NPR Alternatives, System Schematics	57
Figure 23: NPR Alternatives, Capital Costs (\$M)	59
Figure 24: NPR Alternatives, Unit Costs (\$/AF)	59
Figure 25: Indirect Potable Reuse Alternatives, System Schematics	61
Figure 26: IPR Alternatives, Capital Costs (\$M)	63
Figure 27: IPR Alternatives, Unit Costs (\$/AF)	63
Figure 28: Direct Potable Reuse Alternatives, System Schematics	65
Figure 29: Recommended Project, Preliminary WRF Layout	76
Figure 30: Recommended Project, Distribution System and Customers	77
Figure 31: Construction Financing and Revenue Plan Basis	82
Figure 32: Implementation Schedule for Recommended Project	85

LIST OF ABBREVIATIONS

AF	acre-foot
AFY	acre-feet per year
AOP	advanced oxidation process
AWT	advanced water treatment
AWTF	advanced water treatment facility
BAC	biological activated carbon
Basin	Montecito Groundwater Basin
Basin Plan	Water Quality Control Plan for the Central Coastal Basin
BNR	biological nitrogen removal
CCI	Construction Cost Index
CCR	California Code of Regulations
CCWA	Central Coast Water Authority
CDP	census designated place
CEC	constituents of emerging concern
CEQA	California Environmental Quality Act
Cl	chlorination
City	City of Santa Barbara
CVWD	Carpinteria Valley Water District
CWC	California Water Code
DDW	SWRCB Division of Drinking Water
DPR	direct potable reuse
DWR	California Department of Water Resources
ECw	electrical conductivity of water
ENR	Engineering News Record
Facilities Plan	Recycled Water Facilities Plan
gpm	gallons per minute
GWA	groundwater augmentation
GWMP	Groundwater Management Plan
GRRP	groundwater replenishment reuse project
HCF	hundred cubic feet
H&SC	Health and Safety Code
IPR	indirect potable reuse
hp	horsepower
kWh	kilowatt-hour
MF	microfiltration
MGD	million gallons per day
mL	milliliters
MPN	most probable number
MSD	Montecito Sanitary District
MWD	Montecito Water District
NPDES	National Pollutant Discharge Elimination System
NTU	Nephelometric Turbidity Units
O&M	Operations and Maintenance
O ₃	ozone
RO	reverse osmosis
RRT	response retention time
RWA	raw water augmentation

RWC	recycled water contribution
RWQCB	Regional Water Quality Control Board
SAR	sodium adsorption ratio
SAT	soil aquifer treatment
SBCAG	Santa Barbara County Association of Governments
SFR	single- family residential
SGMA	Sustainable Groundwater Management Act
SRF	State Revolving Fund
SRP	Stormwater Resources Plan
SSD	Summerland Sanitary District
SWP	State Water Project
SWRCB	State Water Resources Control Board
SWTP	Surface Water Treatment Plant
TDS	total dissolved solids
TOC	total organic carbon
TDWA	treated drinking water augmentation
UF	ultrafiltration
USBR	United State Bureau of Reclamation
UV	ultraviolet light
WDR	Waste Discharge Requirements
WRF	water reclamation facility
WRFP	Water Recycling Funding Program
WRR	Water Recycling Requirements
WWTP	wastewater treatment plant

EXECUTIVE SUMMARY

Given the long-term risks and decreased reliability associated with the State Water Project and local surface water supplies, the Montecito Water District is committed to pursuing local, drought proof supplies. The District is committed to achieving 85% local, reliable drought proof supplies by 2025, including District groundwater, Doulton tunnel infiltration, locally or regionally imported/purchased water, local or regional banked water, and recycled water. The District's 2015 Urban Water Management Plan Update targets the delivery of 200 AFY of recycled water to District customers by 2020 and a total of 1,000 AFY by 2025. The purpose of this report is to investigate feasible recycled water projects. Depending on the results of the Study, the quantities and timing of these deliveries may change.

The Recycled Water Facilities Plan considers three recycled water sources (Montecito Sanitary District (MSD), the City of Santa Barbara (City or SB), and Summerland Sanitary District (SSD) for non-potable reuse (NPR), indirect potable reuse (IPR), and direct potable reuse (DPR) opportunities at multiple project locations. The Executive Summary presents the NPR, IPR, and DPR alternatives, the top alternatives, and the recommend alternative. The figures at the end of the Executive Summary present the NPR, IPR, and DPR alternatives and the recommended alternative.

Recycled Water Supplies

Source	Existing Treatment	Existing Flow	Available Flow	Existing TDS Concentration	Target NPR TDS Concentration ⁽¹⁾
MSD	Secondary	0.5 MGD (560 AFY)	0.4 MGD (450 AFY) to 0.6 MGD (670 AFY) ⁽²⁾	1,500 mg/L ⁽³⁾	800 mg/L
SSD ⁽⁴⁾	Secondary	0.1 MGD (110 AFY)	0.1 MGD (110 AFY)	1,200 mg/L ⁽³⁾	800 mg/L
City ⁽⁵⁾	Tertiary	~3 MGD (3,360 AFY)	1 MGD (Summer) to 2.5 MGD (Winter) (2,000 AFY)	1,000 mg/L	Existing

Notes:

- The target is based on existing groundwater TDS concentrations. MSD NPR options assumes RO treatment of roughly 50% of flow is assumed to reduce TDS from 1,500 mg/L to 800 mg/L. SSD NPR options assume RO treatment of roughly 35% of flow is assumed to reduce TDS from 1,200 mg/L to 800 mg/L.
- Existing MSD WWTP flows are approximately 0.5 MGD. Recovery to pre-disaster flows of roughly 0.6 MGD is assumed in the near future. Also, MSD estimates the need to maintain a minimum flow of 0.1 MGD to the ocean outfall. Therefore, available MSD flows could be as low as 0.4 MGD. The minimum discharge, if any, must be determined to maximize use of available flows.
- MSD and SSD effluent TDS concentrations were analyzed using method EPA Method 200.1 while MWD groundwater TDS concentrations, which are the basis for the target TDS, were reported using Standard Method 2540. The EPA method report TDS by Summation and tends to be 10% to 20% higher so the MSD and SSD TDS concentrations were reduced by 15% for comparison with the target TDS concentration.
- Use of all SSD flows will result in low to no discharges during portions of the year. The minimum discharge, if any, must be determined to maximize use of available flows.
- A recycled water purchase price of \$2,600/AF is assumed for all City projects based on input from the City. The recycled water availability changes seasonally based on the City's use of recycled water, which is highest in the summer during the peak irrigation season. Addition of desalinated water to the City's potable water supply has decreased existing TDS from 1,400 to 1,000 mg/L; therefore, additional RO is not included.

Non-Potable Reuse Alternatives

Project	Additional Treatment Required	Treatment Capacity (MGD)	No. of Customers	Yield (AFY)
MSD				
NPR MSD1: Santa Barbara Cemetery	UF + 50% RO ⁽¹⁾	0.14	1	80
NPR MSD2: NPR 1 to Biltmore	UF + 50% RO ⁽¹⁾	0.20	5	112 ⁽²⁾
NPR MSD3: NPR 2 to Golf Courses	UF + 50% RO ⁽¹⁾	0.54	8	367 ⁽²⁾
<i>NPR MSD3 Extensions</i>				
NPR MSD3a: MSD3 to Manning Park	UF + 50% RO ⁽¹⁾	0.54	10	371
NPR MSD3b: MSD3 to Westmont	UF + 50% RO ⁽¹⁾	0.54	12	390
NPR MSD3c: MSD3 to Agriculture	UF + 50% RO ⁽¹⁾	0.54	9	404
City of Santa Barbara ⁽³⁾				
NPR SB1: Santa Barbara Cemetery	N/A ⁽⁴⁾	N/A	1	80
NPR SB2: NPR 1 to Biltmore	N/A ⁽⁴⁾	N/A	5	112 ⁽²⁾
NPR SB3: NPR 2 to Golf Courses	N/A ⁽⁴⁾	N/A	8	367 ⁽²⁾
SSD				
NPR SSD1: Local Irrigation	UF + 35% RO ⁽¹⁾	0.01	1	4
NPR SSD2: Max Irrigation	UF + 35% RO ⁽¹⁾	0.10	4	70 ⁽²⁾

Notes:

- RO is required to meet target TDS concentrations for NPR of 800 mg/L to match existing groundwater supplies.
- Includes demands that are included in upstream alternatives. For example, NPR MSD2 includes NPR MSD1 demands.
- Santa Barbara alternatives SB1, SB2, and SB3 serve the same customers as MSD1, MSD2, and MSD3, respectively.
- Santa Barbara recycled water uses UF for tertiary filtration and has a TDS concentration of roughly 1,000 mg/L.

NPR Alternatives, Unit Costs (\$/AF)

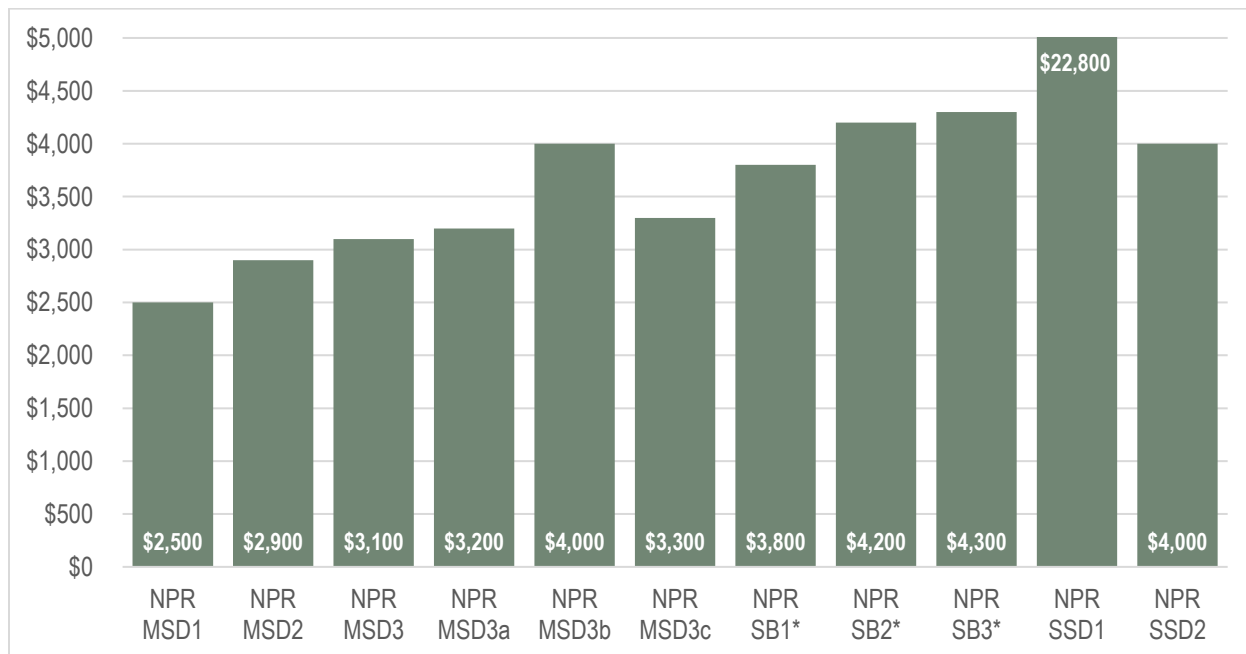

Note: Unit costs include annual O&M and annualized capital cost assuming SRF financing of 2.0% interest rate over 30 years.

* Includes City (SB) recycled water purchase price of \$2,600/AF.

Indirect Potable Reuse Alternatives

Project	Source	AWTF Location	Treatment Capacity	Yield (AFY)
IPR1: Injection in Montecito Basin				
IPR MSD1	MSD	MSD	0.5 MGD	540
IPR MSD1 + NPR MSD3 Combo	MSD	MSD	0.5 MGD	IPR: NPR:
IPR SB1a	City RW	To be determined	1.0 MGD	1,100
IPR SB1b	City WW		1.0 MGD	1,100
IPR MSD/SB1	MSD & City RW	MSD	1.0 MGD	1,100
IPR2: Injection in Toro Canyon Sub-basin				
IPR MSD2	MSD	MSD	0.5 MGD	540
IPR SSD2	SSD	SSD	0.08 MGD	90
IPR3: Injection in Carpinteria Basin				
IPR MSD3a (MSD AWTF)	MSD	MSD	0.5 MGD	540
IPR MSD3b (MSD WW to CSD AWTF)	MSD	CSD		540
IPR4: Regional Partnership				
IPR 4: Carpinteria, IPR Project	CSD	CSD	1.0 MGD	540

Note: All alternatives are groundwater augmentation via injection. IPR alternatives with MSD or SSD apply advanced water treatment (AWT), which consists of UF, RO, and advanced oxidation process (AOP). IPR alternatives using the City's recycled water excludes UF as part of a new AWT process since their tertiary treatment process already includes UF.

IPR Alternatives, Unit Costs (\$/AF)

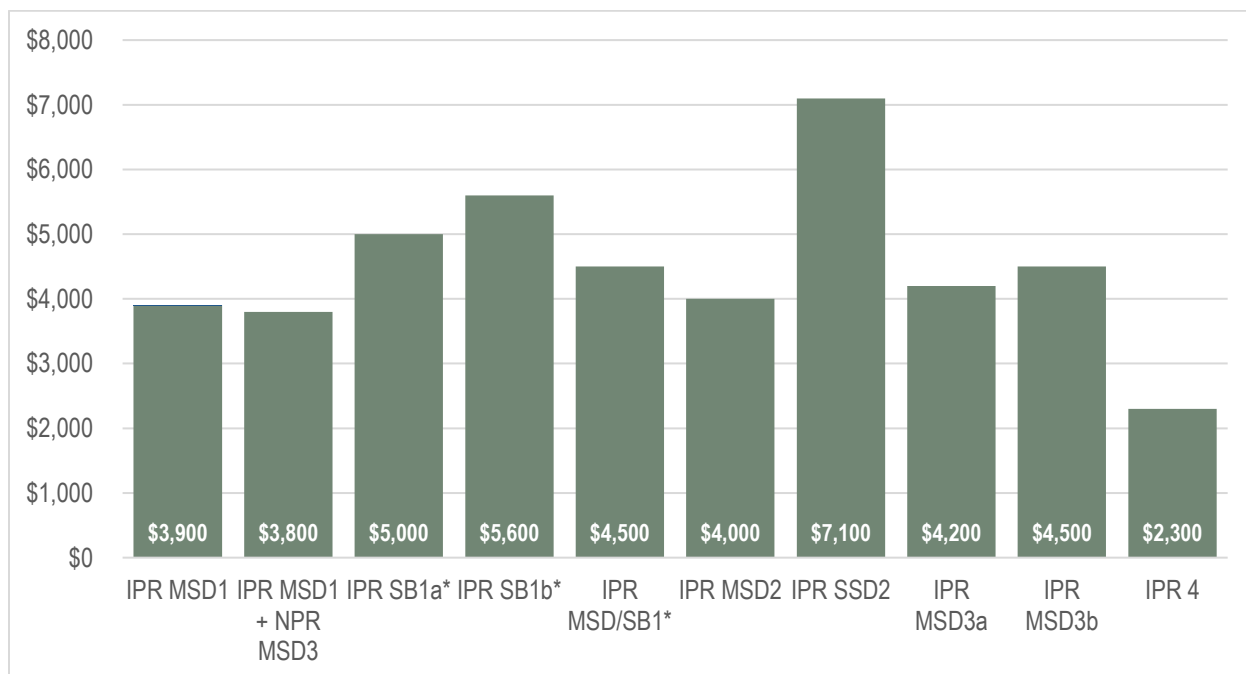

Note: Unit costs include annual O&M and annualized capital cost assuming SRF financing of 2.0% interest rate over 30 years.
*Includes City (SB) recycled water purchase price of \$2,600/AF.

Direct Potable Reuse Alternatives

Project ⁽¹⁾	Source & Treatment Location	Level of Treatment ⁽²⁾	Treatment Capacity	Pipe Diameter & Length	Yield (AFY)	Unit Cost (\$/AF) ⁽³⁾
DPR 1: RWA at Bella Vista WTP	MSD WWTP	AWT+	0.5 MGD	10" @ 31,200 ft	540	\$4,300
DPR 2: TDWA at Romero Reservoir	MSD WWTP	AWT++	0.5 MGD	10" @ 26,700 ft	540	\$4,700
DPR 3: TDWA at Distribution System	MSD WWTP	AWT++	0.5 MGD	10" @ 6,700 ft	540	\$4,000
DPR 4: City RWA Project Partnership	City WWTP	AWT+	6.2 MGD	12" @ 11,500 ft 16" @ 14,000 ft	540 (of 6,300) ⁽⁴⁾	\$2,900 ⁽⁴⁾

Notes:

1. Raw water augmentation (RWA) is "AWT+" water conveyed to a surface water treatment plant for treatment and distribution. Treated drinking water augmentation (TDWA) is "AWT++" water conveyed directly to the potable distribution system.
2. "AWT+" = AWT (UF/RO/AOP) plus an additional disinfection step; "AWT++" = AWT+ plus ozone and BAC.
3. Unit costs include annual O&M and annualized capital cost assuming SRF financing of 2.0% interest rate over 30 years.
4. DPR 4 yield for MWD is undetermined so a similar yield as the other DPR projects was assumed. The full project is estimated to produce 6,300 AFY. Cost assumes MWD would fund 9% of the overall project (based on 540 AFY for MWD of 6,300 AFY project). Does not include any cost for water purchase or exchange

Alternatives Comparison

The purpose of the alternatives analysis is an initial comparative evaluation primarily based on cost so that the top alternatives can be identified for more detailed definition and evaluation. The following recommendations were made based on the alternatives definition and analysis:

- NPR MSD1 (Cemetery) and MSD3 (Golf Courses) are the top NPR alternatives.
- IPR MSD1 (Montecito Basin) and IPR4 (Carpinteria IPR Project Partnership) are the top IPR alternatives.
- DPR projects are not recommended at this time due to a lack of regulations and associated unknowns with the necessary capital and O&M costs but should be considered as a potential future phase.
- NPR MSD 3a (Manning Park Extension), MSD3c (Agricultural Extension), and SSD2 (Max SSD Irrigation) are a second tier of NPR projects that could be pursued in addition to the top NPR alternatives.
- IPR MSD1 is preferred over IPR MSD2 (Toro Canyon Sub-basin) since Montecito Basin has better IPR operational characteristics (MWD groundwater rights, storage capacity, existing MWD wells, limited private wells) than Toro Canyon Sub-basin. Although, the feasibility of groundwater augmentation in the Montecito Basin and Toro Canyon Sub-basin must be investigated with a hydrogeologic study.
- Alternatives with City supplies have higher unit costs than those with MSD supplies. A 40 to 50 percent lower price than the current price of \$2,600/AF would be more competitive with MSD supplies.
- IPR 4 (Carpinteria IPR Project Partnership) potentially has a low unit cost but must be discussed further with CVWD. This alternative could be pursued in parallel with other preferred alternatives since it does not impact use of MSD, SSD, or City wastewater.
- The MWD 2015 UWMP recycled water goal of 1,000 AFY by 2025 exceeds available recycled water supplies within MWD service area. Projects both within and outside of the service area are needed to meet this goal.
- Projects could be implemented in phases, such as NPR and then IPR and/or DPR (once regulations are developed).

The findings and recommendations include the following substantial qualifications:

- MSD flows are assumed to increase from current flows of 0.5 MGD to 0.6 MGD in the next few years and the minimum ocean discharge of 0.1 MGD is assumed to decrease to 100% RO concentrate in some scenarios.
- NPR alternatives assume customers will take recycled water at the proposed quality and price (TBD) to meet their estimated recycled water demand. Increased RO to improve water quality will increase project costs.
- IPR alternatives in the Montecito Basin and Toro Canyon Sub-basin require a groundwater investigation to confirm project feasibility.
- Regional partnership with CVWD requires further evaluation by CVWD of the cost and risk of providing water exchange deliveries.

Top Alternatives

Based on the alternatives evaluation, four top alternatives were selected for more detailed evaluation:

- **Alt A – Small NPR:** NPR MSD1 – Santa Barbara Cemetery from MSD WWTP
- **Alt B – Large NPR:** NPR MSD3 – Golf Courses from MSD WWTP
- **Alt C – Montecito Basin IPR:** IPR MSD1 – Montecito Basin Groundwater Augmentation from MSD WWTP
- **Alt D – Carpinteria IPR Partnership:** IPR 4 – Carpinteria IPR Project Partnership

There are several variations of these projects and second tier projects that can also be considered as a future phase. These include:

- **NPR MSD2 – Biltmore Extension** – consider if NPR system is not extended to the golf courses (Alt B) and customers express interest in recycled water use.
- **NPR MSD3a – Manning Park Extension** – consider if sufficient supply is available and customers express interest in recycled water use.
- **NPR MSD3c – Private Agricultural Extension** – consider if sufficient supply is available and customer expresses interest in recycled water use. Potential conversion of the agricultural use to large rural residential parcels was noted.
- **NPR SSD2 – Max Irrigation** – consider if customers express interest in recycled water use. One of the main customers is a private residence.
- **City Recycled Water** – the top alternatives could be supplemented with recycled water from the City of Santa Barbara if the demand materializes and the amount of use can justify the cost to connect to the City's system.
- **DPR 1 – Raw Water Augmentation at Bella Vista WTP** – re-consider this project once RWA regulations are developed in 2023 and consider that Alt B (golf courses) infrastructure could be used for conveyance and extended to Bella Vista WTP.
- **DPR 4 – City of Santa Barbara Raw Water Augmentation (Cater WTP)** – re-consider this project once RWA regulations are developed in 2023 and if the City of Santa Barbara chooses to pursue the project.

Top Alternatives, Cost Estimates (\$M)

Component	Alt A: Small NPR (NPR MSD1)	Alt B: Large NPR (NPR MSD3)	Alt C: Montecito Basin IPR (IPR MSD1)	Alt D: Carpinteria IPR Partnership (IPR 4) ⁽¹⁾
Construction Cost	\$4.2	\$12.6	\$24.0	\$21.4
Implementation Costs	\$1.1	\$3.2	\$7.2	\$6.4
Total Estimated Capital Cost	\$5.2	\$15.8	\$31.2	\$27.8
Annualized Capital Costs				
Annualized Capital Costs	\$0.2	\$0.7	\$1.4	\$1.2
Total Annual O&M	\$0.2	\$0.5	\$0.7	\$1.2
Total Annualized Cost	\$0.4	\$1.2	\$2.1	\$2.4
Project Unit Costs				
Recycled Water Yield (AFY)	80	367	540	1,100 ⁽¹⁾
Project Unit Cost (\$/AF)	\$5,300 ⁽²⁾	\$3,300	\$3,900	\$2,200

Note:

1. The total project yield is 1,100 AFY. The MWD partnership with CVWD is subject to negotiation regarding the yield and cost to exchange the project water with water from Cater WTP.
2. The cost of Alt A roughly doubled from the alternative definition due to multiple factors. The primary factors are that: 1) the treatment facilities lose economies of scale at this size – it’s 1/3 the size of Alt B but is 60% of the capital cost based on vendor quotes; 2) the treatment plant footprint (and associated concrete and building costs) are relatively high compared to the treatment capacity; and 3) much of the annual O&M is for operator labor, which may be covered by existing MSD/MWD staff but has not been determined.

Based on cost and qualitative assessments, the following conclusions were made:

- Alternatives A, B, and C would all use recycled water from MSD WWTP and are therefore mutually exclusive.
- **Alternative B** is recommended over Alternative A and Alternative C due to the lower unit cost and better qualitative assessment.
- **Alternative A** could be implemented as a first phase of Alternative B but is not recommended on its own due to the high unit cost.
- **Alternative C** could ultimately result in more yield than Alternative B but cannot be recommended until a hydrogeological evaluation determines the ability to operate the IPR project with the estimated yield and meeting regulatory requirements.
- **Alternative D** is recommended for further consideration due to having the lowest unit cost. However, the alternative does have potential institutional and public hurdles to overcome. Also, MWD must work with CVWD to determine the cost and terms of the water exchange involves multiple factors. The water exchange cost is not included.

Recommended Project

The Recommended Project (Alt B; NPR MSD3) involves the construction of a new 0.6 MGD water reclamation facility (WRF) at the MSD WWTP and recycled water distribution system. The recommended WRF includes secondary equalization, UF membranes, RO membranes (for portion of flow), and UV disinfection. The recycled water distribution system includes a recycled water storage tank, recycled water pump station, and approximately 21,000 LF of 12-inch diameter pipeline to various customers. The distribution system and customers for the Recommended Project is illustrated in the figure at the end of the Executive Summary.

The Recommended Project would deliver roughly 370 AFY of recycled water for irrigation. MWD has the option to expand the treatment facilities to conduct advanced water treatment (UF/RO/AOP) on all flow in the future if groundwater recharge with recycled water is deemed feasible and cost effective. Similarly, direct potable reuse could be pursued in the future once regulations are established and the concepts are re-considered. Also, MWD would be able to import recycled water from the City of Santa Barbara to supplement MSD recycled water in the future if demands and cost justify the addition.

A list of recycled water customers for the Recommended Project and their respective estimated average annual demands is presented in the following table. The next table summarizes the Recommended Project estimated cost.

Recommended Project, Recycled Water Customers

Customer	Recycled Water Demand Estimate	
	Avg Annual (AFY)	Max Day (MGD)
Valley Club Montecito	150	0.27
Birnam Wood Golf Club	100	0.18
Santa Barbara Cemetery	80	0.14
Four Seasons Biltmore	15	0.03
Miramar Hotel	11	0.02
Private Residence	9	0.02
Ty Warner Hotels	6	0.01
Music Academy of West	2	0.004
Total	373	0.67
Maximum Yield with Available MSD Supply	367	0.54

Note: Maximum yield with available MSD supply is limited by the available recycled water – estimated as 0.54 MGD – so only a portion of potential irrigation demand will be met with recycled water. For comparison purposes, City alternatives are assumed to be limited to this volume too.

Recommended Project Costs

Total Estimated Capital Cost	\$15,800,000
Annual Costs	
Annualized Capital Costs	\$703,500
Annual O&M	\$500,000
Total Annualized Cost	\$1,203,500
Project Unit Costs	
Recycled Water Yield (AFY)	367
Project Unit Cost (\$/AF)	\$3,300

Implementation Schedule

The overall implementation plan for the Recommended Project is shown below. Full implementation of the project is anticipated to take approximately 3 years. From a project funding and financing perspective, CEQA certification is the critical path for gaining preliminary approval for grant funding and low-interest loans from the SWRCB. From a project start-up perspective, technical studies and design make up the critical path. CEQA certification is also needed before the RWQCB can issue the tentative permit. The recommended technical studies are to refine the project definition and substantiate cost feasibility. The recommended studies are: 1) evaluating maximum MSD WWTP flows and minimum discharges; 2) acquiring customer commitments and acceptable terms; and 3) conducting a hydrogeological investigation of the Montecito Groundwater Basin to determine the technical feasibility of groundwater augmentation.

Implementation Schedule for Recommended Project

Task	2019				2020				2021			
	Q1	Q2	Q3	Q4	Q1	Q2	Q3	Q4	Q1	Q2	Q3	Q4
Technical Studies	█											
Facilities (WRF and Distribution)												
Preliminary Design			█									
Final Design					█							
CEQA		█										
Funding / Financing	█											
Bid/Award									█			
Construction (WRF and Distribution)										█		

Future Phases

In parallel with Recommended Project activities, MWD should conduct a hydrogeological evaluation of the Montecito Basin to determine capacity to store water, ability to meet minimum travel time, and determine locations of private wells. This effort will support a decision whether to proceed with groundwater augmentation in the future.

Conclusion

Given the long-term risks and decreased reliability associated with the State Water Project and local surface water supplies, the Montecito Water District is committed to pursuing local, drought proof supplies. The District is committed to achieving 85% local, reliable drought proof supplies by 2025, including District groundwater, Doulton tunnel infiltration, locally or regionally imported/purchased water, local or regional banked water, and recycled water (2015 UWMP). The District is currently implementing or is in the process of developing long-term programs and/or projects to meet future water supply needs, including this plan to evaluate recycled water options.

This plan recommends implementation of a recycled water project (Alternative B; NPR MSD3) for irrigation of local golf courses, cemetery, and other landscapes that are likely to remain in place for the foreseeable future. Thus, using a non-potable water, in this case recycled water, to meet non-potable demands avoids using high quality potable water for irrigation. The recommended project maintains the option for MWD to pursue groundwater augmentation or direct potable reuse in the future if future evaluations demonstrate their feasibility and cost effectiveness such that investments in the recommended non-potable reuse project would not be stranded assets.

This plan also recommends partnering with the Carpinteria Valley Water District on their IPR project in the Carpinteria Groundwater Basin in parallel with the recommended project within MWD’s service area. The partnership will require many details to be worked through – particularly the water exchange conditions.

MWD Board can now take the evaluation and findings from this study and consider whether to move forward with recycled water in parallel with or in place of other potential water supply opportunities.

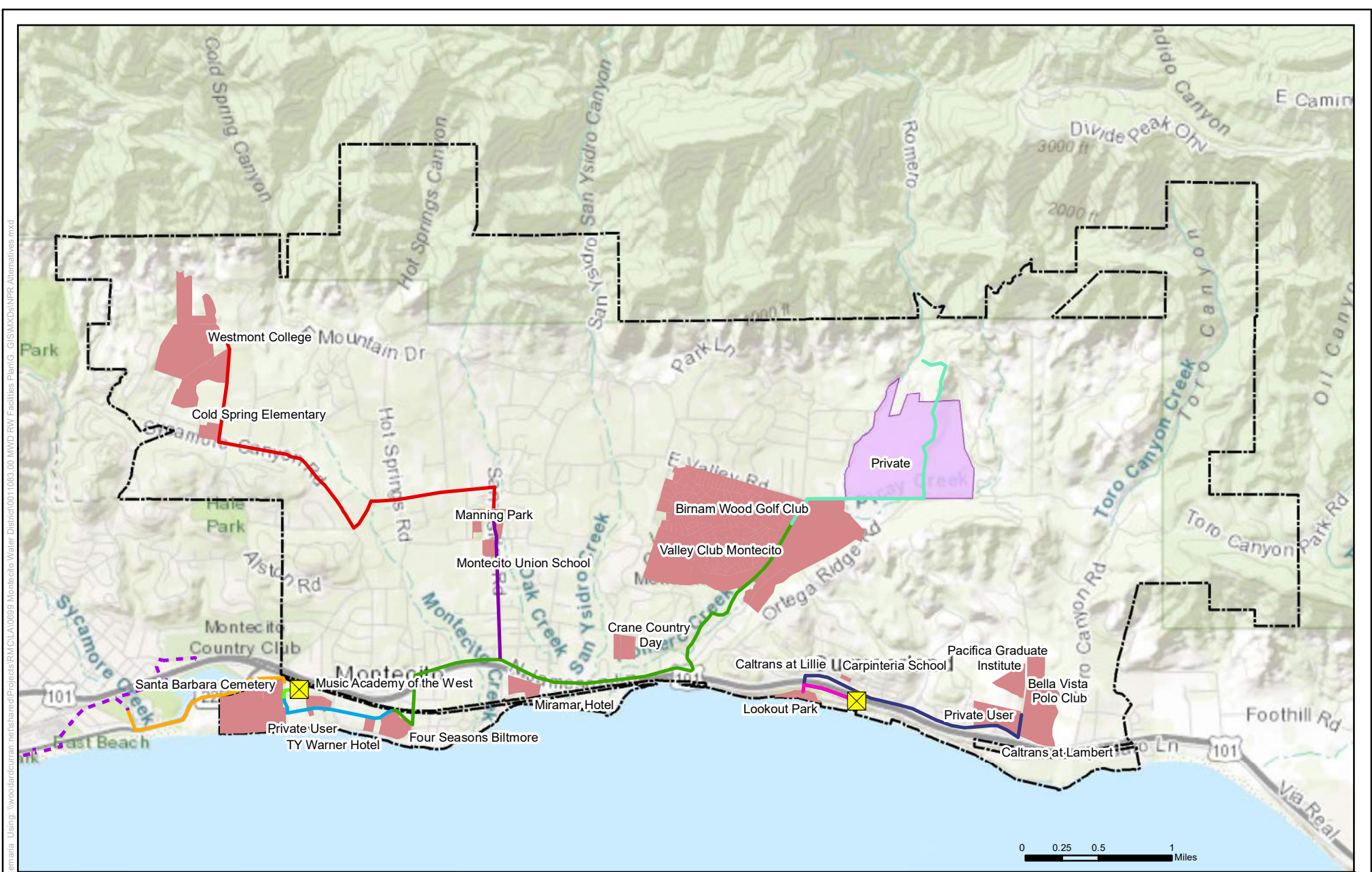

Figure Exported: 10/31/2018 By: mdemania Using: \\woodardcurran.net\shared\Projects\RM\CL\A\0699\Montecito Water District\0011083_00 MWD RW Facilities Plan\G_GIS\MXDs\NPR Alternatives.mxd

MWD Recycled Water Facilities Plan
Figure ES-1
Non Potable Reuse Alternatives

Legend	
	NPR MSD1 & SB1
	NPR MSD2 & SB2
	NPR MSD3 & SB3
	NPR MSD3a
	NPR MSD3b
	NPR MSD3c
	NPR SSD1
	NPR SSD2
	NPR SB1 & SB2 & SB3
	Landscape Irrigation Use
	Agricultural Irrigation Use
	WWTP
	City of Santa Barbara Recycled Water
	Montecito Water District





Project #: 0011083
 Map Created: November 2018

Third Party GIS Disclaimer: This map is for reference and graphical purposes only and should not be relied upon by third parties for any legal decisions. Any reliance upon the map or data contained herein shall be at the users' sole risk. **Data Sources:**

ADMIN DRAFT

Figure ES-2: MWD Recycled Water Facilities Plan. GISMXS\IPR Alternatives.mxd

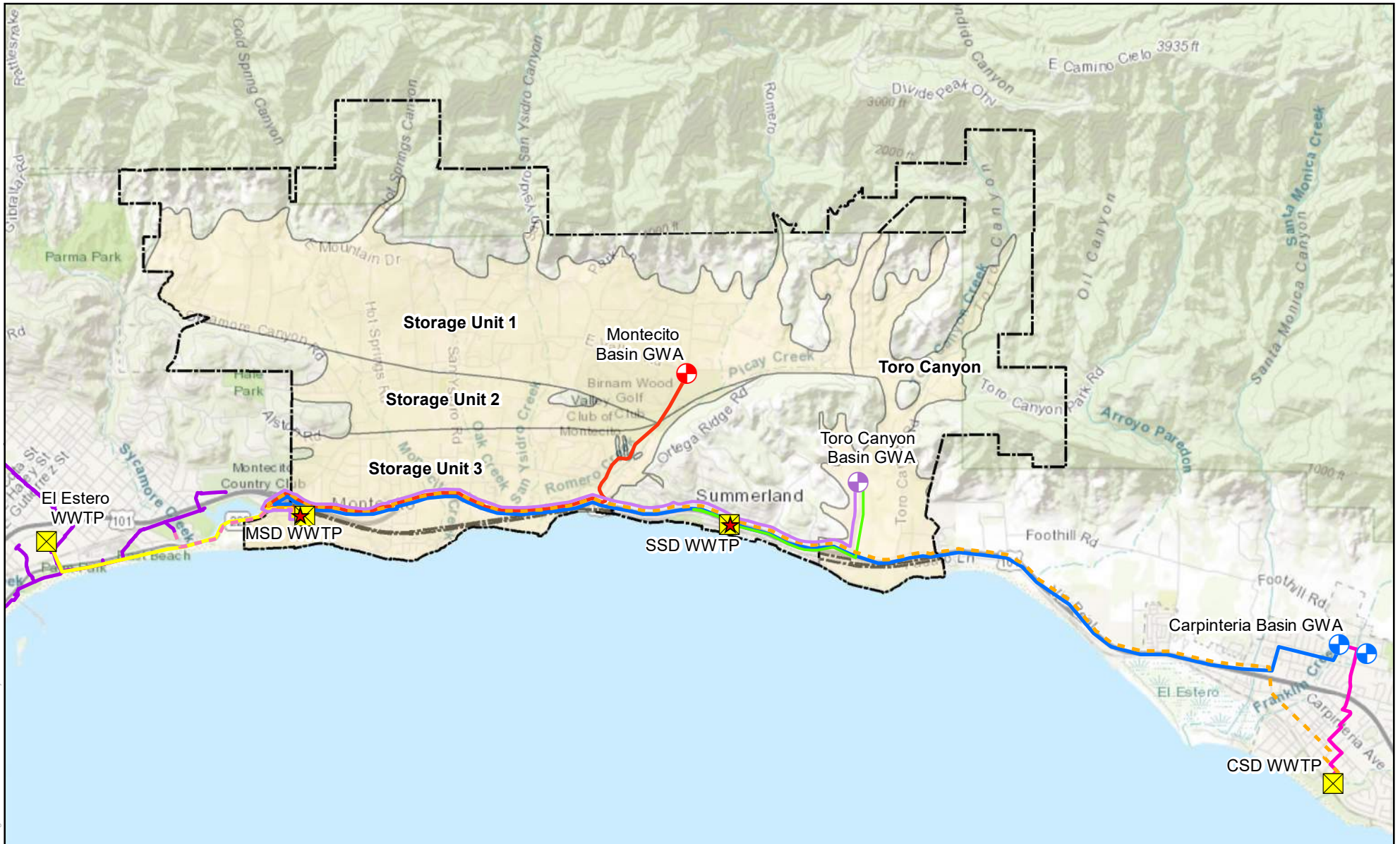

MWD Recycled Water Facilities Plan
Figure ES-2
Indirect Potable Reuse Alternatives

Legend

- ★ Proposed AWTF
- ☒ WWTP
- ⊕ Montecito Basin GWA
- ⊖ Toro Canyon Basin GWA
- ⊕ Carpinteria Basin GWA
- ↗ IPR MSD1 & SB1
- ↘ IPR SB1a
- ↙ IPR SB1b
- ↖ IPR MSD2
- ↗ IPR MSD3a
- ↘ IPR MSD3b
- ↙ IPR SSD2
- ↖ IPR 4
- City of Santa Barbara Recycled Water
- Groundwater Storage Units
- Montecito Water District

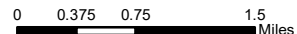

Project #: 0011083
 Map Created: November 2018

Third Party GIS Disclaimer: This map is for reference and graphical purposes only and should not be relied upon by third parties for any legal decisions. Any reliance upon the map or data contained herein shall be at the users' sole risk. **Data Sources:**

ADMIN DRAFT

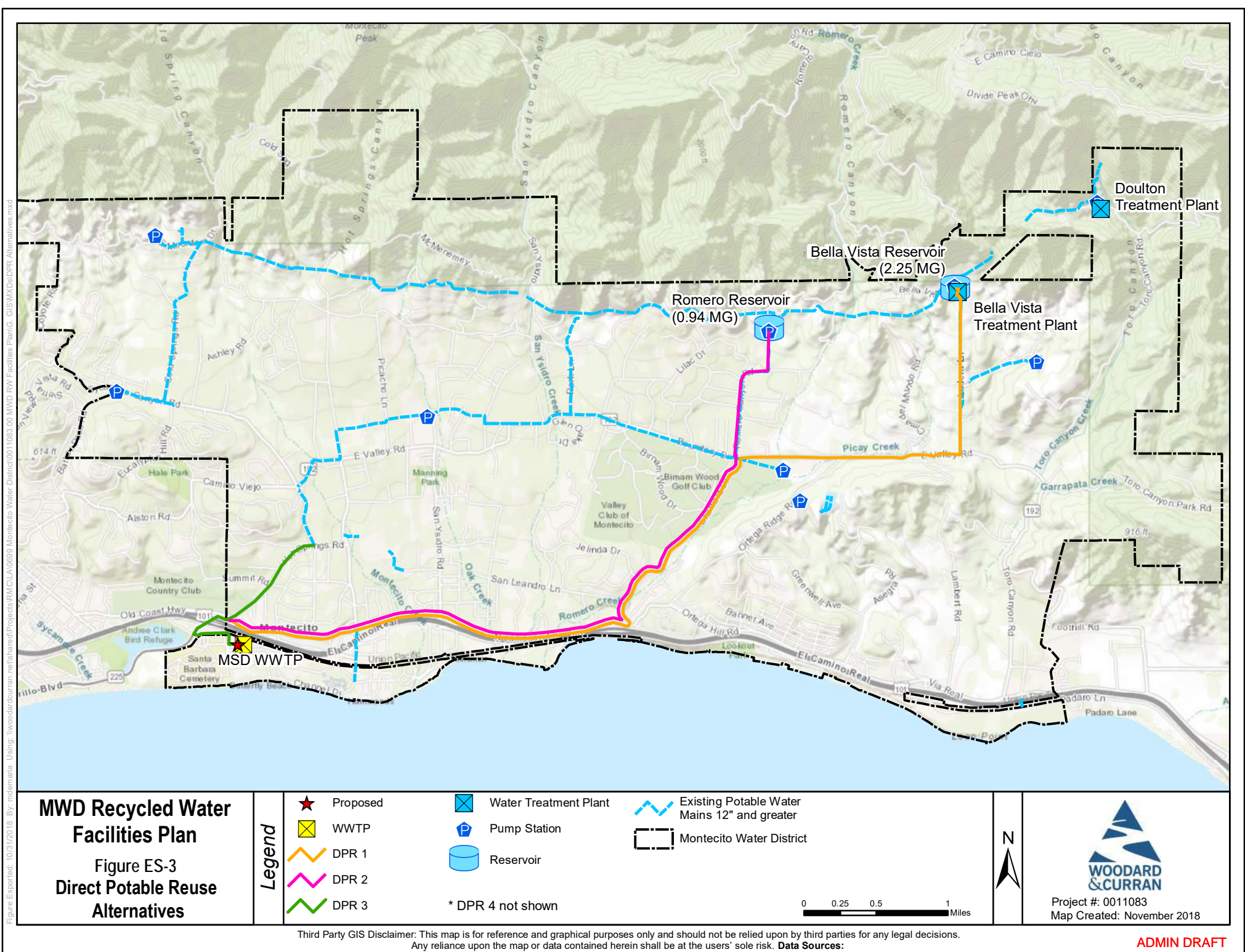
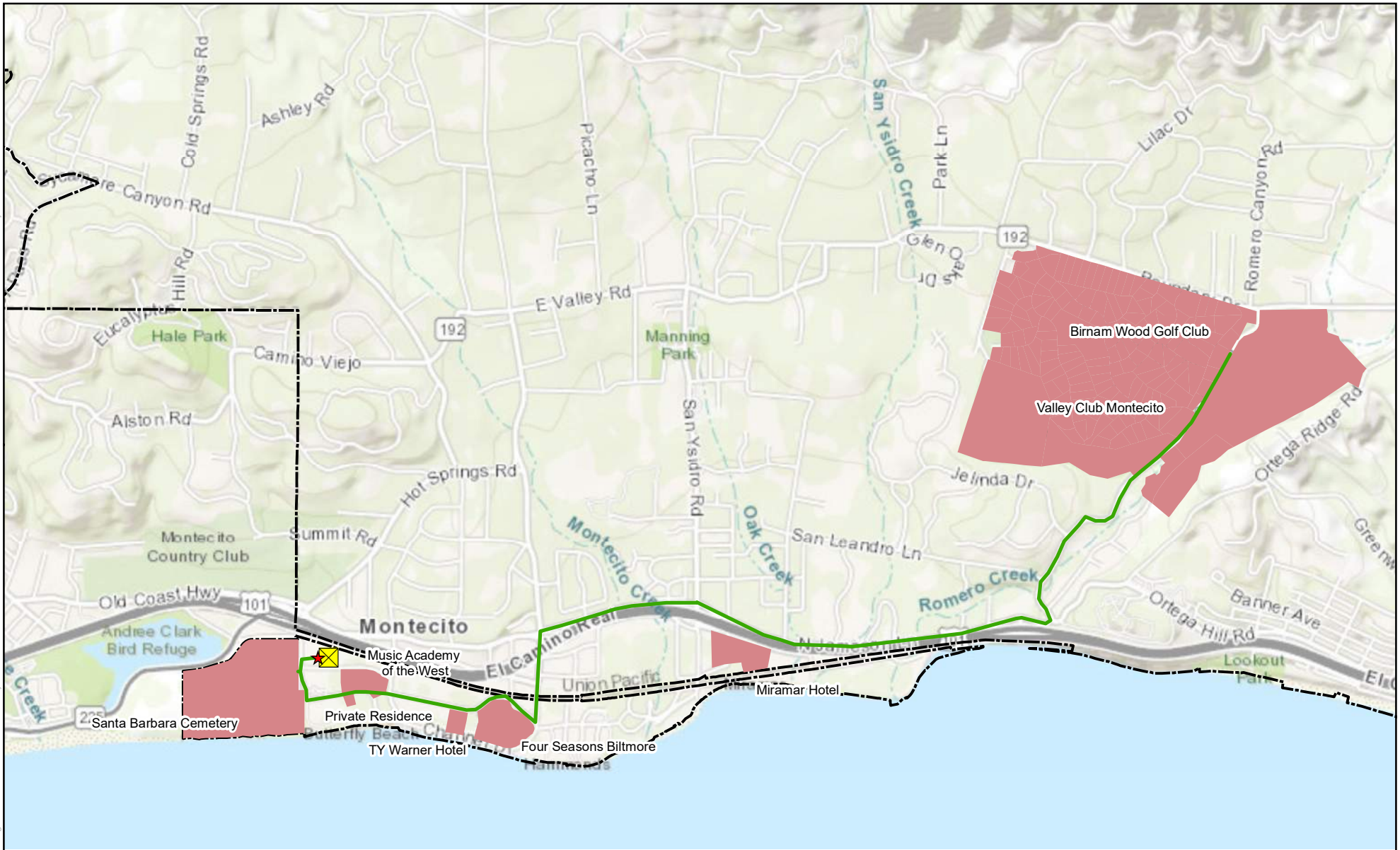

Figure ES-3: MWD Recycled Water Facilities Plan. Montecito Water District. 0011083.00 MWD RW Facilities Plan. G:\GIS\MapDocs\PR Alternatives.mxd

Third Party GIS Disclaimer: This map is for reference and graphical purposes only and should not be relied upon by third parties for any legal decisions. Any reliance upon the map or data contained herein shall be at the users' sole risk. **Data Sources:**

Figure ES-4
Recommended Project



Note: The pipeline alignment shown is preliminary and will be evaluated during future design phases.

MWD Recycled Water Facilities Plan

Figure ES-4
Recommended Project

Legend

- ★ Proposed AWTF
- ✘ Montecito WWTP
- 🟩 NPR MSD3
- 🟥 Landscape Irrigation Customers
- ⬜ Montecito Water District

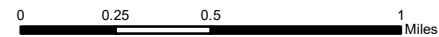

Project #: 0011083
Map Created: November 2018

Third Party GIS Disclaimer: This map is for reference and graphical purposes only and should not be relied upon by third parties for any legal decisions. Any reliance upon the map or data contained herein shall be at the users' sole risk. **Data Sources:**

ADMIN DRAFT

1. INTRODUCTION

1.1 Report Background

Given the long-term risks and decreased reliability associated with the State Water Project (SWP) and local surface water supplies, the Montecito Water District (MWD or District) is committed to pursuing local, drought proof supplies. The District is committed to achieving 85% local, reliable drought proof supplies by 2025, including District groundwater, Doulton Tunnel infiltration, locally or regionally imported/purchased water, local or regional banked water, and recycled water. The District is currently implementing or is in the process of developing long-term programs and/or projects to meet future water supply needs. These programs and projects include:

- Demand Reduction/Conservation Program: In accordance with the California Urban Water Conservation Council's (now known as California Water Efficiency Partnership) best management practices
- Groundwater Management: In accordance with the 2014 Sustainable Groundwater Management Act
- Groundwater Banking: Local and statewide groundwater banking programs to bank water during wet years to meet dry year demands and increase water supply reliability
- Desalination: Long-term water supply agreement for imported/purchased water from the City of Santa Barbara resulting from the Charles E. Meyer Desalination Plant.
- Recycled Water: Non-potable and/or potable reuse of local wastewater that is currently discharged to the ocean.

The District's 2015 Urban Water Management Plan Update (2105 UWMP), completed in May 2017, estimates 200 AFY of recycled water could be delivered to District customers by 2020 and a total of 1,000 AFY in deliveries by 2025. The purpose of this report is to investigate feasible recycled water projects. Depending on the results of the Study, the quantities and timing of deliveries may change.

1.2 Report Objectives

The purpose of the study is to define near-term and long-term recycled water alternatives for comparison with other alternative water supplies. The objectives of this report include:

- Define recycled water alternatives 'world of possibilities'
- Provide initial screening based on cost to identify the top alternatives to carry forward
- Evaluate the top alternatives based on quantitative and qualitative criteria
- Select a preferred recycled water project or group of projects
- Define an implementation plan for the recommended project(s)

Recycled water can provide a locally controlled, drought resistant, and environmentally friendly water supply to incorporate into the District's overall water supply portfolio. The report considers both non-potable reuse (irrigation) and potable reuse option(s). Three sources of recycled water supply are considered: Montecito WWTP, City of Santa Barbara Wastewater's El Estero Treatment Plant (WWTP), and Summerland WWTP. In addition, regional projects with City of Santa Barbara and Carpinteria Valley Water District are considered where the District would be a partner in a larger recycled water project outside the District's service area and the District would receive water via an "exchange" from Lake Cachuma/South Coast Conduit.

1.3 Planning Documents

The following planning documents were referenced in this report (listed in reverse chronological order)

- 2015 Urban Water Management Plan Update (MWD, May 2017):
- Status Update on Recycled Water Issues Memo (MWD, November 12, 2015)
- Montecito Groundwater Basin Recharge Feasibility Study (Dudek, September 2015)
- Potential Recycled Water Opportunities – Wastewater Quality Report (MWD, August 19, 2014)
- Water Supply Reliability – Overview of Potential Recycled Water Opportunities (MWD, July 15, 2014)
- South Coast Recycled Water Development Plan (RMC, December 2013)
- Montecito Water Reclamation Study (CH2M HILL, January 1991)

2. PLAN SETTING

This section provides a characterization of the study area, water supply and use, and wastewater treatment and disposal.

2.1 Study Area Characteristics

The study area consists of District's service area and neighboring water agencies (Figure 1). The District's service area encompasses the boundaries of the local wastewater agencies: Montecito Sanitary District (MSD) and Summerland Sanitary District (SSD). The adjacent water agencies, the City of Santa Barbara (City or SB) and Carpinteria Valley Water District (CVWD), are included for opportunities for regional recycled water projects. Also, the City's WWTP is a potential recycled water supply for use within the District.

MWD was formed as a County Water District in November 1921, in accordance with the California Water Code, with the purpose of furnishing potable water within Montecito. MWD is bounded on the north by the Santa Ynez Mountains, the east by the CVWD, the west by the City of Santa Barbara, and south by the Pacific Ocean. MWD's service area currently includes the unincorporated Montecito and Summerland communities, as well as Toro Canyon, portions of the western Carpinteria Valley, and an eastern portion of the City of Santa Barbara. MWD's service area currently covers 9,909 acres and provides water service to a population of approximately 11,400 (2015 UWMP).

2.1.1 Land Use

Land use in MWD's service area is shown in Figure 2. The area is primarily residential with generally large (one or more acres) sized parcels. Citrus and avocado orchards compose the majority of the estimated 807 acres (8% of the total service area) devoted to agriculture (2015 UWMP). The remainder of the community is urbanized or characterized by tracts of undeveloped natural hillsides and lowlands vegetated with native brush. Most development has occurred within the narrow coastal plains and foothills. Future development in the community is regulated by the Santa Barbara County Department of Planning and Development.

2.1.2 Hydrologic Features

MWD's service area is contained within the Santa Barbara Coastal Watershed and includes five subwatersheds: San Ysidro Canyon, Romero Canyon, Toro Canyon, Carpinteria Creek, and Sycamore Canyon. Surface drainage occurs via several small creeks that flow from the Santa Ynez Mountains south to the Pacific Ocean: Cold Springs Creek, Hot Springs Creek, San Ysidro Creek and Romero Creek. Average precipitation within the study area ranges from about 18 inches per year near the coast to about 25 inches per year in the foothills of the Santa Ynez Mountains.

2.1.3 Groundwater Basins

The study area overlies the Montecito Groundwater Basin (Basin) and a portion of the Carpinteria Groundwater Basin (Figure 3). The Basin encompasses about 9.8 square miles between the Santa Ynez Mountains and the Pacific Ocean. It is separated from the Carpinteria Groundwater Basin to the east by faults and bedrock and from the Santa Barbara Groundwater Basin to the west by a topographical divide and to the south by the Montecito Fault. The Basin has been divided into three storage units based on east-west trending faults that act as barriers to groundwater movement. The northern unit (Storage Unit 1) is bounded on the south by the Arroyo Parida fault, the central unit (Storage Unit 2) by the Montecito Fault, the southern unit (Storage Unit 3) by the Rincon Creek Fault (County 2011, DWR 1999). Also, the Toro Canyon Storage Area (also referred to as Storage Unit 4) is a sub-basin of the western edge of the Carpinteria Groundwater Basin that is located within MWD service area. An administrative boundary on the west separates the Basin from the Santa Barbara Groundwater Basin. The major water bearing geologic formations of the Basin include the Casitas Formation and older alluvium.

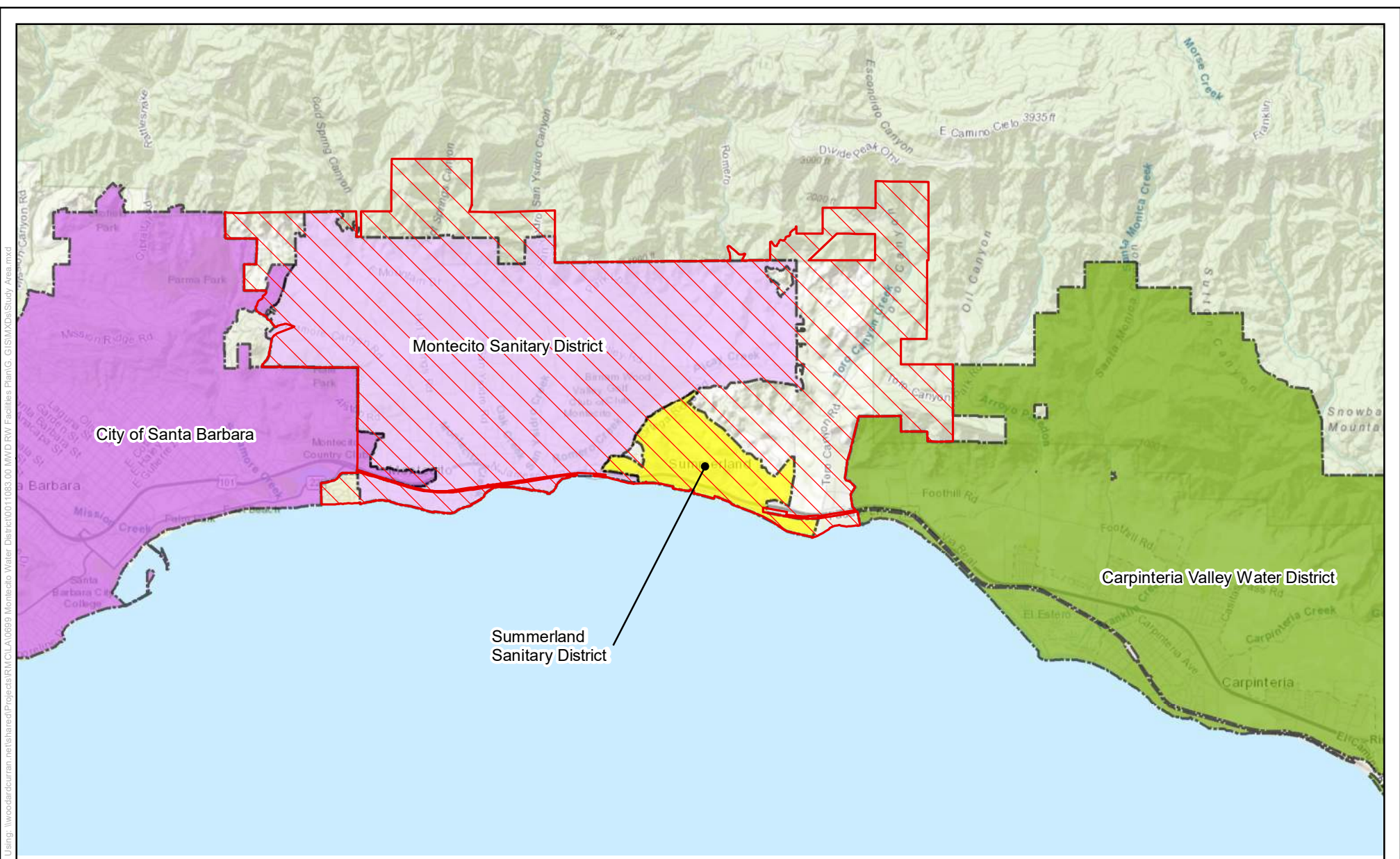

Figure Exported: 10/31/2018 By: mdemania Using: \\woodardcurran.net\shared\Projects\RM\CLAU0695\Montecito Water District\0011083_00 MWD RW Facilities Plan\G. GIS\MXD\Study Area.mxd

MWD Recycled Water Facilities Plan

Figure 1 Study Area

Legend

-  Montecito Water District
-  Montecito Sanitary District
-  Summerland Sanitary District
-  City of Santa Barbara
-  Carpinteria Valley Water District

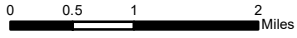

Project #: 0011083
Map Created: November 2018

Third Party GIS Disclaimer: This map is for reference and graphical purposes only and should not be relied upon by third parties for any legal decisions. Any reliance upon the map or data contained herein shall be at the users' sole risk. **Data Sources:**

ADMIN DRAFT

Figure Exported: 11/17/2018 By: mde maria Using: \\woodardcurran\ne\shared\Project\RM\CL\A0659-Montecito Water District\0011083-00-MWD RW Facilities Plan\G...GIS\AXD\SLand Use.mxd

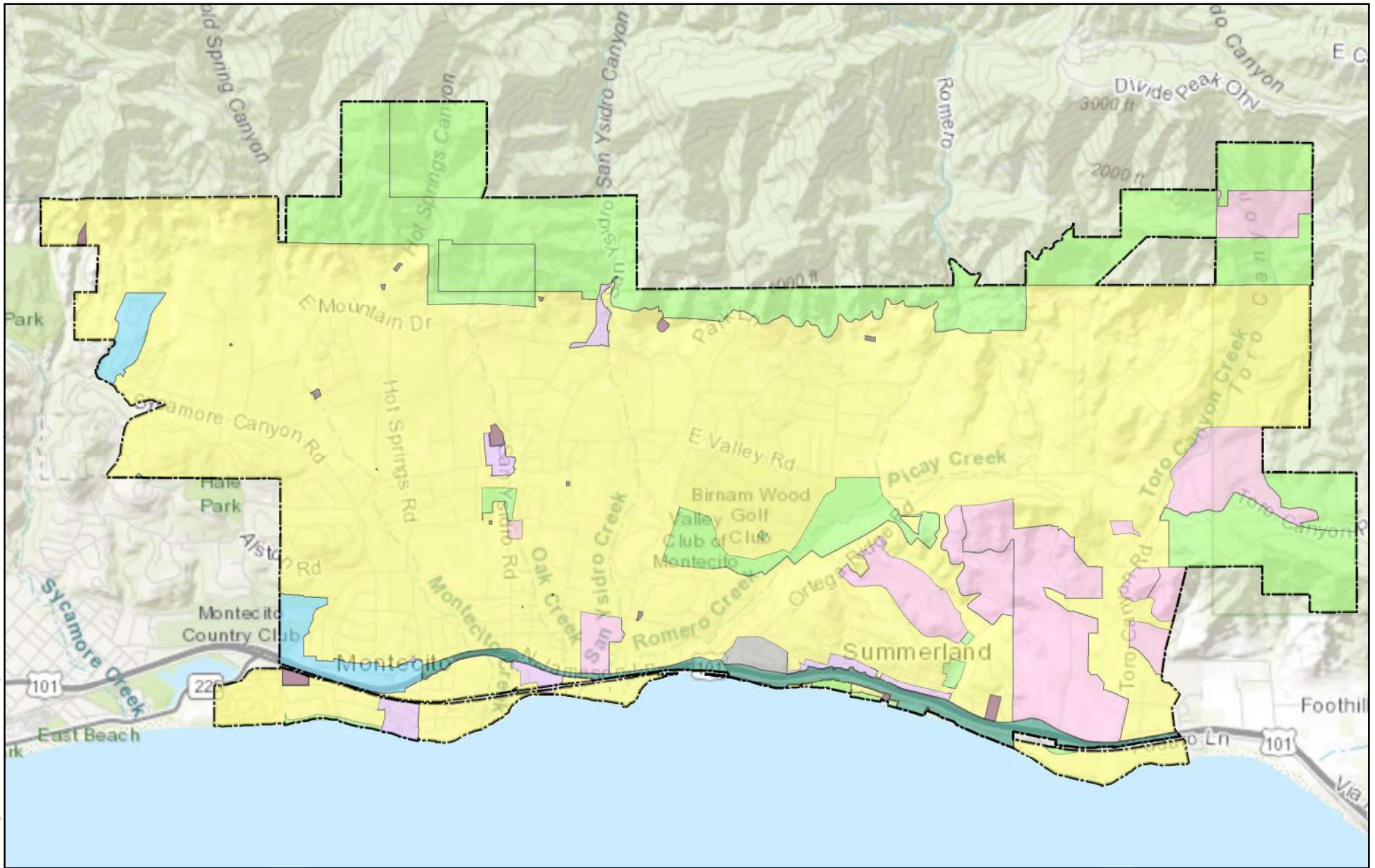

MWD Recycled Water Facilities Plan

Figure 2 Land Use

Legend

- | | | | |
|-------------|-----------------|-------------------------|--------------------------|
| Agriculture | Institutional | Residential | Montecito Water District |
| Commercial | Open Space | Transportation Corridor | |
| Industrial | No Jurisdiction | Utility | |

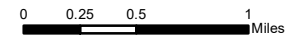

Project #: 0011083
Map Created: November 2018

Third Party GIS Disclaimer: This map is for reference and graphical purposes only and should not be relied upon by third parties for any legal decisions. Any reliance upon the map or data contained herein shall be at the users' sole risk. **Data Sources:**

ADMIN DRAFT

Figure Exported: 11/17/2018 By: mde maria Using: \\woodardcurran\ne\shared\Projects\RM\CL\A\0659_Montecito Water District\0011083\00_MWD RW Facilities Plan\GIS\MapDocs\Groundwater Basin.mxd

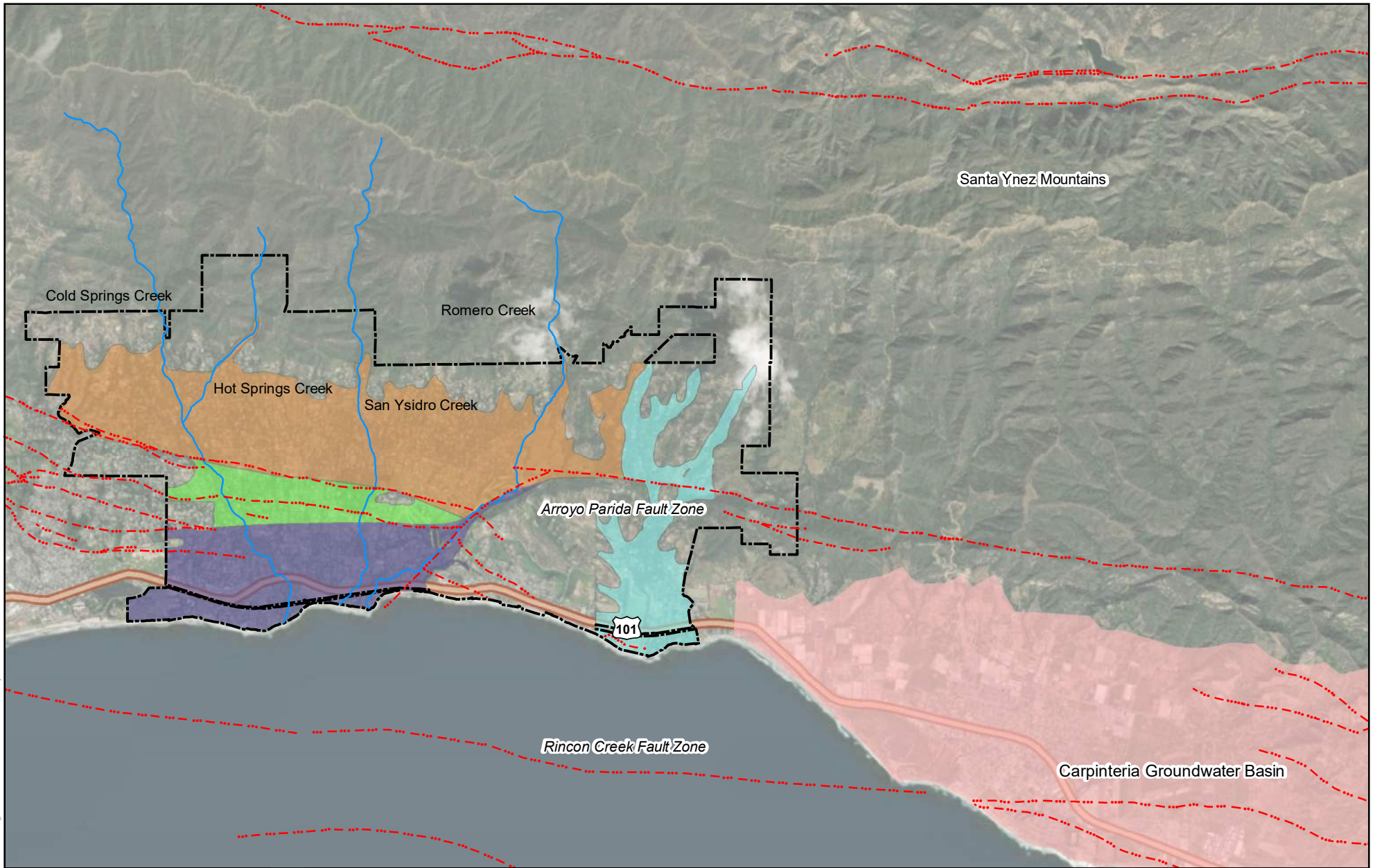

MWD Recycled Water Facilities Plan
Figure 3
Study Area Groundwater

Legend	Storage Unit #1	Carpinteria Groundwater Basin
	Storage Unit #2	Montecito Water District
	Storage Unit #3	Quaternary Faults
	Toro Canyon Storage Unit	

0 0.5 1 2 Miles

Project #: 0011083
Map Created: November 2018

Third Party GIS Disclaimer: This map is for reference and graphical purposes only and should not be relied upon by third parties for any legal decisions. Any reliance upon the map or data contained herein shall be at the users' sole risk. **Data Sources:**

Natural recharge in the Basin is derived from infiltration of precipitation over the basin, seepage from streams, and subsurface inflow from consolidated rocks (DWR 1999). Due to the hydrogeology of the District's groundwater basins, District historical observations indicate that there are only a few areas where stormwater augmentation may impact the recharge of very shallow low production non-potable wells (2015 UWMP). The maximum usable groundwater storage for the four storage units is estimated to be 16,110 AF and maximum safe yield of 1,650 AFY (2015 UWMP). Table 1 identifies the safe yield for each storage unit.

Table 1: Montecito Basin Annual Safe Yield by Storage Unit

Storage Unit	Safe Yield (AFY)
Storage Unit 1	550
Storage Unit 2	100
Storage Unit 3	700
Toro Canyon Storage Unit	300
Total	1,650

Source: Safe Yield Evaluation of the Montecito Basin and Toro Canyon Area (Hoover 1980)

MWD currently operates six potable and six non-potable wells in three of the four storage units. The potable wells all withdraw groundwater from Storage Unit 3 while five of the six non-potable wells withdraw groundwater from Storage Unit 1. There is one non-potable well located in the Toro Canyon Storage Unit.

Historical groundwater production typically ranges between 100 to 450 AFY under normal hydrologic conditions with an increase in production during drought conditions in accordance with MWD's conjunctive use programs. However, the amount pumped by private well owners is unknown. Recent groundwater production by MWD wells is summarized in Table 2.

Table 2: Summary of Recent Groundwater Pumping, AFY

Sub-basin	Quality	2011	2012	2013	2014	2015	2016	2017
Storage Unit 1	Non-potable & Potable	114	129	111	68	59	43	154
Storage Unit 3	Potable	10	135	314	497	528	430	367
Toro Canyon Storage Unit	Potable	0	15	35	42	50	57	62
Total		124	279	460	607	637	530	583

Source: MWD 2015 UWMP and MWD data

2.1.3.1 Sustainable Groundwater Management Act

The California Department of Water Resources (DWR) and the Sustainable Groundwater Management Act (SGMA) identifies groundwater basins and sub-basins in conditions of critical overdraft. Conditions of critical overdraft result from undesirable impacts which can include seawater intrusion, land subsidence, groundwater depletion, and/or chronic lowering of groundwater levels. As defined in the SGMA, "A basin is subject to critical overdraft when continuation of present water management practices would probably result in significant adverse overdraft-related environmental, social, or economic impacts." Basins believed to be critically over drafted were identified in Bulletin-118, 1980 and was updated in 2003 to include the same areas with the revised basin boundaries. Based on MWD's water level monitoring program and State Bulletin 118, the basins are not considered to be in critical overdraft condition but groundwater levels are currently below historical levels.

The Montecito Groundwater Basin is not an adjudicated groundwater basin and was recently classified as a medium priority groundwater basin under SGMA. MWD intends to work towards being the designated Groundwater

Sustainability Agency for the Montecito Basin and to develop the needed basin governance and Groundwater Sustainability Plan. MWD plans to prepare a Groundwater Sustainability Plan that is compliant with SGMA.

2.1.4 Population Projections

The community of Montecito is an unincorporated census designated place (CDP) in Santa Barbara County. As a CDP, the community of Montecito population is published within the census; however, MWD boundaries do not align with the CDP. An evaluation of the MWD boundary from the 2015 UWMP indicates that it encompasses all of the Montecito CDP and Summerland CDP, a portion of the Toro Canyon CDP and small areas of the City of Santa Barbara. Future population estimates were developed based upon population projections from the Santa Barbara County Association of Governments (SBCAG) data as adopted in the 2040 Regional Transportation Plan and Sustainable Communities Strategy. Population estimates were based on a straight line interpolation from the SBCAG data from 2010 through 2035. If zoning changes occur to allow subdividing parcels or the addition of accessory dwelling units, the population may increase.

Table 3: Historic and Projected Population

2010	2015	2020	2025	2030	2035
11,309	11,375	11,441	11,506	11,572	11,638

Source: MWD 2015 UWMP

Note:

1. 2010 and 2035 values from population projections by SBCAG as adopted in the 2040 Regional Transportation Plan and Sustainable Communities Strategy. Interim years are a straight line interpolation from 2010 to 2035.
2. Population estimate does not include seasonal residents, such as students and residents of second homes.

2.2 Water Supply Characteristics and Facilities

This section presents the various sources of water supply and the facilities owned or operated by MWD to obtain, treat, and distribute those supplies.

2.2.1 Water Supplies

MWD has a diverse variety of local, regional, and State water supply sources and continues to align with other water purveyors in the area to identify, investigate, and implement new local and drought proof sources. As shown in Figure 4, MWD currently receives water from the following sources:

- State Water Project (SWP) / Central Coast Water Authority (CCWA) – State Surface Water
- Supplemental Water Purchases
- Cachuma Lake / Cachuma Project – Regional Surface Water
- Jameson Lake – Surface Water from the Santa Ynez River
- Doulton Tunnel Infiltration – Local Groundwater
- Groundwater Wells – Local Groundwater

MWD is one of many public water agencies in Santa Barbara County. Not all properties within MWD’s service area are served by MWD. Those properties not served by MWD are provided water by private groundwater wells operated individually or by private water companies. The use and treatment of water from groundwater wells for potable use by individual private water well operators is under the permit authority of Santa Barbara County.

Figure 4: Montecito Water District Water Supplies



Source: Montecito Water District

2.2.1.1 State Water Project (SWP)

MWD purchases SWP water as a member of the CCWA, which is a Joint Powers Authority formed to construct, manage, operate, and maintain the SWP coastal aqueduct treatment and conveyance facilities serving Santa Barbara County. Purchased SWP water is used to augment traditional water supplies available to MWD, reduce the use of groundwater, and offset naturally occurring reservoir siltation at Cachuma and Jameson reservoirs.

MWD participates in the CCWA by storing a portion of its annual 3,300 AF allocation in a “drought buffer” in the amount of 300 AF. The 300 AF drought buffer represents water for which there is no design capacity in the coastal branch facilities, but which is available for delivery in any year in which the DWR delivery allocation percentage is less than 100% (2015 UWMP).

MWD stores its SWP water in San Luis Reservoir, a SWP facility before it is conveyed to Lake Cachuma. If San Luis Reservoir is at full capacity and is spilling, MWD’s stored water is at risk of being lost. To mitigate this potential risk, MWD, along with the other Santa Barbara County water agencies, consider groundwater banking opportunities annually through CCWA to place water into various regional groundwater banking programs around the State. The water storage banking programs are typically operated as unbalanced exchanges, where more water is stored than can be delivered (or returned) at a later date. Since 2014, MWD has recovered and delivered nearly 1,000 AF of banked water from various groundwater banking programs including the Dudley Ridge Water District, which is water stored outside of Santa Barbara County.

In April 2017, the MWD entered into a long-term groundwater water banking arrangement with the Semitropic Water Storage District for banking surplus SWP and/or supplemental water in the Semitropic Groundwater Banking and Exchange Program. Participation in the program involved purchasing the rights to store up to 4,500 AF of water and guaranteeing the return of up to 1,500 AF per year of water stored in the program. This program provides a permanent and regionally located groundwater basin to store excess water during periods of normal or above normal rainfall for future use during periods of drought. As of the end of October 2018, the District has 900 AF of water stored in a groundwater basin with the Semitropic Water Storage District. Participation in this program bolsters future SWP deliveries if or when future SWP allocations are reduced whereby improving the reliability of the SWP.

2.2.1.2 Supplemental Water Purchases

Due to the variability in the amount of SWP water available under various hydrologic conditions, MWD relies upon the SWP infrastructure to provide MWD with the ability to augment its supplies with supplemental water purchases during dry years. MWD has participated in supplemental water purchase programs negotiated between CCWA and other SWP contractors to increase the available water supply when annual DWR allocations are not sufficient. Supplemental water purchase agreements typically require an exchange component whereby MWD is required to return an amount equal to or a portion of the amount of water purchased. This water return is often referred to as “water debt”. The supplemental water purchase agreements include the return conditions of this water debt which dictate the return period and other conditions that must be met. As of the October 2018, MWD’s water debt was 700 AF.

2.2.1.3 Lake Cachuma / Cachuma Project

Lake Cachuma is an open surface water reservoir owned and operated by the United States Bureau of Reclamation (USBR) receiving water from the Santa Ynez River watershed. The USBR, on behalf of the Cachuma Project Member Units, holds the Cachuma Project water rights permit, and the Cachuma Conservation Release Board is the agency responsible for the actions and decisions relative to the terms and conditions of those permits for its member units. The Cachuma Project member units include Montecito Water District, Goleta Water District, City of Santa Barbara, Santa Ynez River Water Conservation District - Improvement District No. 1, and Carpinteria Valley Water District. Water deliveries from Lake Cachuma are made to member units pursuant to a master contract between the USBR and the Santa Barbara County Water Agency. The five water agencies have individual contracts with the County that defines each water agency’s proportionate share of the Lake Cachuma water supply.

MWD’s proportionate share of the Cachuma water supply is 10.3% and MWD’s available supply from Lake Cachuma during years of normal rainfall is 2,651 AFY (100% Cachuma Project allocation). Lake Cachuma is operated based on an operational yield that was developed through experience during long-term droughts and acceptable delivery reductions during such drought periods.

Lake Cachuma had an original capacity of 205,000 AF at an elevation of 750 feet (NGVD 29 Datum). Per a bathymetric survey conducted in 2013, Lake Cachuma’s capacity has been reduced approximately 21,000 AF due to siltation, with a current capacity of 184,121 AF. While the Bradbury Dam is equipped with flash boards that have raised the maximum elevation to 753 feet with a corresponding capacity of 193,305 AF, this additional storage is dedicated to storing water for fish habitat and does not increase the available water storage for water supply purposes.

The Cachuma Project operates under a permit granted by the California State Water Resources Control Board (SWRCB). The current Water Right Order 94-5 continued earlier requirements for water releases to protect downstream interests of the City of Lompoc, Santa Ynez River Water Conservation District - Improvement District No. 1, and riparian groundwater pumpers located along the Santa Ynez River. This order required hearings to address outstanding issues related to potential project impacts on vegetation, fish and downstream users. The hearings and Environmental Impact Report were completed in 2011, however the draft water rights order has not yet been released by the SWRCB.

The USBR and the member units have developed revisions to the project operations since 1993 to improve habitat conditions for steelhead trout while still maintaining water supplies. In 2000, the National Marine Fisheries Service issued a Biological Opinion for USBR's operation and maintenance of Bradbury Dam (the Cachuma Project). The 2000 Biological Opinion addresses the effects of Cachuma Project operations on steelhead and its designated critical habitat in accordance with Section 7 of the Endangered Species Act of 1973. In 2014, the National Marine Fisheries Service and USBR formally initiated reconsultation of the Biological Opinion which may change MWD's allocation from Lake Cachuma.

Water is diverted from Lake Cachuma through the Tecolote Tunnel, which extends approximately 6.4 miles through the Santa Ynez Mountains to the head works of the South Coast Conduit. The South Coast Conduit is a steel pipeline which runs approximately 26.4 miles and includes four regulating reservoirs - Glen Annie Dam and Reservoir (currently not in service), Lauro Dam and Reservoir, Ortega Dam and Reservoir, and Carpinteria Reservoir. Lake Cachuma water supplies delivered via the South Coast Conduit are treated at Goleta Water District's Corona Del Mar WTP and the City of Santa Barbara's Cater WTP. Cater WTP provides the potable water for Santa Barbara, MWD, and CVWD.

2.2.1.4 Jameson Lake

Jameson Lake is an open surface water reservoir owned and operated by MWD. In the 1920's the Juncal Dam site was transferred from the City of Santa Barbara to MWD with the agreement that MWD would transfer 300 AF of water annually to the City in perpetuity. Subsequent agreements implemented between MWD and the City allow for annual adjustments to the 300 AF.

MWD receives water from the upper reaches of the Santa Ynez River, the North Fork stream and the seasonal diversion at Alder Creek with a total watershed of about 19 square miles. The current capacity of the lake, based on a bathymetric survey completed in 2013, is approximately 5,144 AF with a storage elevation of 2,224 feet. Recent bathymetric surveys have indicated that actual storage has been reduced due to siltation behind the dam. As a part of its long-term water supply management and planning, MWD continues to perform periodic silt surveys and other studies on the reservoir and has developed a conjunctive use operational plan for all District supplies that includes an operational annual yield and rule curve based on Jameson Lake reservoir capacity.

The actual annual diversion of water from this water supply is determined prior to the start of the water year which is dependent on lake water storage level and is based on the operation rule curve included in the 2005 Water Supply Optimization Plan. Water delivered from this source is monitored and controlled on a daily basis by MWD and used along with its other water supplies to maintain water storage levels in secondary water storage reservoirs located throughout the service area.

Water from the lake flows by gravity through an 18-inch diameter pipeline along and through the Santa Ynez Mountain range and enters MWD's service area at the end of the 2.2-mile Doulton Tunnel. The water then flows by gravity to the two surface water treatment plants, storage, and distribution to customers.

The Jameson Lake annual diversion maximum, including all Santa Ynez diversions, is 2,000 AF. Water diverted from Jameson Lake over the last ten years has averaged approximately 10 to 30 percent of MWD's yearly production total. The average yearly diversion over the past ten years ranged from approximately 1,900 AFY to a low of 350 AFY. Diversions over the past three years were greatly reduced due to a severe multi-year drought.

2.2.1.5 Doulton Tunnel Infiltration

The Doulton Tunnel infiltration water supply provides approximately 300 to 350 AFY during consecutive years of normal rainfall. Water produced from the tunnel infiltration is commingled with water being conveyed from Jameson Lake. The

Doulton Tunnel infiltration water is considered to be groundwater and not subject to the 2,000 AFY limitation on surface water.

2.2.1.6 Groundwater Wells

MWD currently operates six potable and six non-potable wells in three of the four storage units underlying MWD. The potable wells all withdraw groundwater from Storage Unit 3 of the Montecito Groundwater Basin while five of the six non-potable wells withdraw groundwater from Storage Unit 1. There is one non-potable well located in the Toro Canyon Storage Unit. Historical groundwater production typically ranges between 100 to 450 AFY under normal hydrologic conditions with an increase in production during drought conditions in accordance with MWD’s conjunctive use programs.

2.2.2 Water Supply Facilities

MWD’s water supply facilities are shown in Figure 5. MWD’s potable water treatment and distribution system is comprised of two surface water treatment plants, nine storage reservoirs, approximately 114 miles of pipeline, seven pump stations, six potable water production wells, and six non-potable production wells (MWD, 2017). All MWD potable water is treated to meet all federal and state drinking water standards. Groundwater for potable use is treated at each well site.

The Jameson Lake water supply is treated at MWD’s Bella Vista WTP or Doulton WTP. The Bella Vista WTP has a 2.2 MGD capacity and the Doulton Treatment Plant has a 150,000 gallon per day (gpd) capacity. The Lake Cachuma water supply and SWP water are treated at the Cater WTP, which has a production capacity of 37 MGD and is owned and operated by the City of Santa Barbara. MWD has a 20% interest in the Cater WTP. The treated water is then conveyed to MWD via the South Coast Conduit.

2.2.3 Water Quality

MWD has not identified water quality concerns for its supplies. Generally, water quality of the District’s wells is suitable for potable and irrigation use. Some of the District wells have small amounts of iron and manganese which is treated and removed prior to distribution to District customers. MWD water met all primary and federal water quality standards. Table 4 lists concentrations of constituents relevant to irrigation uses for the District’s water sources.

Table 4: Existing Source Water Quality for Irrigation Constituents

Constituent	Units	Maximum Contaminant Level	Cachuma Lake (includes SWP)	Jameson Lake (includes Doulton Tunnel groundwater)	Groundwater
Boron	µg/L	1,000	Not Available	Non-detect	50
Chloride	mg/L	500	64.7	6	229
Nitrate (as Nitrogen)	mg/L	10	0.19	0.1	2.36
Sodium	mg/L	No Standard	59	26	99
Total Dissolved Solids	mg/L	1,000	590	530	783

Source: MWD 2017 Annual Drinking Water Consumer Confidence Report; Average concentration

Figure Exported: 10/31/2018 By: medemata Using: \\woodardcurran.net\shared\Projects\RM\CL\A\06959 Montecito Water District\0011083_00 MWD RW Facilities Plan\GIS\MapDocs\Potable Water Facilities.mxd

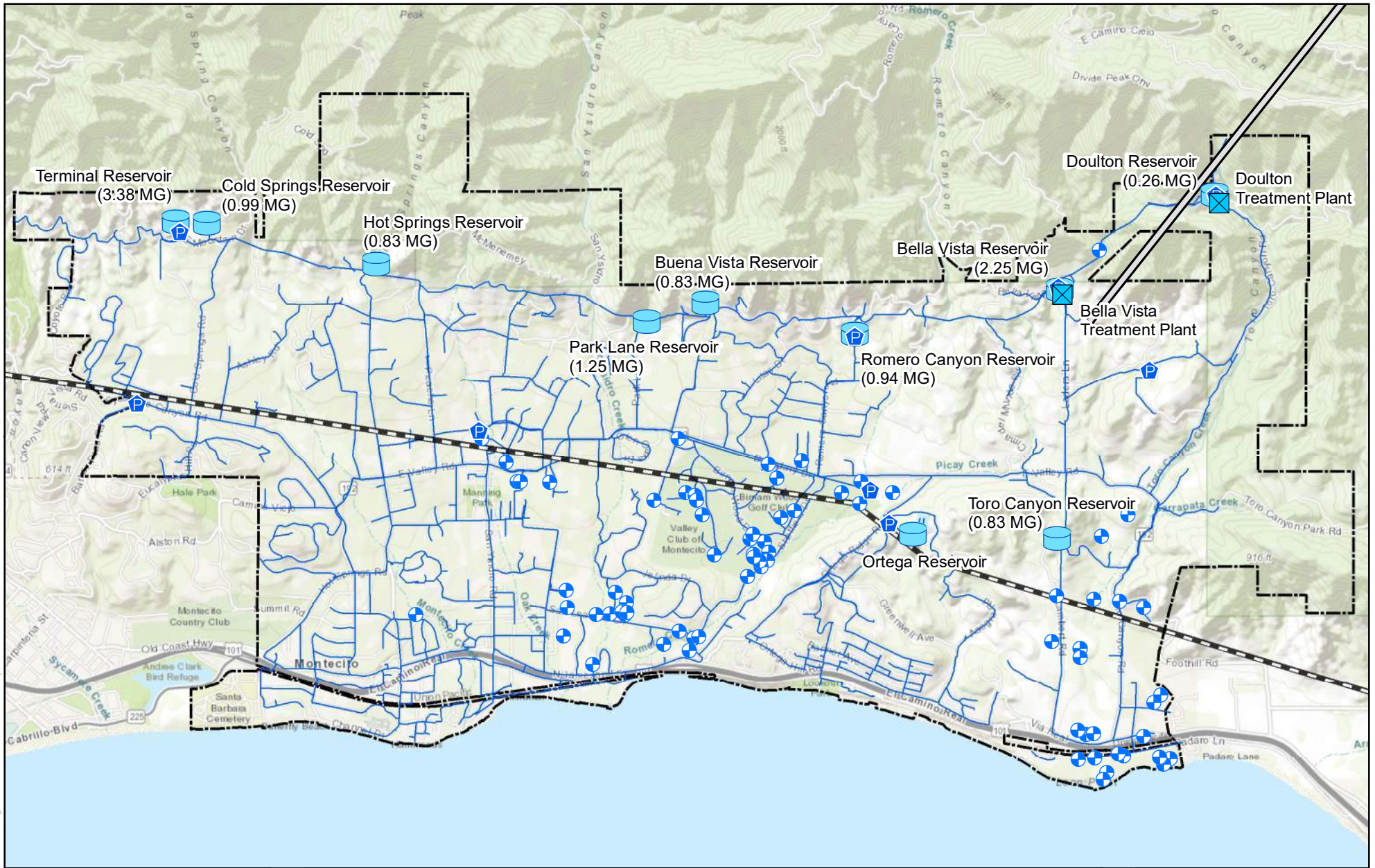

MWD Recycled Water Facilities Plan
Figure 5
MWD Major Water Supply Facilities

Legend

- Water Treatment Plant
- Pump Station
- Reservoirs
- Wells
- Doulton Tunnel
- South Coast Conduit
- Potable Water Mains
- Montecito Water District



Project #: 0011083
 Map Created: November 2018

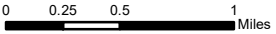

Third Party GIS Disclaimer: This map is for reference and graphical purposes only and should not be relied upon by third parties for any legal decisions. Any reliance upon the map or data contained herein shall be at the users' sole risk. **Data Sources:**

ADMIN DRAFT

2.2.4 Water Demand Projections

This section describes MWD historic, current, and future water use and the methodology used to project future demands within MWD's service boundary. Table 5 summarizes water use for 2011 to 2017. In March 2014, MWD adopted a Water Shortage Emergency Surcharge and instituted monthly customer water use allocations and penalties for water use in excess of allocations, which led to a significant reduction in water use. Despite the repeal of monthly customer water use allocations and penalties in 2017, water use remains about 35% less than predrought usage.

Table 5: Historical Water Use, 2011-2017 (AFY)

2011	2012	2013	2014	2015	2016	2017
4,875	5,710	6,347	3,964	3,517	3,265	3,490

Source: MWD data

Water demand projections (Table 6) are calculated based on future population projections (Table 3) and water use factors. The projections assume that MWD is no longer operating under a water shortage emergency condition with customer monthly allocations but that select water conservation and demand management measures remain in place. An increase in projected water use is anticipated to be associated only with the single family residential classification, with other use classes remaining constant through the planning period.

Table 6: Water Demand Projections (AFY)

Water Use Classification	2020	2025	2030	2035
Single Family Residential	3,046	3,063	3,081	3,098
Multi-Family Residential	81	81	81	81
Commercial	294	294	294	294
Institutional	378	378	378	378
Agricultural	428	428	428	428
Non-Potable	105	105	105	105
Total Meter Water Use	4,331	4,348	4,366	4,383
Non-Revenue	433	435	437	438
MWD Subtotal	4,764	4,783	4,802	4,822
Net Sales, Transfers & Exchanges with Other Agencies	300	300	300	300
Total Water Use	5,064	5,083	5,102	5,122

Source: MWD 2015 UWMP

2.2.5 Water Supply Projections

MWD relies primarily on rainfall dependent surface water supplies, including Lake Cachuma, Jameson Lake, and the SWP. These supplies have historically made up 80% to 90% of its supplies under normal water supply conditions. In addition to the surface water supplies, MWD utilizes local groundwater and Doulton Tunnel intrusion (groundwater). On October 1, 2018, Santa Barbara County began its eighth year of extraordinary drought and the second driest seven-year drought period on record. The County and MWD remain in a declared drought emergency due to the continued reduction in available local and statewide surface water supplies. The rains received locally in 2018 didn't provide the reprieve needed to bring the area out of drought conditions that have plagued it for nearly a decade. Looking forward, MWD is anticipating needing to mitigate lower reliability and lower yield from surface water supply. For example:

- Lake Cachuma reached a historic low of 8% capacity in 2016 and is currently at approximately 30% capacity. Long-term, Cachuma Project allocations are expected to decrease in the future with increased environmental regulations.

- Jameson Lake is at approximately 55% capacity and deliveries are suspended due to water quality challenges resulting from the 2017 Thomas Fire. With the increased likelihood of forest fires impacting the area and associated sedimentation, Jameson Lake deliveries from are expected to decrease over time.
- The SWP averages approximately 60% of full allocation (1,980 AF for MWD) with a 35% allocation in 2018 (1,155 AF). The SWP faces reduced yields and/or higher costs to address climate change and Sacramento-San Joaquin Delta issues.
- Groundwater pumping has increased to 15% (500 AF) of MWD's annual demand in accordance with its conjunctive use program but groundwater levels following the historic drought are at near historic low levels.

When local surface water supplies are limited during periods of drought, MWD must rely more heavily on the SWP facilities for delivery of supplemental water, which is purchased from various SWP contractors across the State. The availability and cost of supplemental water can vary depending on water supply conditions. In recent years, supplemental water purchases have accounted for over half of MWD's available water used annually with annual purchases of up to 5,000 AFY.

Until local water supply conditions improve or the District successfully acquires new local drought proof supplies, such as recycled water, the District will continue to be extremely reliant on a single source of supply, the SWP facilities for a delivery of limited SWP allocation and/or supplemental water deliveries. Consequently, MWD is committed to achieving 85% local, reliable drought proof supplies by 2025 to include locally or regionally imported/purchased water, local or regional banked water, and recycled water.

Customer demands have varied widely over the last decade from as high as nearly 6,300 AFY (in 2013) to 3,300 AFY (in 2016). In 2014, following several years of deepening drought conditions and declining water supplies, MWD adopted water use restriction ordinances establishing customer water use allocations and penalties in an effort to better align customer water use with MWD's available water supplies. This successfully reduced customer water use by nearly 50% from 2013 to 2016. In 2017, recognizing the changes in customer's water use behaviors, MWD transitioned from a mandatory to a voluntary based water use restriction model. To date, customers continue to achieve a 35% to 40% reduction in water use as compared to pre-drought usage.

This commitment to water conservation has helped MWD ensure water availability over its 3-year planning horizon with reliance on supplemental water purchase continues to be reliant on annual supplemental water purchases. In addition, the 2015 UWMP outlined the District's compliance with Senate Bill X7-7, which requires a 20% demand reduction by 2020. Customer demands are currently on track for compliance with this requirement with a target total annual production of 4,400 AFY.

2.2.6 Potable Water Rates

Potable water rates for MWD are summarized in Table 7. The exceptional drought has caused MWD to incur extraordinary costs for the purchase of supplemental water and to adopt a water shortage emergency ordinance leading to a significant reduction in customer water use. The Water Shortage Emergency Surcharge is a temporary measure that is needed to purchase supplemental water, fund drought-related costs, and offset revenue losses. It is added to the water usage rates and applies to all water consumption. The surcharge is adjusted depending on MWD's water sales percentage reduction. The current rate is \$3.45 per hundred cubic feet (HCF) and is added to the current rate as shown in the table below. The factors in setting the surcharge are reevaluated regularly and the charge adjusted to represent actual water reduction and financial conditions. A fixed monthly service charges is also applied based on meter size.

Table 7: Potable Water Rates

Rate Category & Structure	Quantity (HCF)	Current Non-Drought Rate (\$/HCF)	Rate with Water Shortage Emergency Surcharge (\$/HCF)
Single Family			
Tier 1	0-25	\$5.40	\$8.85
Tier 2	26-60	\$5.98	\$9.43
Tier 3	61-120	\$7.06	\$10.51
Tier 4	121>	\$8.50	\$11.95
Multi-Family Per Dwelling Unit			
Tier 1	0-9	\$5.40	\$8.85
Tier 2	10-30	\$5.98	\$9.43
Tier 3	31>	\$7.06	\$10.51
Commercial			
3 YR AVG Month Base Allotment	Each HCF	\$5.98	\$9.43
Over Base Allotment		\$7.06	\$10.51
Institutional			
3 YR AVG Month Base Allotment	Each HCF	\$5.98	\$9.43
Over Base Allotment		\$7.06	\$10.51
Agriculture			
Domestic/DU	20/HCF/DU	\$5.40	\$8.85
Tier 1	<870 HCF/Acre/Year	\$3.00	\$6.45
Tier 2	>870 HCF/Acre/Year	\$5.40	\$8.85

Source: <http://www.montecitowater.com/billing.htm>

Note: The rates were derived from a 5-Year Financial Plan and Cost of Service Study and were adopted in August 2013. Per Board action, the approved 7.4% increase scheduled for fiscal year 2017/18 has not yet been implemented.

2.3 Wastewater Characteristics and Facilities

This section provides an overview of the existing WWTPs and potential recycled water supplies available to the region that are owned and operated by the agencies in the study area.

2.3.1 Existing Facilities

The sources of recycled water in the Study Area are wastewater from the Montecito Sanitary District WWTP (Montecito WWTP), Summerland Sanitary District WWTP (Summerland WWTP), and the City of Santa Barbara's WWTP. In addition, Carpinteria Sanitary District's WWTP is included as part of a regional partnership project. The existing facilities are shown in Figure 6.

Figure Exported: 10/31/2018 By: mdemania Using: \\woodardcurran.net\shared\Projects\RM\CL\A\0695\Montecito\Water District\0011083_00 MWD RW Facilities Plan\GIS\MXDs\Wastewater Facilities.mxd

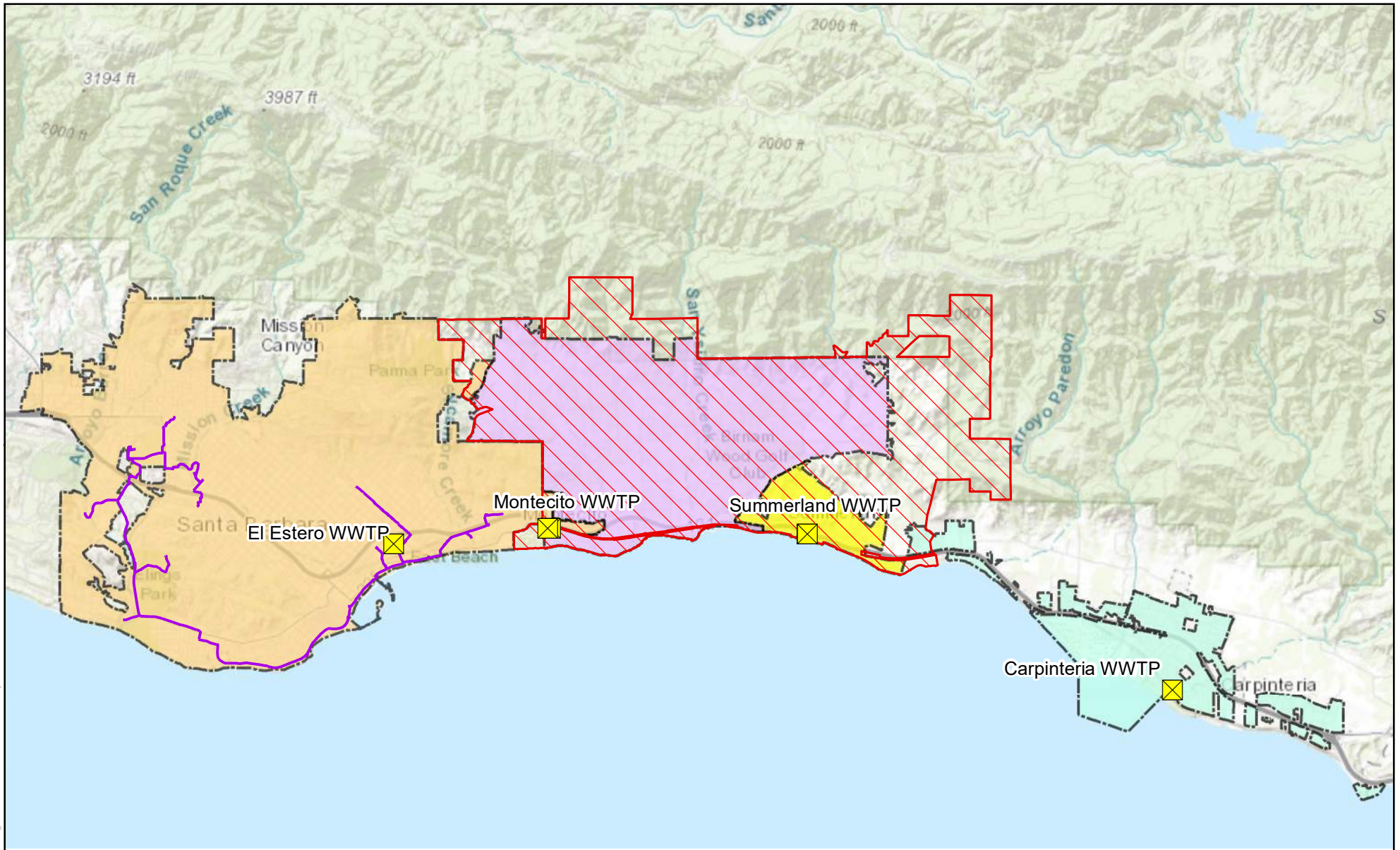

MWD Recycled Water Facilities Plan
Figure 6
Existing Wastewater and Recycled Water Facilities

Legend	WWTP	Summerland Sanitary District
	Existing Recycled Water Mains	Montecito Sanitary District
	Montecito Water District	City of Santa Barbara
	Carpinteria Sanitation District	

0 0.5 1 2 Miles

N

WOODARD & CURRAN

Project #: 0011083
 Map Created: November 2018

Third Party GIS Disclaimer: This map is for reference and graphical purposes only and should not be relied upon by third parties for any legal decisions. Any reliance upon the map or data contained herein shall be at the users' sole risk. **Data Sources:**

ADMIN DRAFT

Table 8 provides a summary of the existing treatment capacities along with average daily flows for each WWTP.

Table 8: Existing Wastewater Treatment Plants Capacity and Flows

Wastewater Treatment Plant	Design Capacity (MGD)	2017 Average Dry Weather Flow (MGD)
Montecito WWTP	1.5	0.59
Summerland WWTP	0.3	0.10
City of Santa Barbara, El Estero WWTP	11.0	5.9
Carpinteria WWTP	2.5	1.1

Source: California Integrated Water Quality System Project (CIWQS); <https://www.waterboards.ca.gov/ciwqs/>

Notes:

1. Average dry weather flow shown in the table is flow from May to September 2017.
2. Montecito WWTP flows have decreased to roughly 0.5 MGD due to business closures and lower residential population following the January 2018 debris flow. Flows are anticipated to return to roughly 0.6 MGD once major hotels re-open and some residents return. However, the timing and amount of future flows is not guaranteed.
3. El Estero WWTP also has 3.0 MGD of treatment capacity to produce disinfected tertiary recycled water.

2.3.2 Montecito WWTP

The Montecito Sanitary District (MSD) is an independent special district voted into existence in 1947, by the residents of Montecito to provide for the collection, treatment and disposal of wastewater. The MSD provides service to approximately 10,000 people through 3,100 service connections. It maintains approximately 78 miles of sewer pipelines and four pumping stations. In 1961, MWD constructed a secondary level wastewater treatment plant, including an ocean outfall (located 1,500 feet offshore) and trunk sewer system. Currently, the plant's capacity is 1.5 MGD and treats approximately 0.50 MGD to secondary treatment level.

The Montecito WWTP consists of macerators, aerated activated sludge tanks, secondary clarification, chlorination, and dechlorination. Waste activated sludge from the activated sludge tanks is sent to a dissolved air flotation tank for thickening. The sludge is pumped from the dissolved air flotation tank to an aerobic digester to a dewatering belt press. The dewatered biosolids are stockpiled in a holding bin, which is then hauled from the site by a composting company. Wastewater is discharged to the Pacific Ocean through a 1,500-foot outfall/diffuser system.

Figure 7: Montecito WWTP Flow Schematic

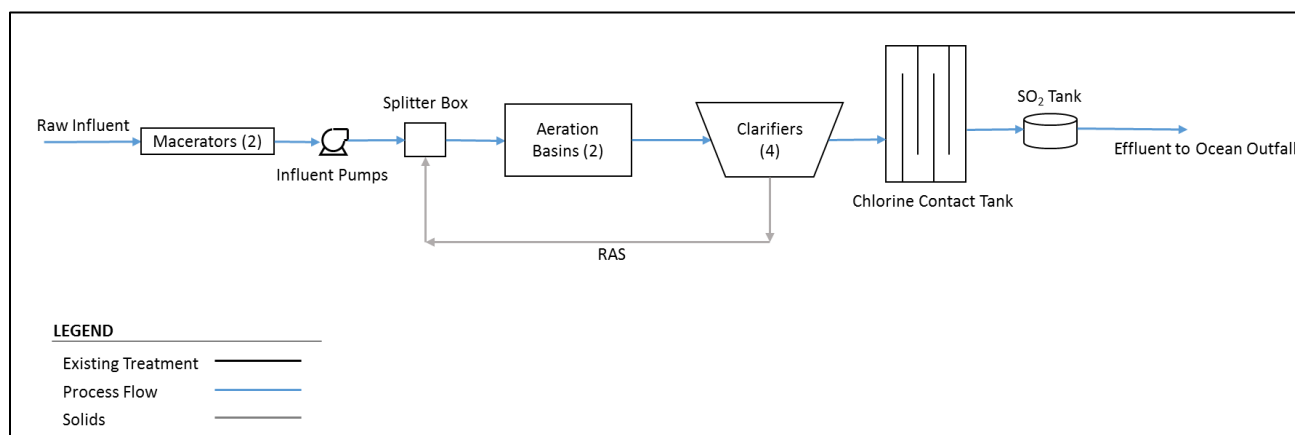

2.3.2.1 Flow Estimates

As shown in Table 9, dry weather flows have decreased steadily since 2011 as drought-related water restrictions and conservation were implemented. Monthly effluent flows for 2015 to 2018 are shown in Figure 8. The lower flows seen in December 2017 and January 2018 are a result of evacuations related to the Thomas Fire and subsequent debris flow respectively. Flows have recovered to approximately 0.5 MGD as of August 2018. Future flows may return to the recent annual dry weather flow average of roughly 0.6 MGD as hotels re-open (e.g., Biltmore, Mira Mar, Santa Ysidro Ranch), residents return, and homes are reconstructed.

Table 9: MSD Annual Dry Weather Effluent Flows, 2011-2017 (MGD)

2011	2012	2013	2014	2015	2016	2017
0.89	0.80	0.78	0.67	0.63	0.58	0.59

Source: California Integrated Water Quality System Project (CIWQS); <https://www.waterboards.ca.gov/ciwqs/>

Figure 8: Montecito WWTP Average Effluent Monthly Flows

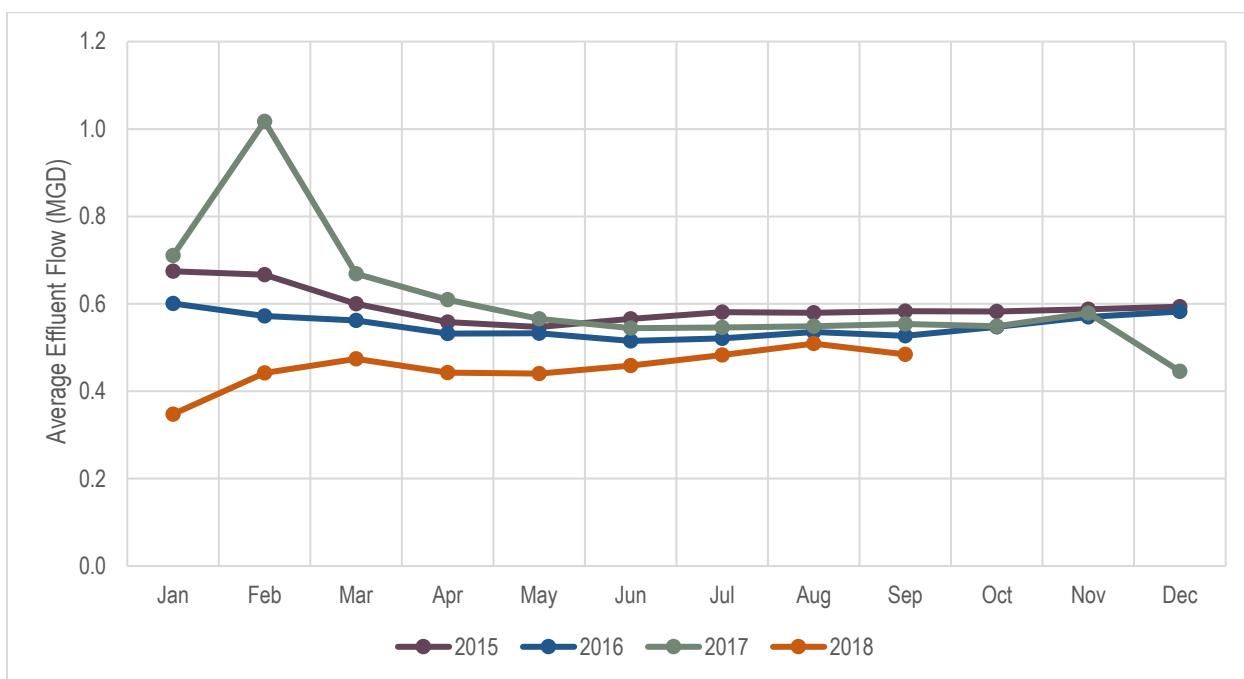

Source: California Integrated Water Quality System Project (CIWQS); <https://www.waterboards.ca.gov/ciwqs/>

2.3.2.2 Water Quality

MSD produces a secondary effluent which meets discharge limitations contained in its National Pollutant Discharge Elimination System (NPDES) permit issued by the Central Coast Regional Water Quality Control Board (RWQCB). The MSD currently operates the Montecito WWTP under NPDES Permit No. CA00047899, Order No. R3-2012-0016 for discharge of treated domestic wastewater through an ocean outfall to the Pacific Ocean. The permit became effective on December 6, 2012. Table 10 summarizes the discharge point effluent limitations for MSD.

Table 10: Montecito WWTP Effluent Limitations

Parameter	Units	Effluent Limitations				
		Average Monthly	Average Weekly	Maximum Daily	Instantaneous Minimum	Instantaneous Maximum
CBOD ₅ @ 20° C	mg/L	25	40	85	--	--
	lbs/day	310	500	1100	--	--
TSS	mg/L	30	45	90	--	--
	lbs/day	380	560	1100	--	--
pH	standard units	--	--	--	6.0	9.0
Oil and Grease	mg/L	25	40	75	--	--
	lbs/day	310	500	940	--	--
Settleable Solids	mL/L	1.0	1.5	3.0	--	--
Turbidity	NTU	75	100	225	--	--

The quality of the domestic wastewater produced by the Montecito WWTP is monitored in accordance with their permit and is documented in their annual report and summarized in Table 11.

Table 11: Average 2017 Montecito WWTP Wastewater Effluent Quality

Flow (MGD)	TSS (mg/L)	CBOD ₅ (mg/L)	NH ₃ -N (ug/L)	Oil & Grease (mg/L)	Turbidity (NTU)	pH High	pH Low	Max Effluent Cl ₂ (ug/L)	Cl ₂ Before Dechlor (mg/L)	Max Temp °F
0.61	7.0	6.6	ND	2.58	2.47	7.37	6.63	0	28.02	75.7

Source: MSD 2017 NPDES Annual Summary Report
ND=Non-Detect

2.3.3 Summerland WWTP

The Summerland Sanitary District (SSD) is an independent special district which was voted into existence by the citizens of Summerland in 1957. The SSD provides wastewater collection, treatment, and disposal for approximately 10% of MWD's service area. The SSD operates and maintains more than eight miles of sewer pipelines, three pumping stations, a wastewater treatment plant, and a 12-inch diameter ocean outfall extending 740 feet into the Pacific Ocean. SSD maintains more than eight miles of sewer lines ranging from six inches to twelve inches in diameter.

The treatment plant was originally designed and constructed as a conventional activated sludge treatment process. Summerland WWTP currently treats approximately 0.08 MGD to secondary treatment level. In 1991 the SSD WWTP added anthracite media filtration which meets recycled water filtration requirements. However, because the chlorine contact chamber is upstream of filtration and does not have the process reliability features to meet Title 22 recycled water requirements (refer to Section 3.3.1) additional facilities are needed to produce tertiary disinfected recycled water.

Figure 9: Summerland WWTP Flow Schematic

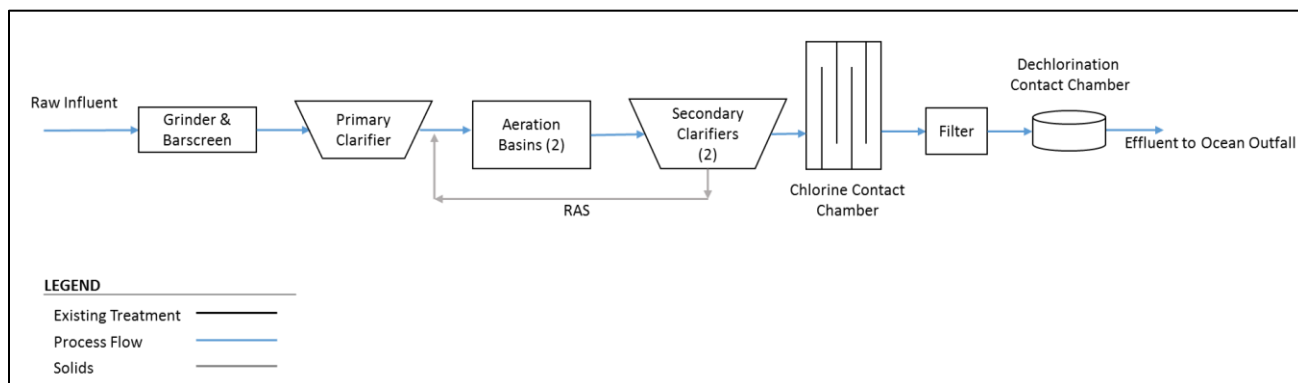

2.3.3.1 Flow Projections

As shown in Table 12, dry weather flows decreased in 2016 after drought-related water restrictions and conservation were implemented but have recovered since then. Monthly influent flows for 2015 to 2018 are shown in Figure 10.

Table 12: SSD Annual Dry Weather Flows, 2011-2017 (MGD)

2011	2012	2013	2014	2015	2016	2017
0.12	0.09	0.09	0.08	0.08	0.06	0.10

Source: Source: California Integrated Water Quality System Project (CIWQS); <https://www.waterboards.ca.gov/ciwqs/>

Figure 10: Summerland WWTP Average Effluent Monthly Flows

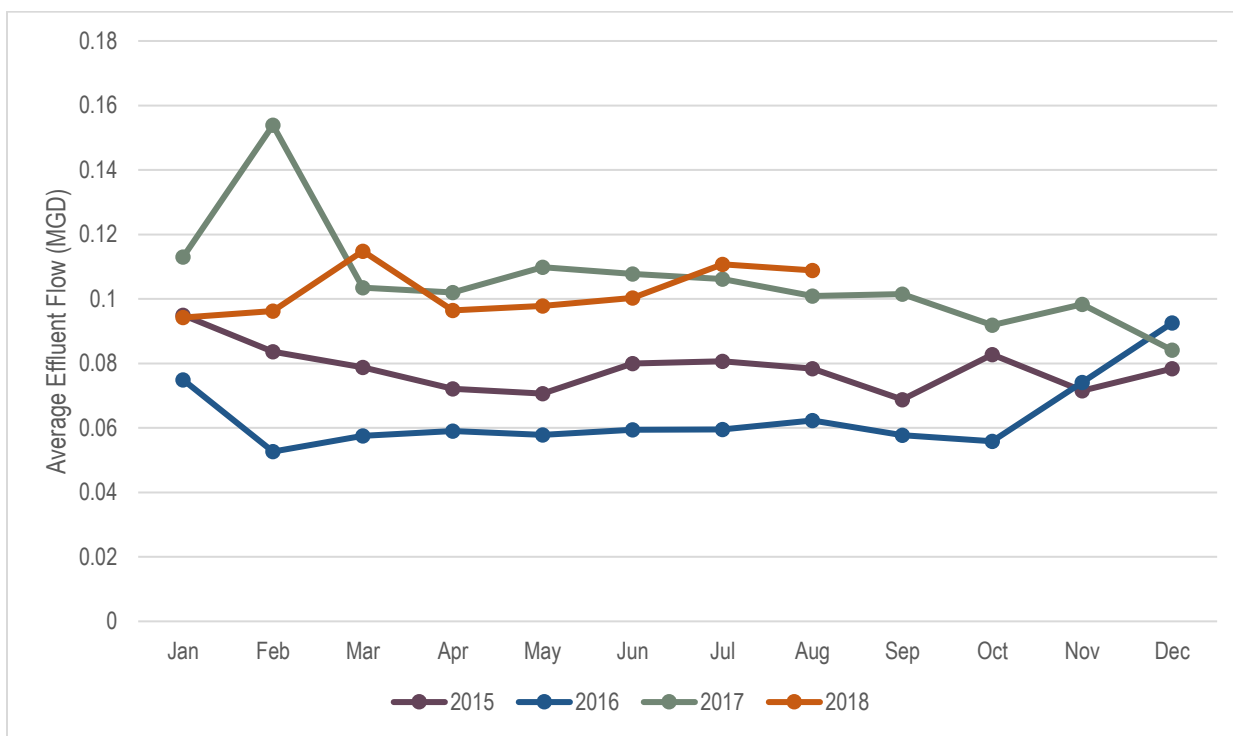

Source: California Integrated Water Quality System Project (CIWQS); <https://www.waterboards.ca.gov/ciwqs/>

2.3.3.2 Water Quality

SSD treats domestic wastewater at the Summerland WWTP to meet discharge limitations contained in its NPDES permit No. CA0048054, Order No. R3-2013-0042 issued by the Central Coast RWQCB. Treated effluent is disposed of through an ocean outfall to the Pacific Ocean via the Santa Barbara Channel. The permit became effective on December 5, 2013. Table 13 summarizes the discharge point effluent limitations for SSD.

Table 13: Summerland WWTP Effluent Limitations

Parameter	Units	Effluent Limitations				
		Average Monthly	Average Weekly	Maximum Daily	Instantaneous Minimum	Instantaneous Maximum
BOD ₅ @ 20° C	mg/L	30	45	90	--	--
	lbs/day	75	113	225	--	--
TSS	mg/L	30	45	90	--	--
	lbs/day	75	113	225	--	--
pH	standard units	--	--	--	6.0	9.0
Oil and Grease	mg/L	25	40	75	--	--
	lbs/day	63	100	188	--	--
Settleable Solids	mL/L	1.0	1.5	3.0	--	--
Turbidity	NTU	75	100	225	--	--

The Summerland WWTP effluent water quality is reported annually in accordance to their permit and the 2016 effluent quality is summarized in Table 14.

Table 14: Average 2017 Summerland WWTP Wastewater Effluent Quality

Flow (MGD)	TSS (mg/L)	BOD (mg/L)	NH ₃ -N (ug/L)	Turbidity (NTU)	pH High	pH Low	Cl ₂ (mg/L)	TC (MPN/100 mL)
0.106	2.9	4.3	0.015	1.045	7.1	6.6	15	8.16

Source: Summerland Sanitary District 2017 Annual Summary Report

Note: ND= Non-Detect

2.3.4 El Estero WWTP

The City of Santa Barbara owns and operates the El Estero WWTP, which was constructed in 1979 and has a design capacity of 11.0 MGD. The City's wastewater collection system consists of 251 miles of sewer pipe and 7 lift stations. The El Estero WWTP provides wastewater collection and treatment for approximately 3% of MWD's service area along Coast Village Road. In 1989, a 3.0 MGD ultrafiltration tertiary facility was added to treat a portion of the flows. Secondary effluent that does not go through the tertiary treatment process is discharged to the Pacific Ocean.



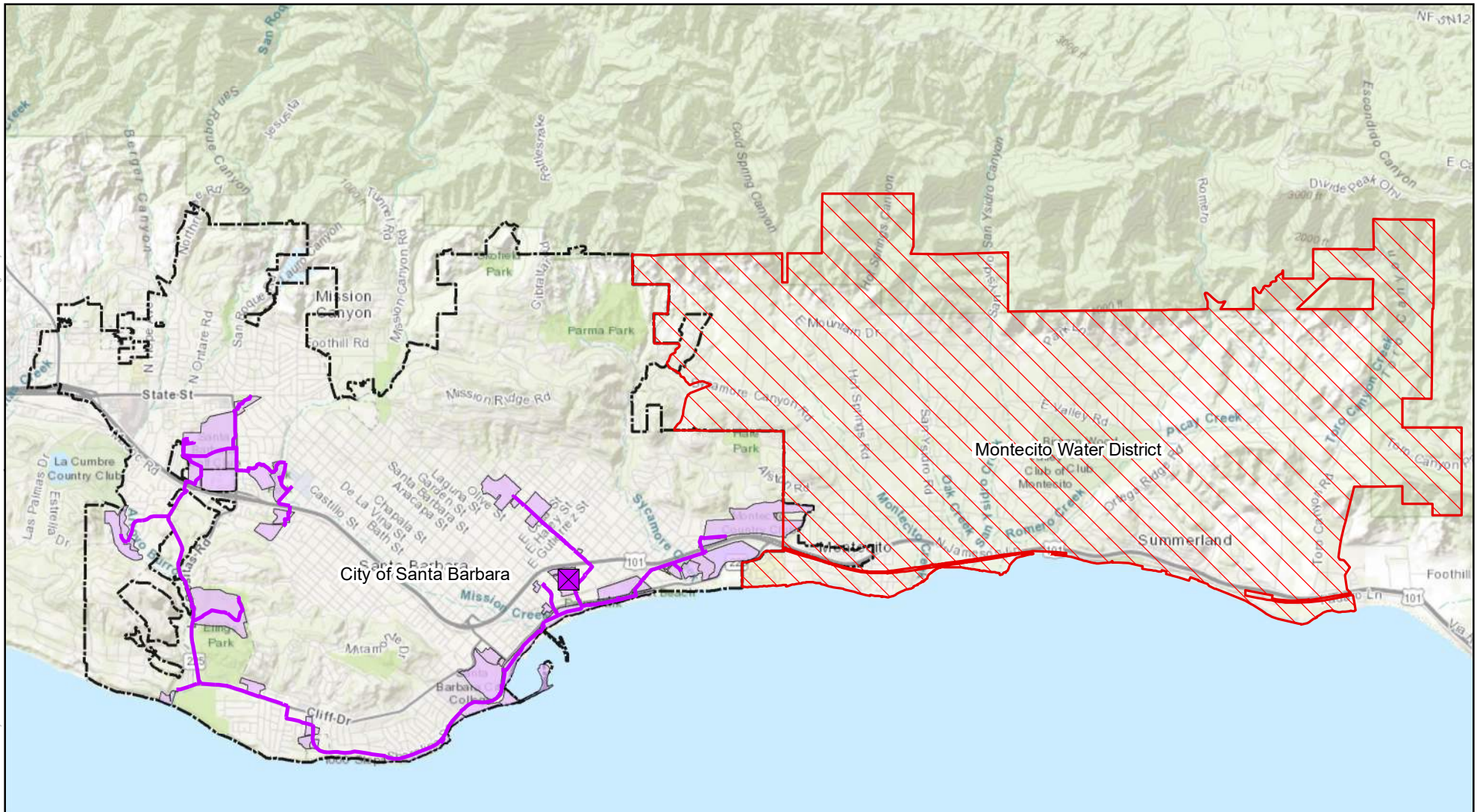

The City supplies recycled water to parks, schools, commercial landscapes, golf courses, and public restrooms. The City's system has the capacity to treat and deliver approximately 1,400 AFY of recycled water, the current demand is 800 AFY in addition to 300 AFY of process water used at the plant. The recycled water system includes 14.8 miles of recycled water distribution pipelines, as shown in Figure 11.

Figure Exported: 10/31/2018 By: mdemania Using: \\woodardcurran.net\shared\Projects\RM\CL\0695\Montecito Water District\0011083_00 MWD RW Facilities Plan\GIS\MXDs\Existing Recycled Water Facilities.mxd



MWD Recycled Water Facilities Plan Figure 11 Existing Recycled Water Facilities

Legend

-  El Estero WWTP
-  Existing Recycled Water Mains
-  Existing Recycled Water Customers
-  City of Santa Barbara

 Montecito Water District



Project #: 0011083
Map Created: November 2018

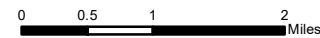

Third Party GIS Disclaimer: This map is for reference and graphical purposes only and should not be relied upon by third parties for any legal decisions. Any reliance upon the map or data contained herein shall be at the users' sole risk. **Data Sources:**

ADMIN DRAFT

Figure 11: Existing Recycled Water Facilities

3. REGULATORY, PERMITTING, AND LEGAL REQUIREMENTS

This chapter identifies the existing regulatory, permitting, and legal requirements for implementing recycled water projects, which entail non-potable reuse (e.g., landscape irrigation) and groundwater replenishment. This chapter is organized into the following sections:

- Types of reuse
- Regulatory Overview
- State Water Resources Control Board (SWRCB) regulations
- SWRCB Policies
- Regional Water Quality Control Board (RWQCB) requirements
- Permitting recycled water projects

3.1 Types of Reuse

The most common type of recycled water use in California is non-potable reuse (NPR) (sometimes referred to as “purple pipe”). Approved non-potable end uses include irrigation of golf courses, cemeteries, freeway landscaping, parks, playgrounds, school yards, and common area landscaping; agricultural irrigation; process feedwater, such as industrial or commercial cooling or boilers; and flushing toilets and urinals.

There is increasing interest in the use of recycled water for potable reuse. There are two types of potable reuse: Indirect Potable Reuse (IPR) and Direct Potable Reuse (DPR). IPR involves the blending of recycled water in a groundwater basin or surface water reservoir where it mixes with water prior to treatment and delivery. DPR removes the environmental barrier (e.g., groundwater basin or surface water reservoir) and involves delivering AWT water directly into a potable water system or raw water system upstream of an existing water treatment plant. The range of potable reuse concepts can be further grouped into four general categories:

- Groundwater augmentation: The planned use of recycled water for replenishment of a groundwater basin or aquifer that has been designated as a source of water supply for a public water system.
- Reservoir water augmentation: The planned placement of recycled water into a raw surface water reservoir used as a source of domestic drinking water supply for a public water system or into a constructed system conveying water to such a reservoir.
- Raw water augmentation: The planned placement of recycled water into a system of pipelines or aqueducts that deliver raw water to an existing drinking water treatment plant that provides water to a public water system.
- Treated drinking water augmentation: The planned placement of recycled water into the water distribution system of a public water system.

3.2 Regulatory Overview

The SWRCB was created in 1967 to protect water resources throughout California by setting and enforcing statewide policies. Within the SWRCB, DDW regulates public drinking water systems and oversees water recycling projects. Regional Water Quality Control Boards (RWQCBs) oversee surface water, groundwater, and coastal waters.

The SWRCB divides the state into branches and regions to address local differences in climate, topography, geology and hydrology. Drinking water and recycled water in MWD’s service area are regulated by Region IV of DDW’s Southern Field Operations Branch, which covers the counties of Los Angeles, Ventura, Santa Barbara, and San Luis Obispo. Surface water, groundwater, and coastal waters within MWD’s service area are regulated by the Central Coast RWQCB.

State statutes and regulations pertaining to the use of recycled water in California can be found in the California Water Code (CWC), California Code of Regulations (CCR), and California Health and Safety Code (H&SC). A complete compendium of applicable statutes is available on the DDW website.

Table 15: Key California Statutes for Protection of Water Quality and Public Health

Code	Purpose
Recycled Water Definitions	
CWC sections 13050, 13512, 13576, 13577, 13350, and 13552-13554	Recycled water is defined in the CWC as water, which as a result of treatment of waste, is suitable for a direct beneficial use or a controlled use that would not otherwise occur and therefore considered a valuable resource.
CWC sections 13561	Defines types of reuse
Recycled Water Permits	
CWC sections 13260, 13263, 13269, 13523.1	Dischargers proposing to discharge waste that could affect the quality of waters of the state must file a report of waste discharge (ROWD) to the RWQCB. After receiving this report, the RWQCB can issue specific or general Waste Discharge Requirements (WDRs) and/or Water Recycling Requirements (WRRs) that reasonably protect all beneficial uses and that implement any relevant water quality control plans and policies. The RWQCB can also issue a Master Reclamation Permit, which is a WDR that covers multiple non-potable reuse applications and requires periodic site inspections and adoption of rules and regulations for recycled water use. A RWQCB may require a discharger to provide monitoring program reports or conduct studies.
Recycled Water Regulations	
CWC sections 13500-13529.4; H&SC 116800 et seq.	Requires DDW to establish uniform statewide recycling criteria. DDW has developed these criteria for non-potable reuse, groundwater augmentation, and reservoir water augmentation and they are codified in Title 22 of the California Code of Regulations; regulations for cross connections are codified in Title 17.
CCR Title 17 and Title 22	DDW's regulations related to recycled water. Title 17 requires the protection of water systems through the use of backflow preventers. Title 22 contains criteria for recycled water quality based on usage, requirements for dual plumbed recycled water systems, requirements for groundwater augmentation and reservoir water augmentation.
CWC sections 13522.5 and 13523	Requires any person who proposes to recycle or to use recycled water to file an Engineering Report with the RWQCB on the proposed use. After receiving the report, and consulting with and receiving recommendations from DDW, and any necessary evidentiary hearing, the RWQCB must issue a permit (WDRs and/or WRRs) for the use.
Water Quality	
CWC section 13170	Authorizes the SWRCB to adopt State policies for water quality control.
CWC sections 13240-42	Authorizes RWQCB to adopt Water Quality Control Plans (Basin Plans) that assign beneficial uses for surface waters and groundwaters and contain numeric and narrative water quality objectives that must provide reasonable protection of the beneficial uses of the groundwater. One of the factors that must be considered when establishing water quality objectives is the need to develop and use recycled water.
H&SC sections 116270 et seq.	This is the California Safe Drinking Water Act that authorizes primary and secondary maximum contaminant levels (MCLs) as included in the California Code of Regulations, Title 17 – Public Health, Chapter 5, Subchapter 1, Group 4 – Drinking Water Supplies, sections 7583 through 7630.
Water Rights	
CWC section 1211	Requires that prior to making any change in the point of discharge, place of use, or purpose of treated wastewater, approval must be obtained from the SWRCB. New SWRCB guidance has clarified that a wastewater petition for change only needs to be filed with the SWRCB Division of Water Rights if the owner of the wastewater treatment plant decreases the amount of water in a stream or other waterway.

3.3 SWRCB Regulations

Applicable DDW recycled water regulations are presented in the following sections:

- Non-potable reuse regulations
- Indirect potable reuse regulations
- Direct potable reuse regulations

3.3.1 Non-Potable Reuse Regulations

DDW sets forth water recycling criteria, including water quality standards, treatment process requirements, operational requirements, and treatment reliability requirements as part of the California Code of Regulations Title 22, Division 4, Chapter 3, Article 7 (Title 22). Recycled water meeting Title 22 disinfected tertiary treated requirements for unrestricted reuse can be used for the greatest variety of uses, including:

- Irrigation of golf courses, cemeteries, freeway landscaping, parks, playgrounds, school yards, and common area landscaping.
- Agricultural irrigation
- Process feedwater, such as industrial or commercial cooling or boilers
- Flushing toilets and urinals
- Groundwater recharge via surface spreading (Refer to Section 3.3.2 for further information).

3.3.2 Groundwater Replenishment Reuse Regulations

The California Water Code defines groundwater replenishment reuse project (GRRP) as the planned use of recycled water for replenishment of a groundwater basin or aquifer that has been designated as a source of water supply for a public water system. Beginning in 1976, the California Department of Public Health issued numerous draft versions of detailed GRRP regulations that served as guidance for the seven permitted GRRP projects in California. Final GRRP regulations were adopted and went into effect June 18, 2014. The GRRP regulations are organized by type of project: Surface application (surface spreading); and Subsurface application (injection or vadose zone wells). The key provisions of the GRRP regulations are presented in Table 16 for both surface and subsurface application projects.

Table 16: Title 22 Groundwater Recharge Regulations

	Surface Application	Subsurface Application
Source Control	Must administer a comprehensive source control program to prevent undesirable chemicals from entering raw wastewater. The source control program must include: (1) an assessment of the fate of DDW and RWQCB-specified contaminants through the wastewater and recycled water treatment systems; (2) provisions for contaminant source investigations and contaminant monitoring that focus on DDW and RWQCB-specified contaminants; (3) an outreach program to industrial, commercial, and residential communities; and (4) an up-to-date inventory of contaminants.	
Boundaries Restricting Construction of Drinking Water Wells	Must establish (1) a “zone of controlled potable well construction,” which represents the greatest of the horizontal and vertical distances reflecting the retention times required for pathogen control or for response retention time; and (2) a “secondary boundary” representing a zone of potential controlled potable well construction that may be beyond the zone of controlled potable well construction thereby requiring additional study.	
Emergency Response Plan	Must develop and be willing to implement a DDW-approved plan for an alternative source of potable water supply or treatment at a drinking water well if a GRRP project causes the well to no longer be safe for drinking purposes.	

	Surface Application	Subsurface Application
Adequate Managerial and Technical Capability	Must demonstrate adequate managerial and technical capability to comply with the regulations. <i>Note: DDW has indicated that project sponsors can use the drinking water Technical Managerial and Financial Assessment to demonstrate compliance with this requirement.</i>	
Pathogen Control	<ul style="list-style-type: none"> The treatment system must achieve a 12-log enteric virus reduction, a 10-log <i>Giardia</i> cyst reduction, and a 10-log <i>Cryptosporidium</i> oocyst reduction using at least 3 treatment barriers. For each pathogen, a separate treatment process can only be credited up to a 6-log reduction and at least 3 processes must each achieve no less than 1.0-log reduction. Retention time credit for virus of 1-log/month (up to 6-logs) can be counted; the retention time must be validated by an added or intrinsic tracer approved by DDW. 	
	<ul style="list-style-type: none"> Must meet Title 22 disinfected tertiary effluent requirements. <i>Giardia/Cryptosporidium</i> Credit: If a project meets Title 22 disinfected tertiary effluent requirements or provides advanced treatment for the entire flow, and 6 months' retention underground, a project will be credited with 10-log <i>Giardia</i> cyst reduction and 10-log <i>Cryptosporidium</i> oocyst reduction. 	
Nitrogen (N) Control	Total N must be less than 10 mg/L as N in recycled water or recharge water before or after application. <i>Note: The nitrogen requirements may be more stringent based on the RWQCB Basin Plan groundwater objectives.</i>	
Regulated Chemicals Control	<p>Recycled Water: Must meet all primary Maximum Contaminant Levels (MCLs), with the exception of nitrogen compounds; for disinfection byproducts, for surface application projects, compliance can be determined in the recycled water or the recharge water before or after surface application and for subsurface application projects in the recycled water or recharge water; for secondary MCLs, compliance can be determined in recycled water or recharge water.</p> <p>Diluent Water: Must meet primary and secondary MCLs based on upper limit if not historically used for recharge (except for secondary MCLs for color, turbidity, and odor).</p>	
Notification Level (NL)	<p>Recycled Water: Regulatory action to be taken if NL is exceeded in the recycled water or recharge water after application (excluding the effects of dilution), including additional monitoring.</p> <p>Diluent Water: Must ensure that diluent water does not exceed NL and have a plan in place prior to the operation of a project on actions to be taken if exceeded; diluent water must meet NLs.</p>	
Total Organic Carbon (TOC)	TOC _{max} = 0.5 mg/L ÷ RWC in undiluted recycled water	Recycled water TOC = 0.5 mg/L.
Initial Recycled Water Contribution (RWC)	The RWC averaging period is 120 months.	
	<ul style="list-style-type: none"> Up to 20% unless an alternative initial RWC is approved by DDW 	<ul style="list-style-type: none"> To be determined by DDW
Increased RWC	For projects starting at lower initial RWCs, sequential incremental increases ≥ 50% and ≥ 75% are allowed if: The TOC 20-week average for prior 52 weeks = 0.5 mg/L ÷ RWC _{max}	Increases allowed if: <ul style="list-style-type: none"> The TOC 20-week average for prior 52 weeks = 0.5 mg/L.
Application of Advanced Treatment	Advanced treatment is only needed for that portion of recycled water needed to meet the TOC/RWC requirements desired by the project sponsor.	Advanced treatment must be applied to the full recycled water volume.

	Surface Application	Subsurface Application
Soil Aquifer Treatment (SAT) Performance / CEC Monitoring	<ul style="list-style-type: none"> Monitor recycled water or recharge water before and after recharge for 3 indicator constituents of emerging concern (CECs) with reductions < 90% triggering investigation. If a project sponsor demonstrates there are not 3 indicator compounds available and suitable for indicating a 90% reduction, a project sponsor may utilize an indicator compound that achieves a reduction less than 90% pending DDW approval of the compound and reduction criteria. Project sponsors must conduct a DDW approved CEC occurrence study prior to operation and then every 5 years. 	None.
Response Retention Time (RRT)	<ul style="list-style-type: none"> RRT is the time recycled water must be retained underground to identify treatment failure and implement actions so that inadequately treated recycled water does not enter a potable water system, including the plan to provide an alternative water supply or treatment. The minimum RRT is 2 months, but it must be justified by the project sponsor. The RRT must be validated using an added tracer or a DDW approved intrinsic tracer. 	
Alternatives	Allowed for all provisions in the regulations if: <ul style="list-style-type: none"> The project sponsor has demonstrated that the alternative provides the same level of public health protection. The alternative has been approved by DDW. If required by DDW or RWQCB, the project sponsor will conduct a public hearing. An expert panel must review the alternative <u>unless</u> otherwise specified by DDW. 	
Engineering Report	The project sponsor must submit an Engineering Report to DDW and RWQCB that indicates how a GRRP project will comply with all regulations and includes a contingency plan to ensure that no untreated or inadequately treated water will be used. The report must be approved by DDW.	

Section 4.2 concludes that conducting recharge via surface spreading is not economical in the study area due to limited unconfined areas, high cost of land acquisition, and substantial number of private wells in the unconfined area. Therefore, groundwater augmentation is proposed via injection (referred to as “subsurface application” in above table). Injection of recycled water requires advanced water treatment (AWT), which consists of reverse osmosis (RO) and advanced oxidation process (AOP). RO is typically preceded by microfiltration or ultrafiltration (UF).

The key issue to address for an injection project is meeting minimum underground retention time requirements. The regulations include two requirements that relate to retention time: 1) Response retention time (RRT); and 2) Pathogen control. The largest of the retention times required (RRT or Pathogen Control) is used to establish the zone within which drinking water wells cannot be constructed (this effectively establishes a boundary between potable and non-potable use of the groundwater basin).

RRT is the time recycled water must be retained underground to identify any treatment failure and implement actions so that inadequately treated recycled water does not enter a potable water system, including the time to provide an alternative water supply or treatment. The minimum RRT is 2 months.

Pathogen control is achieved by meeting 12-log enteric virus reduction, 10- log Giardia cyst reduction, and 10-log Cryptosporidium oocyst reduction using at least 3 treatment barriers. For each pathogen, a separate treatment process can only be credited up to a 6-log reduction and at least 3 processes must each achieve no less than a 1.0-log reduction. Log removal credit is allowed for virus only of 1-log/month of retention time. AWT meets the giardia and crypto log removal requirements but meeting minimum 12-log virus removal may require some retention time depending on credits provided to the treatment system (WWTP and AWT). The treatment system can receive 6-log to 12-log virus removal credits on other projects but the higher credits relied on site-specific virus removal studies. Therefore, up to 6-months travel time may be required to meet virus log removal requirements in the absence of site-specific virus removal studies.

Therefore, minimum retention time ranges from 2 months (based on minimum RRT) to 6 months (based on conservative virus log removal needs). The regulations allow use of groundwater modeling to estimate residence times for project facility siting. A project sponsor must validate retention time using an added or intrinsic tracer within the first three months of operation.

3.3.3 Reservoir Water Augmentation Regulations

The reservoir water augmentation regulations were adopted on October 1, 2018. Due to the distance to Jameson Lake and Lake Cachuma, no feasible projects were identified and, therefore, the regulations are not presented in this report.

3.3.4 Direct Potable Reuse Regulations

DDW established regulations for groundwater augmentation in 2014 and reservoir water augmentation in 2018 but has only recently begun investigating raw water augmentation and treated drinking water augmentation. Raw and treated drinking water augmentation remove the environmental barrier, such as the groundwater basin, between the recycled water and potable water use and focus on engineered measures to replace the environmental barrier, such as:

- More robust treatment barriers
- Additional treatment barriers (redundancy)
- Enhanced monitoring for chemicals, pathogens, or surrogates
- High frequency monitoring capability
- Storage of product water to provide retention time (engineered storage buffer)
- Means to quickly respond to “off-spec” water (time to respond)

Chief among these considerations is the requirement for enhanced monitoring and response strategies given the lack of substantive environmental buffer. Regardless of the type, DPR projects will need to link emerging enhanced monitoring techniques with engineered storage and a response protocol that provides assurance that any treatment failures can be identified and controlled prior to off-spec water entering the water supply system.

In 2017, the California Legislature enacted AB 574 which required DDW to develop raw water augmentation regulations by 2023. The regulations will be built on DDW’s *Proposed Framework for Regulating Direct Potable Reuse in California* (April 2018). This report was built upon DDW’s *Investigation on the Feasibility of Developing Uniform Water Recycling Criteria for Direct Potable Reuse* (December 2016), *Expert Panel Final Report: Evaluation of the Feasibility of Developing Uniform Water Recycling Criteria for Direct Potable Reuse* (August 2016), and *Recommendations of the Advisory Group on the Feasibility of Developing Uniform Water Recycling Criteria for Direct Potable Reuse* (June 2016).

3.3.4.1 Expert Panel Report Key Findings

The Expert Panel determined that “it is feasible to develop uniform water recycling criteria for DPR that would incorporate a level of public health protection as good as or better than what is currently provided in California by conventional drinking water supplies...” The panel noted that the functionality provided by the environmental buffer (i.e., storage, attenuation, and response time) in an indirect potable reuse (IPR) project must be addressed by other means for DPR.

Given the lack of an environmental buffer, the Expert Panel stressed that reliability would be the overarching goal for a DPR option to consistently achieve the desired water quality in the product water. The Panel defined a reliable system as redundant, robust and resilient. The panel suggested that DPR regulations must provide reliability by:

- Providing multiple, independent treatment barriers;

- Incorporating the frequent monitoring of surrogate parameters at each step to ensure treatment processes are performing properly; and
- Developing and implementing rigorous response protocols (such as a formal Hazard Analysis Critical Control Point system).

The Expert Panel Report provides a number of example treatment trains for the range of potable reuse projects, as shown in Figure 12. The two trains above the dashed line represent groundwater augmentation and raw water augmentation, respectively. The trains below the dashed line represents different potential treatment trains for potable reuse.

Figure 12: Example Potable Reuse Treatment Trains

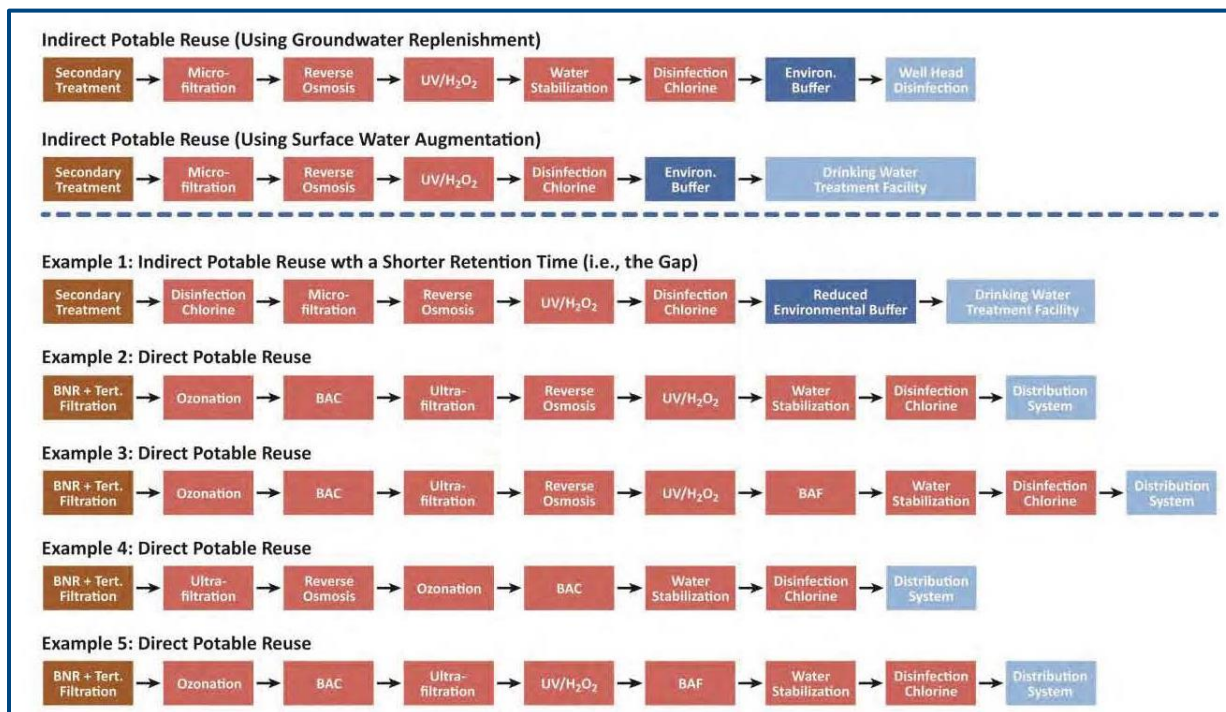

Source: Expert Panel Final Report: Evaluation of the Feasibility of Developing Uniform Water Recycling Criteria for Direct Potable Reuse (Olivieri et. al., 2016). Figure 8-1.

3.3.4.2 DDW Framework Key Findings

The purpose of the DDW's *Proposed Framework for Regulating Direct Potable Reuse in California* was to provide a common framework across various types of DPR to help avoid discontinuities in the risk assessment / risk management approach. The document evaluates how various factors are expected to change over the range of potable reuse form and show how public health will be protected.

The document focuses on risk management for pathogens and chemicals. Risk management tools for pathogens includes log removal values, environmental buffer, engineered treatment, monitoring, control system, quantitative microbial risks assessment, probabilistic analysis of treatment rain performance. Risk management tools for chemicals include health goals, wastewater treatment optimization, more effective source control, public education, notification levels, use of surrogates and indicators, control systems, and peak attenuation.

3.3.4.3 Potable Reuse Treatment Assumptions

Typically, the selection of treatment processes is driven by several common regulatory requirements: (1) low bulk organic limits (e.g., TOC, COD); (2) requirements for pathogen log reduction; and (3) the use of multiple treatment barriers to control pathogens and chemicals, including trace organics (Mosher et. al., 2016). The common advanced treatment train consists of microfiltration (MF) or ultrafiltration (UF), reverse osmosis (RO), and an advanced oxidation process (AOP) and is designed to meet DDW 12/10/10 (enteric viruses/cryptosporidium/giardia) log removal requirements. UF or UF removes residual particulate matter, RO demineralizes and removes chemical constituents, and AOP is used to destroy or alter chemical constituents that are not oxidized completely by conventional biological treatment processes or removed by filtration; AOP also provides disinfection benefits. AOP includes ultraviolet (UV) disinfection with hydrogen peroxide, ozonation, or chlorination.

In addition to UF/RO/AOP, the example potable reuse treatment trains in Figure 12 include several additional unit processes:

- Biological Nutrient Removal (BNR) for removal of nitrogen and phosphorus and decreased fouling rates for MF or UF membranes. Denitrification also has the added benefit of reducing the degree of nitrate removal that must be achieved in the AWTF (Tchobanoglous et. al. 2015).
- Tertiary Filtration can be used to reduce a measure of complexity and the effects of close-coupled processes in DPR systems. For example, a biological process upset that increases the suspended solids and turbidity of secondary effluent will negatively affect downstream membrane performance, but the impact will be reduced with the use of tertiary filtration to capture and reduce the particle load (Tchobanoglous et. al. 2015).
- Disinfection of secondary or tertiary filtered effluent can add a redundant disinfection barrier to the subsequent AWTF, with the level of redundancy and a possible measure of robustness depending upon the disinfection technology (Tchobanoglous et. al. 2015).
- Ozone in DPR trains may be used for the pretreatment of MF or UF for flux improvement, oxidation of organic matter including trace organics, and disinfection of pathogens. Ozone can form significant concentrations of NDMA, although the use of downstream biological activated carbon (BAC) has been shown to effectively remove NDMA that has formed (Mosher et. al., 2016).

Blending Assumptions

Raw water augmentation assumes AWT water is limited to no more than 50% of source water to the surface WTP at any point in time due to concerns regarding impacts to WTP operations and DDW may not issue full log removal credit for the WTP. The blending assumption could limit use of AWT water during times of extreme drought when Cachuma and SWP supplies are extremely limited.

Treated water augmentation blending requirements are also assumed to be limited to no more than 50%; however, there has been little regulatory discussion on the topic to date.

Treatment Trains

Assumed minimum levels of treatment were developed for raw water augmentation and treated water augmentation based on the key considerations described in Section 3.3.3; the anticipated conservative nature of forthcoming potable reuse regulations; and treatment trains currently being developed by agencies considering potable reuse based on the DDW recommendations. The treatment train is assumed to include secondary wastewater treatment followed by advanced water treatment using UF/RO/AOP (AWT), as currently required for groundwater augmentation via injection. The treatment train would also include additional treatment processes and critical control point monitoring to provide a reliable system that is redundant (multiple barriers), robust (combination of technologies), and resilient (combination of protocols and strategies) (Pecson et. al., 2015).

The assumed raw water augmentation treatment train for this report builds upon the AWTF for groundwater augmentation. Extra processes include biological nutrient removal added to secondary treatment and a second chlorine (Cl) disinfection step added to the AWTF in addition to ultimately being treated at a conventional drinking water treatment facility that meets surface water treatment rules. The assumed raw water augmentation treatment train is referred to as “AWT+” in this report.

Treated water augmentation may require additional barriers to address acutely toxic constituents. The assumed treatment train for this report assumes secondary treatment with BNR followed by full tertiary treatment. The subsequent AWTF includes a redundant disinfection process (chlorine disinfection) and redundant organics removal processes (ozone (O₃) followed by biological activated carbon (BAC)). The assumed treated water augmentation treatment train is referred to as “AWT++” in this report.

In summary, the following treatment trains are assumed for potable reuse:

- Groundwater Augmentation:
 - Secondary wastewater treatment
 - “AWT” (UF/RO/AOP)
- Raw Water Augmentation:
 - Secondary wastewater treatment with biological nutrient removal
 - “AWT+” (UF/RO/AOP + Cl)
- Treated Drinking Water Augmentation:
 - Secondary wastewater treatment with biological nutrient removal
 - Tertiary treatment
 - “AWT++” (UF/RO/AOP + Cl + O₃/BAC)

It should be noted that the minimum treatment, storage, and monitoring requirements for the potable reuse options without regulations (raw water augmentation and treated drinking water augmentation) are based on an interpretation of the ongoing DPR regulatory discussion. These requirements will be subject to change once regulations are finalized for each type of potable reuse. Future regulations could be more or less conservative than the assumptions in this report.

Also, developing regulations for treated water augmentation will require a better understanding of DPR issues. Many of these issues are expected to be better understood as data are collected from operating raw water augmentation projects.

Engineered Storage

Engineered storage provides time to analyze, interpret, and respond to issues. The raw water augmentation alternatives assume three tanks with at least two hours of storage while the treated drinking water augmentation alternatives include three tanks with at least six hours of storage. The storage size is based on the best available information at this time and will be better defined as part of DPR regulations development.

3.4 State Water Resources Control Board Policies

Two types of policies have particular importance with respect to recycled water projects for protection of water quality and human health:

- Anti-degradation Policies
- Recycled Water Policy

3.4.1 Anti-degradation Policies

California's anti-degradation policies are found in Resolution 68-16, Policy with Respect to Maintaining Higher Quality Waters in California and Resolution 88-63, Sources of Drinking Water Policy. These resolutions are binding on all State agencies. They apply to both surface water and groundwater, protect both existing and uses, and are incorporated into RWQCB Basin Plans.

3.4.2 Recycled Water Policy

The Recycled Water Policy was adopted by the SWRCB in 2009, amended in 2013, and is currently being updated by the SWRCB. The Policy was a critical step in creating uniformity in how RWQCBs were individually interpreting and implementing Resolution 68-16 for water recycling projects. The critical provisions in the Policy related to landscape irrigation and GRRP projects include:

- Development of Salt and Nutrient Management Plans (SNMP)
- Requirements for landscape irrigation projects
- RWQCB GRRP requirements
- Anti-degradation and assimilative capacity
- CECs

3.4.2.1 Salt and Nutrient Management Plans

The Recycled Water Policy requires the development of SNMPs for every groundwater basin/sub-basin by May 2014 (May 2016 with a RWQCB-approved extension). The SNMP must identify salt and nutrient sources, identify basin/sub-basin assimilative capacity and loading estimates (including estimates for GRRP and landscape irrigation projects that use recycled water), and evaluate the fate and transport of salts and nutrients. The SNMP must include implementation measures to manage salt and nutrient loadings in the basin on a sustainable basis as well as an anti-degradation analysis demonstrating that all recycling projects identified in the plan will collectively satisfy the requirements of Resolution No. 68-16. The SNMP must also include an appropriate cost-effective network of monitoring locations to determine whether salts, nutrients, and other constituents (as identified in the SNMPs) are consistent with applicable water quality objectives.

3.4.2.2 RWQCB Groundwater Requirements

The Recycled Water Policy does not limit the authority of a RWQCB to include more stringent requirements for GRRP projects to protect designated beneficial uses of groundwater, provided that any proposed limitations for the protection of public health may only be imposed following consultation with DDW. In addition, the Recycled Water Policy does not limit the authority of a RWQCB to impose additional requirements for a proposed GRRP project that has a substantial adverse effect on the fate and transport of a contaminant plume (for example, those caused by industrial contamination or gas stations), or changes the geochemistry of an aquifer thereby causing the dissolution of naturally occurring constituents, such as arsenic, from the geologic formation into groundwater.

3.4.2.3 Anti-degradation and Assimilative Capacity

Assimilative capacity is typically defined as the difference between the ambient groundwater concentration and the concomitant groundwater quality objective. In accordance with the Recycled Water Policy, two assimilative capacity thresholds were established for GRRP projects in light of the type of assimilative capacity that must be conducted. A GRRP project that uses less than 10% of the available assimilative capacity in a groundwater basin/sub-basin (or multiple projects utilizing less than 20% of the available assimilative capacity in a groundwater basin/sub-basin) must conduct an anti-degradation analysis verifying the use of the assimilative capacity. In the event that a project or multiple

projects utilize more than the designated fractions of assimilative capacity (e.g., 10% or 20%), the project proponent must conduct a RWQCB-deemed acceptable anti-degradation analysis. Some SNMPs use these assimilative capacity values as thresholds for evaluating impacts of salt and nutrient loadings and implementation measures.

A landscape irrigation project that meets the Recycled Water Policy streamlining criteria, and which is also within a groundwater basin with an approved SNMP, may be approved by a RWQCB without further anti-degradation analysis if the project is consistent with the SNMP. A landscape irrigation project that meets the streamlining criteria, which is within a groundwater basin preparing an SNMP, may be approved by a RWQCB by using a salt/nutrient mass balance or equivalent analysis to demonstrate that the project uses less than 10% of the available assimilative capacity or less than 20% of the available assimilative capacity for multiple projects.

3.4.2.4 CECs

As part of the Recycled Water Policy, a Science Advisory Panel was formed to identify a list of CECs (e.g., endocrine disrupters, personal care products, or pharmaceuticals) for monitoring in recycled water used for GRRP and landscape irrigation. The Panel recommended monitoring selected health-based and treatment performance indicator CECs and surrogates for GRRP projects. The Panel concluded that CEC monitoring was unnecessary for landscape irrigation. The GRRP monitoring recommendations were directed at surface spreading using tertiary recycled water and injection projects using advanced water treatment. The purpose of monitoring performance indicator CECs and surrogates is to assess the effectiveness of unit processes to remove CECs.

The Recycled Water Policy was amended in 2013 to include the CEC monitoring program. The Amendment provides the final list of specific CECs and monitoring frequencies for GRRP projects and procedures for both evaluating the data and responding to the results. These requirements will be incorporated into the permits for existing GRRP projects and will be included as requirements for all future projects. As part of the 2014 GRRP regulations, additional CEC requirements and monitoring locations must be met in addition to the Recycled Water Policy requirements.

The panel was reconvened in 2017 and submitted an updated report in April 2018. The panel updated the list of indicator CECs for monitoring for potable reuse projects and reiterated no CEC monitoring for non-potable projects.

3.5 Central Coast RWQCB Requirements

The Central Coast RWQCB is responsible for regulating water discharges to surface water and groundwater, which are subject to State water quality regulations and statutes. The Central Coast RWQCB provides local implementation of SWRCB policies and regulations and develops and implements the 2016 Water Quality Control Plan for the Central Coastal Basin (Basin Plan) to protect surface water and groundwater quality and beneficial uses. The Basin Plan typically identifies groundwater objectives for each groundwater basin that are intended to serve as a water quality baseline for evaluating water quality management in the basin. However, the Montecito Groundwater Basin is not listed in the Basin Plan so the basin must meet general water quality objectives in the Basin Plan, which must comply with Municipal and Domestic Supply and Agricultural Supply beneficial uses.

3.6 Permitting Recycled Water Projects

The process for permitting non-potable and groundwater projects is described in this section.

3.6.1 Non-Potable Projects

3.6.1.1 SWRCB General Permit

The Water Reclamation Requirements for Recycled Water Use (General Order), adopted on June 7, 2016, replaced the existing statewide Waste Discharge Requirements for Recycled Water Use (2014-0090-DWQ) and established

standard conditions for recycled water for non-potable uses such as landscape irrigation, crop irrigation, dust control, industrial/commercial cooling, decorative fountains, etc. Potable reuse activities are not authorized under the General Order.

To obtain coverage under the General Order, an applicant must have an approved Engineering Report and submit a Notice of Intent to the RWQCB within its jurisdiction. Producers, distributors, or users of recycled water covered under existing permits may elect to continue or expand coverage under the existing permits or apply for coverage under the General Order.

3.6.1.2 Individual Non-Potable Reuse Project Permits

The DDW, as part of the SWRCB, has the statutory authority to issue WDRs and WRRs. Under the current permitting framework where the RWQCB issues the WDR/WRR permit project sponsors are required to submit an Engineering Report to DDW and RWQCB, as well as a Report of Waste Discharge to the RWQCB. In issuing the permit, the RWQCB is required to consult with DDW. Any reclamation requirements included in a permit must conform to Title 22. The RWQCBs have the option of issuing a Master Reclamation Permit in lieu of individual WRRs for a project involving multiple uses. The master permit can be issued to a recycled water supplier or distributor, or both.

3.6.2 Groundwater Replenishment Reuse Projects

The process for project approval and permitting of GRRP projects is similar to individual non-potable reuse project permits; however, the Engineering Report prepared for DDW has a more prominent role in review and approval of the project. The RWQCB would issue the permit based on requirements consistent with the GRRP Regulations, Basin Plans, SNMPs, State policies, and any requirements prescribed by DDW as part of their Engineering Report approval process. The type of permit (WDR and/or WRR) issued depends on how and where the recycled water is “discharged”.

A recent example of the process is the Pure Water Monterey Advanced Water Purification Project, which applies advanced water treatment to tertiary effluent prior to recharge of the local groundwater basin via injection wells. In March 2017, the Central Coast RWQCB approved a WDR/WRR for the project, which is first GRRP project approved under the 2014 GRRP regulations.

3.6.3 Effluent Rights

California Water Code Section 1210 states that the WWTP owner shall hold the exclusive right to the treated wastewater as against anyone who has supplied the water discharged into the waste water collection and treatment system, including a person using water under a water service contract, unless otherwise provided by agreement.

To protect downstream water rights, California Water Code Section 1211 requires that before making a change in the point of discharge, place of use, or purpose of use of treated wastewater, the WWTP owner must seek approval from the SWRCB Division of Water Rights. However, this does not apply to ocean discharges.

4. RECYCLED WATER MARKET

This chapter identifies recycled water customers or uses in the study area. non-potable uses of recycled water within the study area mainly include landscape irrigation at parks, golf courses, and schools and agricultural irrigation. The primary potable reuse option considered is groundwater augmentation (also referred to as indirect potable reuse (IPR)). Raw water augmentation and treated drinking water augmentation (also referred to as direct potable reuse (DPR)) (described in Section 3.1) are considered but regulations have not been developed for these uses so they are evaluated at a higher level than non-potable and groundwater recharge options.

4.1 Non-Potable Reuse Market

Non-potable customers were identified with the following steps:

- Meter-Based Estimate: Review MWD potable water use data for 2009 to 2017, including use since drought restrictions were implemented in 2014.
 - Estimate non-potable use for landscape irrigation based on the type of customer (i.e., school, park) by applying a percentage to potable water use (Table 17).
 - Identify sites with greater than 1 AFY of non-potable irrigation demand.
- Area-Based Estimate: Identify landscape irrigation sites with private wells that may be used to meet some or all irrigation demands based on input from MWD staff.
 - Estimate non-potable use based on irrigated acreage using Google Earth and applying a unit demand factor of 3.0 AFY per acre (based on net evapotranspiration).
 - For agricultural parcels, estimate irrigated area assuming 90% of parcel area and applying the appropriate unit demand factor (ranging from 1.5 to 3.0 AFY) by crop type using crops listed in the Santa Barbara County 2017 Crop Survey.
 - Identify sites with greater than 1 AFY of non-potable irrigation demand.

Table 17: Irrigation Demand Estimates from Metered Potable Water Use

Use Type	% of Potable Use for Irrigation
Parks, Golf Courses, Cemeteries	90%
Schools	50%
Hotels	25%

4.1.1 Landscape Irrigation

Thirteen landscape irrigation customers were identified with recycled water demands greater than 5 AFY (Figure 13 and Table 18). As shown in the table, the largest landscape irrigation customers are Valley Club, Birnam Wood Golf Club, Santa Barbara Cemetery, Bella Vista Polo Club, Westmont College, and a private residence. These customers are used as “anchor” customers for developing distribution system alternatives in Chapter 5 since high use customers are essential for cost effective non-potable recycled water systems.

Figure Exported: 10/31/2018 By: mdemania Using: \\woodardcurran.net\shared\Projects\RWC\LA\06959 Montecito Water District\0011083_00 MWD RW Facilities Plan\GIS\GISMXDs\Potential Customers.mxd

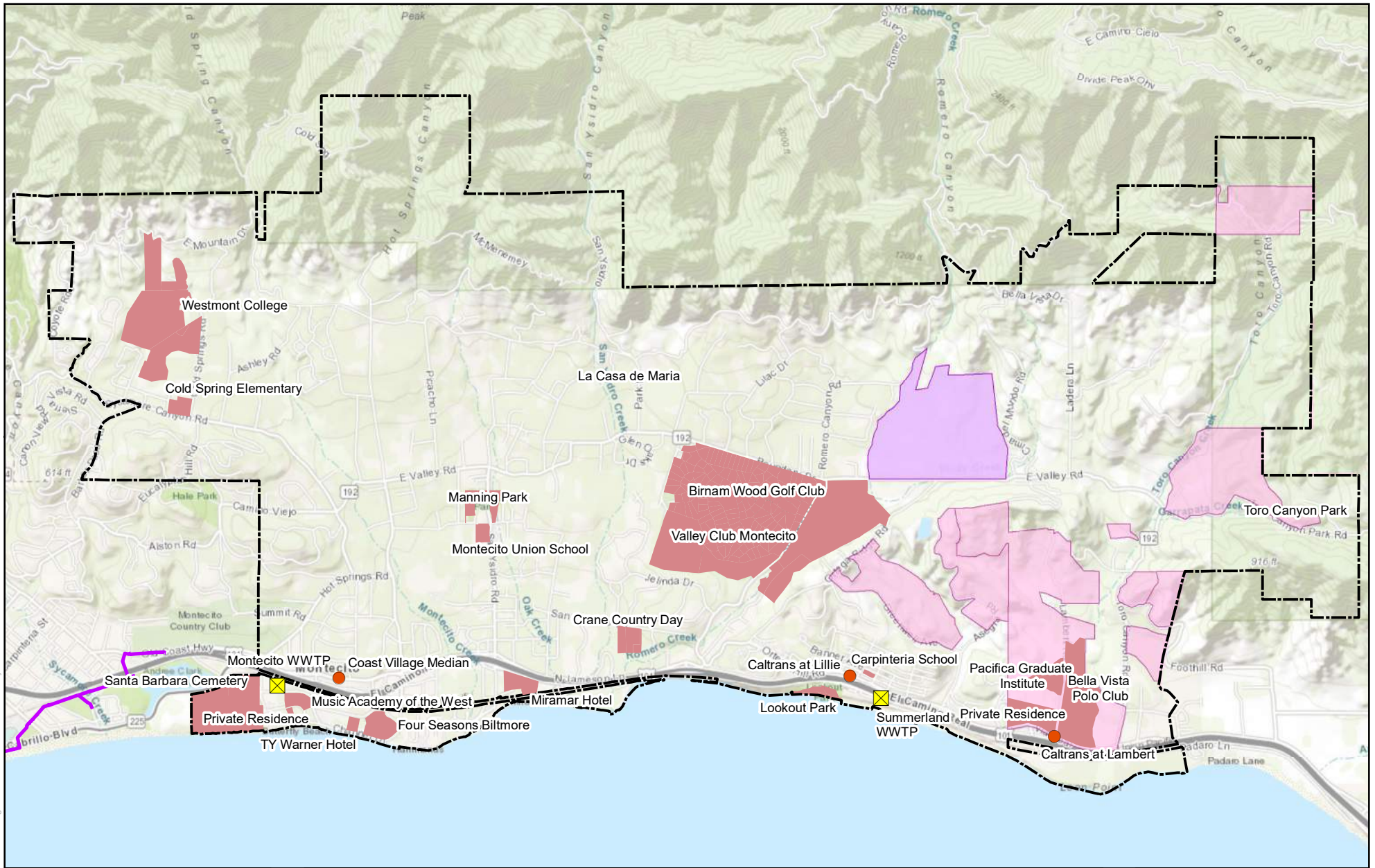

MWD Recycled Water Facilities Plan
Figure 13
Potential Recycled Water Customers in MWD Service Area

Legend	Potential Customers (Median)	WWTP
	Potential Landscape Irrigation Customer	Montecito Water District
	Potential Agricultural Irrigation Customer	City of Santa Barbara Existing Recycled Water Pipe
	Potential Agricultural Irrigation Customer not served by MWD	

Project #: 0011083
 Map Created: November 2018

Third Party GIS Disclaimer: This map is for reference and graphical purposes only and should not be relied upon by third parties for any legal decisions. Any reliance upon the map or data contained herein shall be at the users' sole risk. **Data Sources:**

Table 18: Recycled Water Customers (> 5 AFY), Landscape Irrigation

Customer	Existing Source of Water		Demand Based on Potable Water Use (AFY) ⁽¹⁾	Acreage-Based Landscape Demand Estimate	Recycled Water Demand Estimate (AFY) ⁽¹⁾	Note
	MWD	Wells				
Bella Vista Polo Club	X	X	31	80	50	3
Birnam Wood Golf Club	X	X	120	160	100	2
Cold Spring School	X	X	2	9	9	
Crane Country Day	X	X	1	7.5	7.5	
Four Seasons Biltmore	X	X	25	15	15	
Manning Park	X		6	6	6	
Mira Mar Hotel	X		11		11	4
Private Residence	X		9		9	
Private Residence	X	X	11	30	30	
Santa Barbara Cemetery	X		17	80	80	5
Ty Warner Hotels	X	X	1	6	6	
Valley Club Montecito	X	X	47	150	150	
Westmont College	X	X	18	30	30	
Other Customers < 5 FY (10)	X	X	21	N/A	19	
Total			306	522	522	

Notes:

1. Refer to Appendix A for more detailed water demand estimate information.
2. In addition to potable water, MWD currently provides approximately 60 AFY of non-potable groundwater for irrigation. Recycled water demand based on acreage (160 AFY) was reduced by 60 AFY to 100 AFY to account for continued use of non-potable groundwater.
3. MWD currently provides approximately 30 AFY of non-potable groundwater for irrigation. The recycled water demand based on acreage (80 AFY) was reduced by 30 AFY to 50 AFY to account for continued use of non-potable groundwater.
4. The Miramar Hotel is currently under construction so the irrigation estimate is based on a percentage of the estimated future potable water demand provided by MWD.
5. Santa Barbara Cemetery water use since drought restrictions (and penalties) were implemented in 2014 is roughly 20 AFY and was roughly 40 AFY prior to 2014. Demand based on irrigated acreage is roughly 120 AFY. The customer indicated that 80 AFY is a reasonable use estimate.

4.1.1.1 Recycled Water Quality

Recycled water may meet minimum water quality requirements for DDW public health protection, but some turfgrass and plants can be sensitive to specific constituents. Tertiary effluent provides suitable water quality for irrigation of most plants and turfgrasses with the exception of those that are sensitive to salt. General irrigation water quality guidelines are presented in Table 19. Most plants and turfgrasses can tolerate mineral water quality in the slight to moderate range. Recycled water from the WWTPs in the study fall within the slight to moderate degrees of restriction due to salinity (TDS, chloride, sodium). The actual sensitivity is dependent on the type of turfgrass being irrigated as well as soil type, drainage, climate, and irrigation method. In particular, sensitive turfgrass, such as golf course greens, may require additional treatment or other mitigation measures. The MSD and SSD salinity levels are in the upper range and would likely impact sensitive species without additional treatment to reduce salinity.

Table 19: Comparison of Turfgrass Irrigation Water Quality Guidelines for Salinity

Constituent	Units	Degree of Restriction of Use ⁽¹⁾			Study Area WWTPs Effluent Quality ⁽²⁾		
		None	Slight to Moderate	Severe	MSD	SSD	City ⁽³⁾
Electrical Conductivity	dS/m	0.7	0.7 to 3.0	> 3.0	2.65	1.97	2.10
Total Dissolved Solids (TDS)	mg/L	< 450	450 - 2,000	> 2,000	1,500 ⁽⁴⁾	1,200 ⁽⁴⁾	1,076
Sodium Adsorption Ratio (SAR)		< 3	3 – 9	> 9	8.2	4.2	7.3
Sodium	mg/L	< 70	> 70		399	550	282
Chloride	mg/L	< 100	> 100		570	630	364
Boron	mg/L	< 0.7	0.7 to 3.0	> 3.0	0.8	0.5	0.9

Notes:

1. Source: USEPA, 2012
2. Source: Water quality data provided by each agency.
3. City values are from a sample collected on 10/9/2018 and are lower than historical values as a result of the City incorporating desalinated water into their water supply.
4. MSD and SSD effluent TDS concentrations were analyzed using method EPA Method 200.1 while MWD groundwater TDS concentrations, which are the basis for the target TDS, were reported using Standard Method 2540. The EPA method report TDS by Summation and tends to be 10% to 20% higher so the MSD and SSD TDS concentrations were reduced by 15% for comparison with the target TDS concentration.

Salinity in recycled water can be managed by reducing salinity prior to distribution, at the customer site, and on-site soil mitigation measures. The primary options to reduce salinity in delivered recycled water is treatment, blending with lower salinity water, and salinity source control. Each are discussed below.

Reverse osmosis (RO) treatment removes approximately 98% of aqueous salts and metal ions. Application of RO to a portion of tertiary effluent could reduce TDS, sodium, and chloride to acceptable concentrations. Any treatment process that involves RO results in production of a concentrate that can be disposed of via an ocean outfall. RO can be expensive from a capital and O&M perspective.

Recycled water could be blended with lower salinity water such as potable water or non-potable groundwater. The blend ratio is dependent on the salinity of each source, which varies. Use of potable water is not preferred since the intent of recycled water use is to offset potable water use. Non-potable groundwater is located near two potential recycled water customers, both far from the WWTPs and is assumed to continue to be served to those customers. Therefore, there is potential for blending for the individual customer but not for the recycled water system.

Salinity levels in wastewater are primarily influenced by the potable water supply sources, human excretion, types of waste discharges, water conservation practices, shallow saline groundwater infiltrating gravity sewer collection systems, and the use of water softeners. For example, the City of Santa Barbara has seen TDS in its recycled water drop from roughly 1,400 mg/L to roughly 1,000 mg/L since its ocean desalination plant has started delivering low TDS water to its potable system. However, MWD does not have much flexibility in its water supply sources so this is not a viable solution. Reducing salinity inputs to wastewater that can be managed, such as restricting water softener operation (e.g., requiring use of exchangeable canisters that can be discharged at an ocean outfall), are feasible but highly unpopular and therefore, are not considered.

Salinity in recycled water can be also be reduced at each customer site through treatment, blending with lower salinity water, or irrigating sensitive areas separately with existing water supply. Unless only a small number of customers requires additional treatment, individual treatment systems are not likely cost effective compared with centralized treatment at the water reclamation facility. Blending with lower salinity water requires a large tank or pond. Many golf

courses have water features that supply their irrigation system so recycled water could be blended with lower salinity water to lower overall irrigation water salinity. However, only Birnam Wood Golf Club has a water feature that could support this approach. Also, many golf courses have installed separate irrigation systems for their green as their course-wide irrigation systems are upgraded. This would allow a lower salinity water be applied to the greens and higher salinity recycled water applied to the remainder of the course. However, our understanding is that separate irrigation systems are not in place in the two golf courses included in the study.

Salinity impacts on turfgrass can also be managed with on-site mitigation measures, such as applying extra water to leach excess salts below the turfgrass root zone; providing adequate drainage; using soil amendments; modifying turf management practices; and modifying root zone mixture. The success of this approach highly depends upon specific turfgrass and other plant species tolerance combined with the local climate, soil drainage (internal) characteristics and sensitivity to sodium of the clay type contained in the native soil. This approach is likely to be used in combination with reducing the salinity content in recycled water to acceptable levels for each customer.

For the purposes of this study, the assumed approach to lower salinity for non-potable alternatives is RO treatment at the water reclamation facility. This study assumes a target concentration of 800 mg/L for turfgrass based on successful existing use of local groundwater for this purpose. The District is currently conducting additional groundwater quality testing to supplement the historical data. The target concentrations for each constituent will be dependent on customer needs and their ability to manage salinity. For example, some ornamental plants (trees & shrubs) could experience foliage burning at moderate concentrations of boron, sodium, chloride or TDS depending upon each species sensitivity. An SAR <5.0 is also desirable at TDS of 800 mg/l (electrical conductivity of water (EC_w) of 1.25 dS/m) to maintain reasonable infiltration / permeability rates based on the combined interaction of EC_w & SAR. Discussions with individual customers are necessary to establish final water quality targets and whether less costly alternatives to RO treatment are viable.

4.1.2 Agricultural Irrigation

Over 800 acres of irrigated agriculture were identified in the MWD service area. Agricultural irrigation demand can vary from 1.5 AFY to 3.0 AFY per acre of crops, depending on crop type, rotation, and cycles. Connecting agricultural irrigation customers is contingent upon their willingness to use recycled water. Similar to turfgrasses and plants, crops have specific water quality requirements that exceed public health-based water quality goals. Four common categories of water quality-related issues are (Ayers and Wescot 1985):

- Salinity: Salts in soil or water reduce water availability to the crop to such an extent that yield is affected.
- Water Infiltration Rate: Relatively high sodium or low calcium content of soil or water reduces the rate at which irrigation water enters soil to such an extent that sufficient water cannot be infiltrated to supply the crop adequately.
- Specific Ion Toxicity: Certain ions (sodium, chloride, or boron) from soil or water accumulate in a sensitive crop to concentrations high enough to cause crop damage and reduce yields.
- Miscellaneous: Excessive nutrients reduce yield or quality. Unsightly deposits on fruit or foliage reduce marketability. Excessive corrosion of equipment increases maintenance and repairs.

Water quality goals for crops are expected to be stricter than turfgrass based on other recycled water projects across California and the prevalence of sensitive crops in the Montecito area – citrus and avocados. A TDS target concentration of 450 mg/L is assumed based on typical sensitive crop water quality requirements; however, the water quality goals should be developed through customer participation and with consideration for crops and soil, among other factors. Therefore, further discussions with agricultural community members are necessary to establish their water constituent concerns.

As shown in Figure 13, the vast majority of the acreage is located a substantial distance from the recycled water sources (existing WWTPs). Due to the location of agricultural irrigation parcels, potentially stricter water quality requirements, and their current reliance on relatively inexpensive groundwater, the non-potable reuse market assessment focused on landscape irrigation. Agricultural irrigation parcels are considered for service in Chapter 5 where proximate to proposed conveyance facilities for potable reuse alternatives.

4.2 Groundwater Augmentation

In 2015, the Montecito Groundwater Basin Recharge Feasibility Study (Dudek 2015) was prepared under a partnership with Heal the Ocean, MWD, and MSD that evaluated the Montecito Basin for the feasibility of recharge with recycled water. The analysis was primarily based on the two previous hydrogeologic evaluations of the Montecito Basin - Safe Yield Evaluation of the Montecito Basin and Toro Canyon Area (Hoover 1980) and Hydrogeological Assessment Determination of Groundwater in Storage within the Montecito Water District (Slade 1991). The Dudek study concluded that there is a “limited opportunity to implement a groundwater recharge program with advanced treated recycled water in the Montecito Groundwater Basin” due to:

- Limited storage capacity even during periods of drought (Table 20) and seriously limited during periods of average or above average precipitation and
- High density of water supply wells, which makes meeting minimum travel times difficult.

Each of these issues is discussed further below.

Table 20: Available Storage Capacity during the 1991 Drought

Storage Unit	1991 Drought	
	Minimum (AF)	Maximum (AF)
Storage Unit 1	3,060	4,590
Storage Unit 2	290	732
Storage Unit 3	1,250	1,560
Toro Canyon Unit	350	420
Total	4,950	7,302

Source: Montecito Groundwater Basin Recharge Feasibility Study (Dudek 2015), Table 6.

Note: Refer to Figure 3 for storage unit designations.

4.2.1 Storage Capacity

The Dudek evaluation was based on data through 2014 and limited hydrogeological data was from the Hoover (1980) and Slade (1991) evaluations. Based on this information, the conclusions stand; however, increased groundwater pumping due to the recent drought and increased potable water prices have reduced groundwater levels to historic lows. An outstanding question at this time is whether groundwater pumping rates will continue under average or above average conditions and whether groundwater levels would recover as quickly as in the past due to a higher reliance on groundwater than in the past.

MWD efforts associated with SGMA compliance will evaluate long-term pumping estimates and the available long-term storage capacity should be considered as part of this evaluation. Available storage capacity may be increased in certain areas if pumping is increased to maintain lower groundwater levels. Ultimately, a groundwater recharge project will not likely be cost effective unless storage capacity is available in most or all years so addressing this issue is essential.

4.2.2 Travel Time

Subsurface travel time is roughly 100 feet per month based on calculating average groundwater velocity using the limited basin aquifer data. DDW regulations credit this analytical method with 0.25 months per 1.0 months of estimated travel time so a minimum travel time of 2 to 3 months requires the calculation to demonstrate at least 8 to 12 months. This translates to requiring a minimum distance of 800 to 1,200 feet from an injection well to a potable well.

MWD controls the only groundwater wells in the Birnam Wood and Ennisbrook developments and provide non-potable groundwater for irrigation at the Birnam Wood Golf Course. As a result, MWD could conceivably inject advanced treated recycled water within this area for capture by their existing wells or new wells and avoid the risk of encountering private potable wells within the developments. As shown in Figure 14, there are several locations in the Birnam Wood area that are greater than 800 ft from existing wells.

4.2.3 Conclusions

The Dudek (2015) study correctly concluded that groundwater recharge with advanced treated recycled water is not likely to be cost effective due to the lack of storage capacity during average and above precipitation periods combined with the high density of supply wells cause meeting minimum travel times to be difficult. However, increased groundwater pumping basin-wide and MWD's control of the Birnam Wood area may provide a project opportunity. Validating the groundwater recharge opportunity in the Birnam Wood area will require a focused hydrogeological evaluation that is beyond the scope of this study. Therefore, groundwater recharge in the Birnam Wood area is included as an alternative in this study but the supporting hydrogeological conditions must be confirmed to determine if a project is feasible.

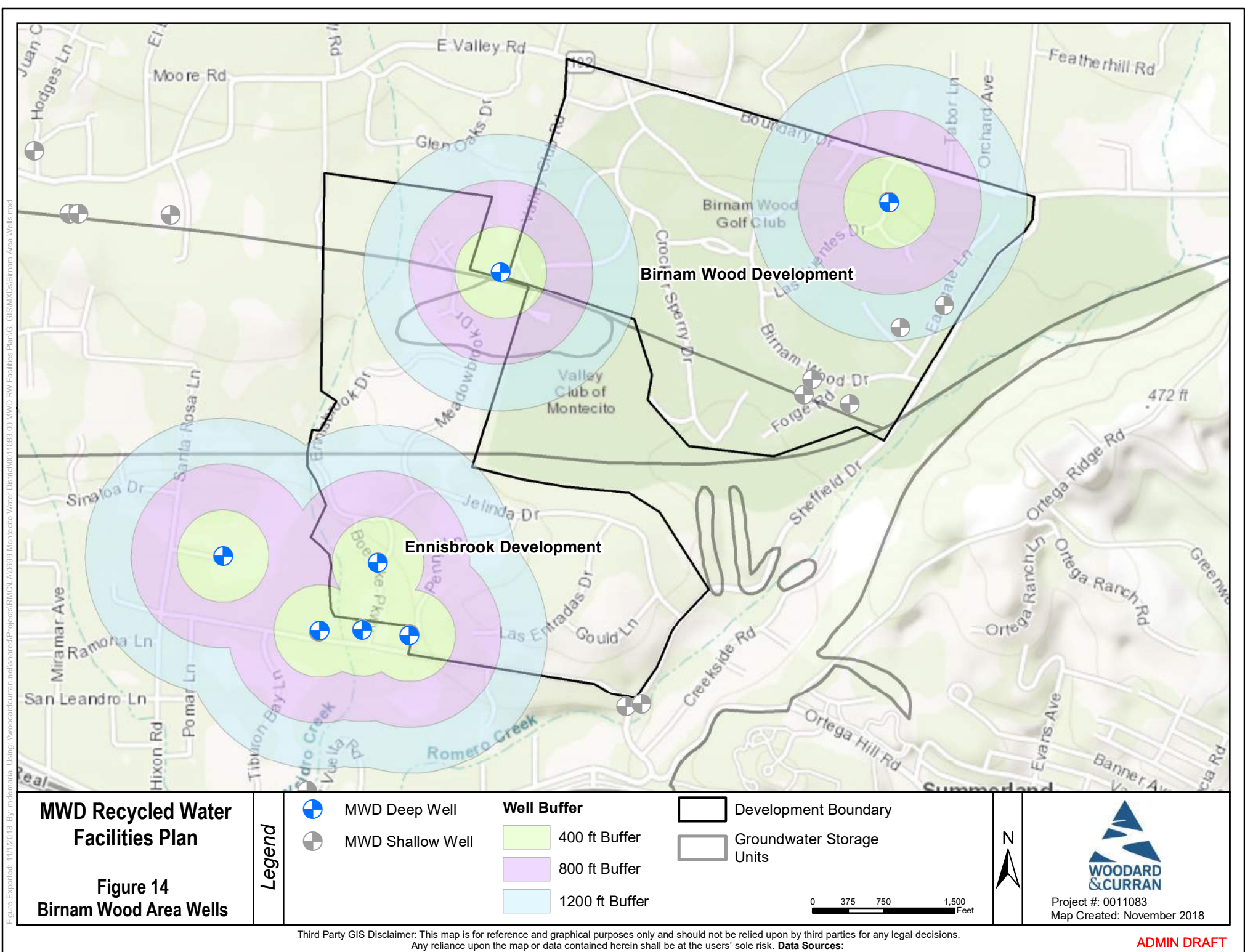

Figure Exported: 11/17/2018 By: mdeemalia Using: \\woodardcurran\ne\shared\Project\RM\CL\A\0659_Montecito Water District\0011083\00_MWD RW Facilities Plan\G. GIS\MXD\Birnam Area Wells.mxd

MWD Recycled Water Facilities Plan

**Figure 14
Birnam Wood Area Wells**

Legend	MWD Deep Well	Well Buffer	Development Boundary
	MWD Shallow Well	400 ft Buffer	Groundwater Storage Units
		800 ft Buffer	
		1200 ft Buffer	





Project #: 0011083
Map Created: November 2018

Third Party GIS Disclaimer: This map is for reference and graphical purposes only and should not be relied upon by third parties for any legal decisions. Any reliance upon the map or data contained herein shall be at the users' sole risk. **Data Sources:**

ADMIN DRAFT

5. ALTERNATIVES DEVELOPMENT & ANALYSIS

This plan considers three recycled water sources (Montecito Sanitary District (MSD), the City of Santa Barbara (City or SB), and Summerland Sanitary District (SSD) for non-potable reuse (NPR), indirect potable reuse (IPR), and direct potable reuse (DPR) opportunities at multiple project locations. In addition, a regional partnership with Carpinteria Valley Water District’s IPR project is included. The alternatives development and analysis follows a two-step evaluation process. First, a long list of “alternatives” (nearly 30) are defined (Section 5.2.2) for a comparative evaluation primarily based on unit cost (Section 5.2.2). The alternatives definition includes facilities, capacity, yield, and cost estimates. Then, a more detailed definition and evaluation of the top alternatives is conducted to select a preferred project (Section 6).

5.1 Recycled Water Supply Options

Three recycled water supplies are considered to meet the recycled water market opportunities described in Chapter 4. The level of treatment required to produce recycled water of sufficient quality varies depending on the end use. NPR alternatives require a minimum of tertiary filtration and disinfection. Filtration can occur via cloth disk filters, microfiltration (MF), or ultrafiltration (UF). In addition, MSD and SSD may require reverse osmosis (RO) to reduce salinity to acceptable levels. MF or UF is required for pre-treatment for RO.

In this setting, groundwater augmentation (GWA) alternatives are assumed to exclusively be injection, requiring advanced water treatment (AWT), which consists of UF, RO, and advanced oxidation process (AOP). Raw water augmentation (RWA) alternatives assume “AWT+”, which is defined in this report as AWT plus a redundant disinfection step. Treated drinking water augmentation (TDWA) assumes “AWT++”, which is defined in this report as “AWT+ Ozone/BAC.

Figure 15: Recycled Water Treatment Requirement Assumptions

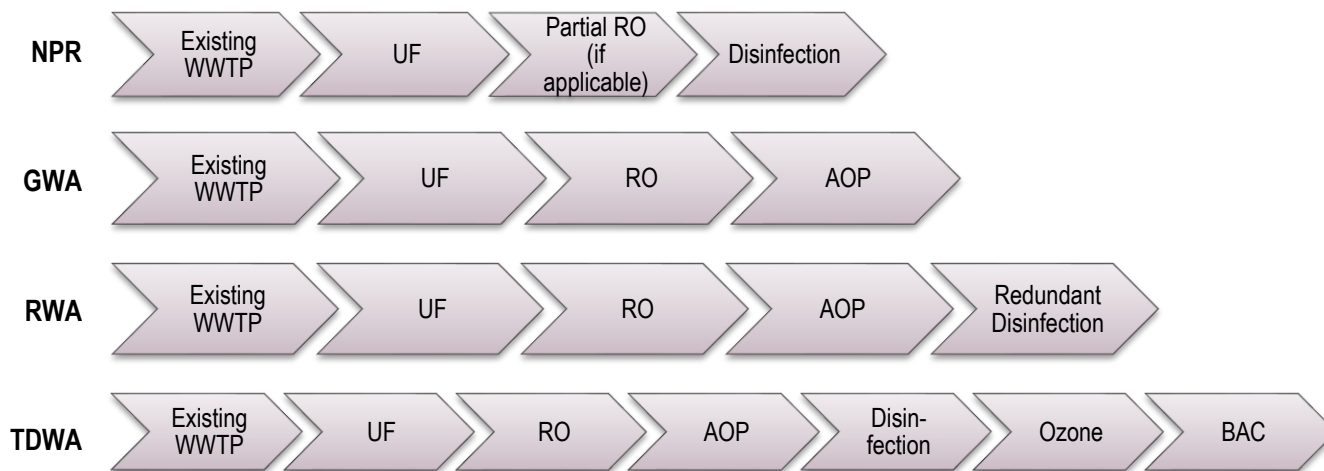

5.1.1 MSD WWTP Supply

Existing MSD WWTP flows are approximately 0.5 MGD and MSD estimates the need to maintain a minimum flow of 0.1 MGD to the ocean outfall. Therefore, available MSD flows could be as low as 0.4 MGD. However, MSD WWTP flows were averaging approximately 0.6 MGD prior to the wildfire and mudslides during the winter of 2017/2018. A maximum available flow of 0.6 MGD is assumed for maximum reuse based on anticipating a recovery of wastewater flows as visitor lodgings reopen and more residents return. Use of all MSD flows would result in low discharges during

portions of the year consisting exclusively of RO concentrate. Several Central Coast wastewater agencies currently have no discharge during the summer peak irrigation season since all recycled water is used; however, the minimum ocean outfall discharge, if any, specific to MSD must be determined to maximize use of available flows.

As noted in Section 4.1.1.1, a target TDS concentration of 800 mg/L in recycled water for NPR will require RO treatment. For MSD WWTP, roughly 50% of flow is assumed to be treated with RO to reduce TDS from 1,750 mg/L. To protect the RO membranes, MF or UF must be added upstream, therefore all recycled water flows would be treated with MF or UF and then a portion of that flow would be treated with RO. The RO product water would be combined with RO bypass water for disinfection.

IPR and DPR alternatives assume MSD WWTP effluent would be fed to an AWT facility (AWTF) after equalization. The AWTF is assumed to be located within the existing MSD WWTP site.

5.1.1.1 MSD WWTP Considerations

Increased reuse will reduce the volume and quality of effluent discharged to the ocean outfall and, under certain conditions, all effluent could be RO brine. Lower effluent flows and increased effluent density impacts the performance of the outfall since the outfall diffuser ports require a minimum velocity to be maintained to prevent sedimentation and ensure proper initial dilution. Also, minimum effluent velocities may be required to prevent sedimentation in outfall pipelines with shallow slopes.

Therefore, the potential impact of reduced effluent volumes and quality should be evaluated along with potential mitigation measures. The evaluation must consider that all WWTP effluent may be discharged at certain times while only RO brine may be discharged at other times. The evaluation requires consideration of multiple variables and scenarios that is beyond the scope of this effort but is recommended as a next step in Section 7.4.1.

MSD reviewed potential electrical loadings for alternatives under consideration and found that the existing breaker has sufficient capacity for the smaller yield alternatives but the larger yield alternatives would require further analysis. In all cases, a new electrical distribution board is needed.

5.1.1.2 Export of MSD Wastewater Flows

Export of raw MSD wastewater (before treatment at MSD WWTP) to either the City's WWTP or Carpinteria Sanitary District's (CSD) WWTP was investigated but is not considered further due to the lack of potential cost savings and institutional complexity. In this scenario, the MSD WWTP would be shut down and MSD would continue to manage the sewer collection system and export the raw wastewater through a new lift station and pipeline from MSD WWTP to the City WWTP or CSD WWTP. While storage at the CSD WWTP could mitigate peak wet weather flows, wet weather flows would still drive pipeline and pump station sizing. Also, the City and CSD would likely charge a capital fee to use WWTP facilities already funded by their ratepayers and would charge for ongoing O&M. Conveyance, capital fee, and O&M costs would likely offset the potential savings from shutting down the MSD WWTP and would require agreements between MWD, MSD, and the City or CSD.

5.1.2 SSD WWTP Supply

Existing SSD WWTP flows are approximately 0.1 MGD. Use of all SSD flows would result in low discharges during portions of the year consisting exclusively of RO concentrate. The minimum ocean outfall flow requirement for SSD is not known at this time, so the full 0.1 MGD flow is assumed to be available; however, this assumption should be confirmed if a project at SSD moves forward to determine the maximum available flow.

As noted in Section 4.1.1.1, a target TDS concentration of 800 mg/L in recycled water will require RO treatment. For SSD WWTP, roughly 30% of flow is assumed to be treated with RO to reduce TDS from 1,250 mg/L. Also, MF or UF

must be added upstream of RO so all recycled water flows will be treated with MF or UF and a portion of that flow will be treated with RO. The RO product water will be combined with RO bypass water for disinfection.

SSD has tertiary filters but disinfection is located upstream of the filters and does not have the process reliability features to meet recycled water requirements. Therefore, SSD would need additional facilities to produce recycled water meeting Title 22 standards for NPR. Also, tertiary filters are not sufficient upstream of RO so MF or UF is the assumed tertiary treatment technology.

IPR and DPR alternatives assume SSD WWTP effluent would be fed to an AWT facility (AWTF) after equalization. The AWTF is assumed to be located within the existing SSD WWTP site.

5.1.3 City of Santa Barbara

The City treats apportion of its secondary effluent to meet tertiary disinfected recycled water requirements. While the WWTP has 3.0 MGD capacity through its UF membranes, the existing tertiary treatment is not currently operating at its design capacity. However, the City expects to have it operating at full capacity by 2020, making the 3.0 MGD recycled water available. The City pumps the recycled water through their distribution system. For this scenario, MWD would take recycled water from the City's 14-inch pipe near the entrance to the Santa Barbara Zoo on Ninos Drive and convey the water to the vicinity of the MSD WWTP for distribution within MWD's service area (as shown on Figure 11).

NPR alternatives would not require any further treatment. IPR and DPR alternatives would require AWT. It may be possible to eliminate the MF/UF step of advanced water treatment as the City already employs UF as its tertiary filtration step; however, this assumption is dependent on the quality of the water after being conveyed through the distribution system and would need to be confirmed. An acceptable location for the AWTF must be determined.

Available supplies are dependent on unused tertiary effluent as well as capacity in the City's recycled water distribution system. Seasonal recycled water demand for existing City customers causes variation in available flows in summer and winter. As shown in Figure 16, available flows could be as low as 1.0 MGD during the summer and could approach 3.0 MGD in the winter. Project alternatives using City recycled water assume that the City deliveries occur throughout the day. If deliveries are limited to the daytime (when recycled water system capacity exists), additional storage would be required.

In addition to the tertiary flows, the City has approximately 3.0 MGD of secondary treated flows (as shown in Figure 16) that could be available for additional treatment and beneficial reuse. However, the flows may be reserved for a future City potable reuse project.

The City estimated a recycled water purchase price of \$2,600/AF based on previous recycled water wholesale agreements. The City did note that the price of recycled water should be lower with year-round use, such as with IPR, since the volume is higher and the City has sufficient spare conveyance capacity during the wet season.

Figure 16: Potential Recycled Water from the City of Santa Barbara

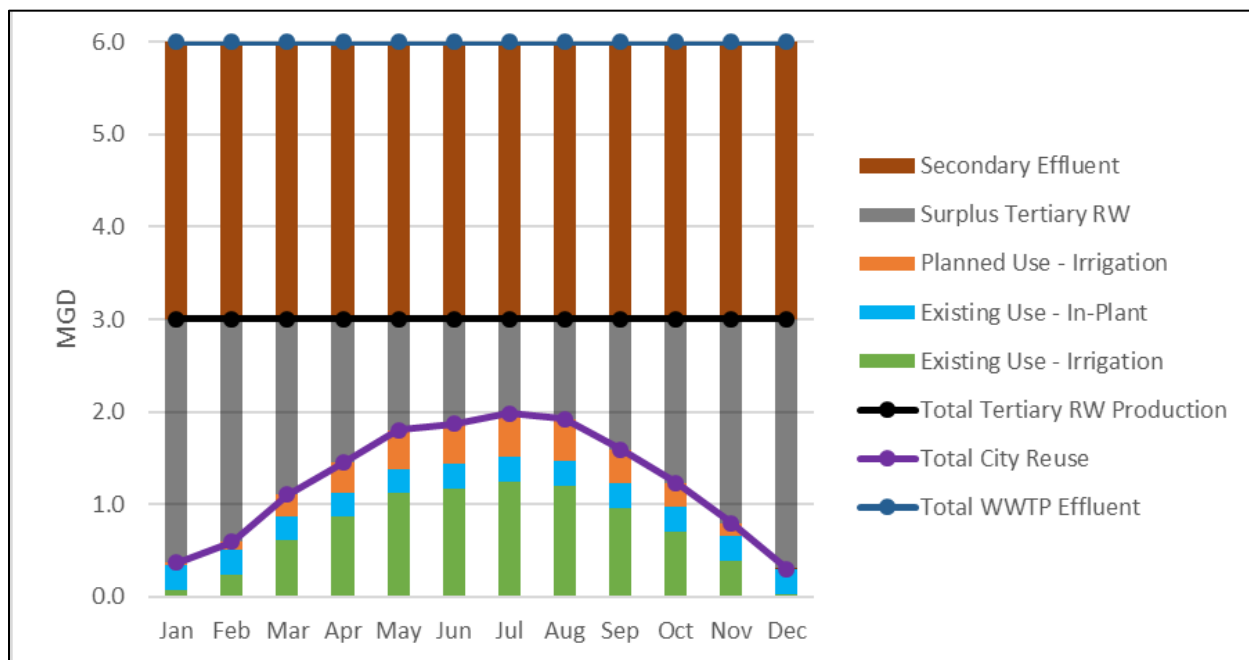

5.1.4 Summary of Recycled Water Supplies

The three recycled water supplies included in the alternatives are summarized in Table 21.

Table 21: Non-Potable Reuse Alternatives, Recycled Water Supplies

Source	Existing Treatment	Existing Flow	Available Flow	Existing TDS	Target Irrigation TDS
MSD	Secondary	0.5 MGD (560 AFY)	0.4 MGD (450 AFY) to 0.6 MGD (670 AFY)	1,500 mg/L ⁽¹⁾	800 mg/L ⁽²⁾
SSD	Secondary	0.1 MGD (110 AFY)	Up to 0.1 MGD (110 AFY)	1,200 mg/L ⁽¹⁾	800 mg/L ⁽²⁾
City	Tertiary	~3 MGD (3,360 AFY)	1 MGD (Summer) to 2.5 MGD (Winter) (2,000 AFY)	1,000 mg/L ⁽³⁾	Existing

Notes:

1. MSD and SSD effluent TDS concentrations were analyzed using method EPA Method 200.1 while MWD groundwater TDS concentrations, which are the basis for the target TDS, were reported using Standard Method 2540. The EPA method report TDS by Summation and tends to be 10% to 20% higher so the MSD and SSD TDS concentrations were reduced by 15% for comparison with the target TDS concentration.
2. Target based on existing groundwater TDS; partial RO included to reduce TDS concentrations to target
3. City values are from a sample collected on 10/9/2018 and are lower than historical values as a result of the City incorporating desalinated water into their water supply.

5.2 Recycled Water Alternatives Development

The cost effectiveness of a recycled water project is dependent on optimally sizing infrastructure and maximizing recycled water use. Design of a recycled water distribution system includes the following factors:

- WWTP equalization
- Recycled water treatment capacity
- Recycled water storage
- Pump station capacity
- Pipeline capacity
- Distribution system storage
- Seasonal and daily customer demand variations
- Customer delivery conditions (quality, pressure, flow)
- Customer onsite facilities (storage, treatment, pumps)

A challenge for recycled water irrigation projects is constructing infrastructure to deliver recycled water at a high level of service in a cost effective manner. Proper planning for successful reuse projects can anticipate these issues. The size of pipes, pumps, and tanks in recycled water systems are typically determined by peak flows. Pipes are typically sized for peak-hour flows, pump stations are sized for peak-hour or peak-day flows depending on system storage, and tanks are sized to meet peak-day flows. Peak hourly demands for irrigation can exceed nine times the annual average demand. This means the system may only operate at full capacity for short periods during the peak irrigation months and often results in facility capacity that remains unused for most of the year. The capital cost of a system sized for peak demand, combined with a small customer base, can result in very high recycled water unit costs. Therefore, balancing the cost of providing a robust recycled water system with providing an acceptable product to customers requires tradeoffs. Common tradeoffs to consider are reliability, peak season supplies, and peak hour deliveries.

Reliability

Interruptions in water service can have a significant financial impact on some large commercial or industrial customers. However, the majority of irrigation customers can continue to function properly if irrigation service is interrupted for a short time. Therefore, landscape irrigation and agricultural irrigation systems can tolerate lower levels of reliability – especially if the customer maintains a well onsite that can temporarily replace recycled water.

Peak Season Supplies

Large irrigation systems are typically limited by the ability of peak season recycled water supply to meet peak season demands. If the system is designed to meet peak demand with maximum available recycled water supply, then 50% of available recycled water is typically not reused due to seasonal irrigation demands. Supplementing the recycled water supply with an alternative source during peak periods can help increase reuse through the rest of the year by increasing the number of customers that can be served. One approach involves having some customers use existing water supplies, such as onsite wells, during peak demand periods so that the system does not need to be sized to meet peak demand. A simpler approach for the customer is to blend water at the recycled water pump station at the treatment plant. However, the system would still need to be sized to meet the peak hour demand.

An example of the benefit of incorporating supplemental water is shown in Figure 17 where the top figure is limited by the available supply during the peak month and the bottom figure uses supplemental water to allow for increased recycled water use during other months. In this example, 49 AFY of supplemental water allows for an additional 58 AFY of recycled water to be used. An application of this for MWD would be the Birnam Wood Golf Course using the non-potable groundwater as the supplemental water source.

Figure 17: Example Monthly Seasonal Irrigation Demand

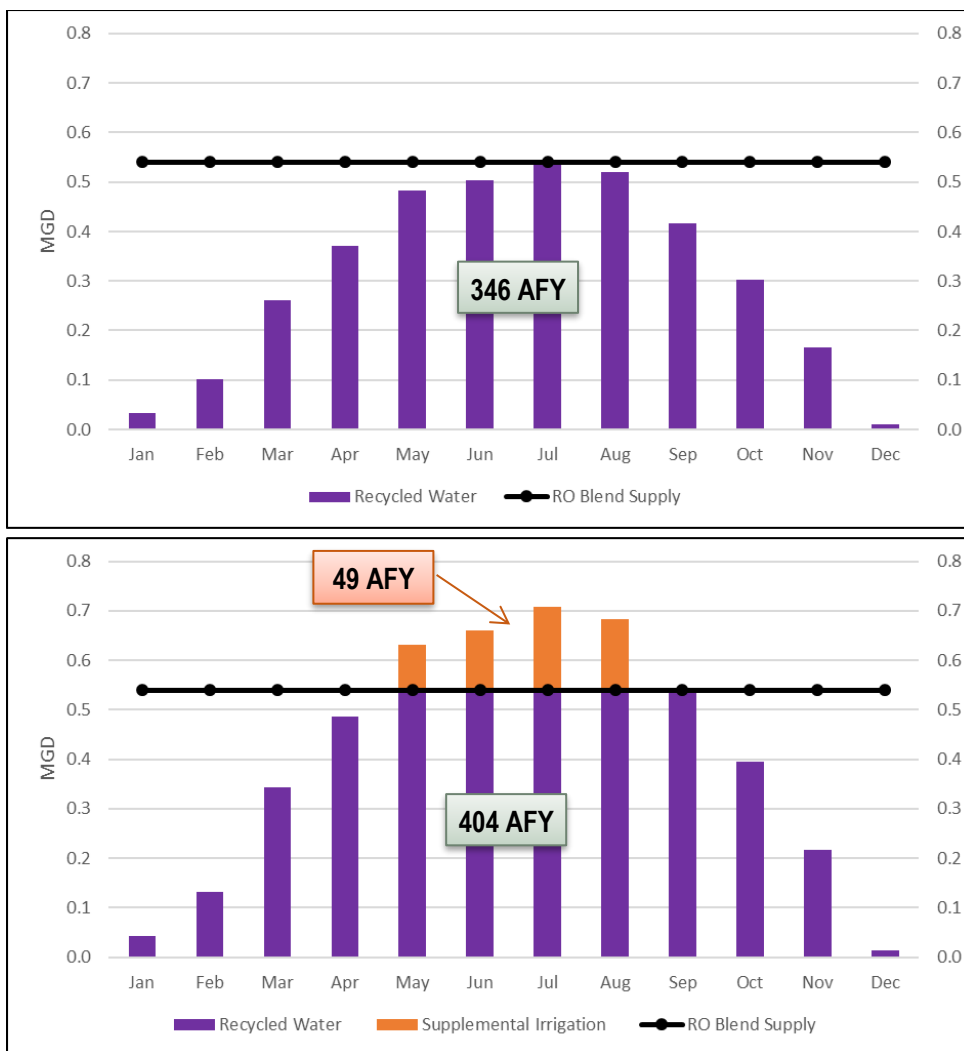

Peak Hour Deliveries

A critical factor in system performance relative to flow, pressure, and water quality is pipeline sizing. The recommended approach is to size pipelines for peak hour flows and adopt velocity criteria similar to water system design criteria. Water agencies commonly use this approach. Undersized pipelines can limit the capacity for future demand growth and increase energy costs as pipeline velocity and pressure losses approach design criteria. On the other hand, oversized pipelines can create water quality issues as water age exceeds the residual disinfection. As a result, implementation of NPR projects must balance the need to serve customers in the near-term under satisfactory water age conditions while allowing for future growth, despite the difficulty of predicting the prospects for system growth.

Facilities would be smaller if deliveries could occur over a 24-hour duration. Recycled water could be delivered to a water supply pond or directly into the local irrigation system. Spreading deliveries over 24 hours instead of 8 or 12 hours allows for smaller storage, pumps, and pipes, thus reducing project cost. This option depends on the availability of onsite ponds for onsite storage.

Customer Conversions

The cost to convert (also referred to as “retrofit”) existing sites to recycled water has a high variance depending on the age and complexity of the existing irrigation system, as well as on the availability of adequate records or staff knowledge of the onsite irrigation and potable water piping. Most existing irrigation customers have separate potable-water and irrigation meters.

The simplest conversion entails bringing the new recycled water supply to the existing irrigation meter. Older sites may have improperly connected potable water features, such as drinking fountains or bathrooms, to the irrigation system or may not have a separate irrigation meter. These sites must consider the cost to separate the non-potable (irrigation) system and potable systems, such as installing new potable lines to the drinking fountains or bathrooms. Also, recycled water irrigation systems must avoid spraying eating areas and drinking fountains, which may require re-routing of underground irrigation pipes or other measures.

5.2.1 Planning and Design Assumptions

Table 22 summarizes design criteria used to size infrastructure for the various alternatives.

Table 22: Facilities Criteria and Hydraulic Criteria

Item	Value / Notes
Wastewater Equalization	
Design Basis	Fully equalize diurnal curve
Treatment	
Capacity	Lesser of: Maximum day demand or Maximum supply available
Recycled Water Storage	
Design Basis – Alternatives	50% of Maximum day demand
Design Basis – Top Alternatives	Minimum for pump station or to meet hourly demand
Pump Stations	
Design Basis	Peak hour flow, head
Pump Efficiency	75%
Number of Pumps	Includes 1 standby
Pipelines	
Design Basis	Peak hour flow
Max Velocity for Sizing	5 ft per second
C Coefficient for Head loss	130 (assumes ductile iron pipe)
Max Head loss	5 ft per 1,000 ft
Customers	
Delivery Pressure – direct service	60
Delivery Pressure – to storage	10

Storage

The difference between diurnal WWTP influent variation and diurnal irrigation demand variation must be addressed so that sufficient supplies are available on an hourly basis. WWTP flows typically peak in the late morning, peak again in the evening, and decrease significantly overnight. In contrast, most landscape irrigation demand occurs at night due to regulatory restrictions regarding time of use. As a result, recycled water demands are at their highest when WWTP flows are at their lowest.

The most common way to address this issue is through wastewater equalization and/or recycled water storage. An hourly comparison of effluent produced and system demand should be prepared in order to properly size necessary recycled water storage. Wastewater equalization is assumed for MSD and SSD supply alternatives and recycled water storage is included for all alternatives. Figure 18 is a representative diurnal flow for MSD WWTP for July 2018. In this example, an equalization tank with 100,000 gallons of capacity could store the excess effluent during the day (above 0.5 MGD) and use this supply during the evening when flows drop below 0.5 MGD.

Figure 18: MSD WWTP Diurnal Flow, Average for July 1 to July 31, 2018

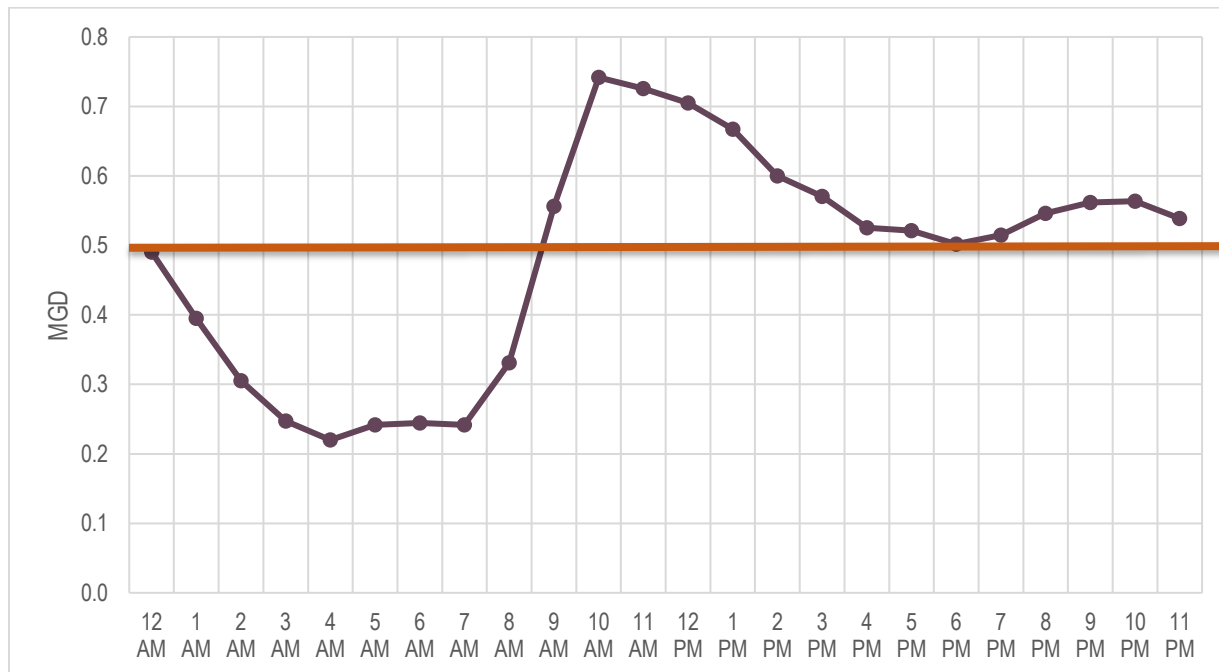

Source: Montecito Sanitary District

5.2.2 Alternatives Cost Estimate Basis

Cost estimates were developed to evaluate and compare the different project alternatives and to support the selection of a recommended alternative. The actual final costs of the project will depend on a variety of factors, including but not limited to actual labor costs, material costs, site conditions, market conditions, project scope, and implementation schedule.

5.2.2.1 Capital Cost Basis

Capital cost estimates were based on similar recycled water projects, cost quotations from suppliers, and industry publications. As the Facilities Plan is a preliminary planning phase project, the provided estimates are considered Class 5 estimates based on the International (ACEI) Recommended Practice No. 56R-08, Cost Estimate Classification System – As Applied for the Building and General Construction Industries (revised December 2012). Class 5 estimates are based on a level of project definition of 0 to 2 percent and are suitable for alternatives analysis. The typical accuracy ranges for a Class 5 estimate is -20 to -50 percent on the low end, and +30 to +100 percent on the high end. In addition, the capital costs include the following contingency and markups:

- Construction Contingency: 25% of raw construction costs to account for unknown or unforeseen construction costs.

- Implementation Allowance: For non-potable reuse projects, 25% of construction costs for environmental documentation, permits, design, financing, construction management, and engineering services during construction. An additional 5% of construction costs for potable reuse projects for additional permitting and technical analysis.

Estimated costs are referenced to the September 2018 Engineering Construction Cost Index (ENR CCI) for Los Angeles 12002.5.

5.2.2.2 Unit Costs and Assumptions

Table 23 presents the construction and O&M costs for recycled water system facilities.

Table 23: Alternatives, Unit Cost Assumptions

Facilities	Construction Cost ⁽¹⁾	Notes	O&M Cost
Electricity	--		\$0.18/kWh
Water Reclamation Facilities			
Tertiary Only	= 725,570 * Q ^{0.5862}	Q = Capacity (MGD); Note 2	8% of capital cost
MF/UF Membranes	\$2.7M per MGD	Note 2	8% of capital cost
RO Membranes	\$4.1M per MGD	Note 2	8% of capital cost
UV Disinfection	\$0.46M per MGD	Note 2	8% of capital cost
UV-AOP	\$3.3M per MGD	Note 2	8% of capital cost
Ozone	\$4.4M per MGD	Note 2	8% of capital cost
Monitoring Equipment – RWA	10% of Treatment Costs		\$250,000 per year
Monitoring Equipment – GWA	N/A		\$100,000 per year
Monitoring Equipment – TDWA	20% of Treatment Costs		\$500,000 per year
Distribution System Facilities			
Product Water Pump Station ⁽²⁾	\$6,500 / hp	Based on peak flow	5% of capital cost
Storage Tank	\$1.5 / gal		2% of capital cost
Pipelines	\$20 per in-dia per LF		1% of capital cost
Minor Crossing (Railroad, Creek)	\$250,000	In addition to pipe cost	1% of capital cost
Major Crossing (Highway)	\$750,000	In addition to pipe cost	1% of capital cost
Customer / Recharge Facilities			
Customer Retrofit	\$25,000/ea		
Monitoring Wells	\$250,000/ea		5% of capital cost
Injection Well (100 GPM)	\$1.0 M/ea		5% of capital cost
Injection Well (350 GPM)	\$1.5 M/ea		5% of capital cost
Groundwater Pumping			\$50 / AF
City of Santa Barbara Recycled Water Purchase			\$2,600 per AF

Notes:

1. Contingencies and factors presented in the previous section are added to the unit construction costs.
2. Source: WaterReuse Equivalency of Advanced Treatment Trains for Potable Reuse (Trussell, 2015)
3. Pump station sized based on 75% pump / motor efficiency.

5.2.2.3 Capital Financing Assumptions

The SWRCB Clean Water State Revolving Fund (CWSRF) offers low interest financing for publicly-owned facilities including recycled water projects. The CWSRF program offers 30-year financing at an interest rate of half the most

recent General Obligation Bond rate at time of funding approval. The interest rate has typically ranged from 1.5 percent to 3.0 percent and is currently 1.8%. CWSRF financing assumptions used to annualize capital costs are:

- Annual Interest Rate: 2.0%
- Term of Financing: 30 years

The rates for CWSRF financing are adjusted in January every year and change based on the current market conditions, so actual project financing rate will likely differ from the assumption above.

5.3 Alternatives Definition

Groups of NPR, IPR, and DPR alternatives were developed for comparative evaluation to select the top alternatives primarily based on unit cost. The alternatives definition includes facilities, capacity, yield, and cost estimates. A more detailed definition and evaluation of the top alternatives is conducted to select a preferred project (Section 5.5).

The objective of the alternatives analysis is to identify top alternatives for refinement and then perform a more detailed evaluation to ultimately select a preferred project (or set of projects). Key decisions to be made include:

- How much new supply is needed and what are the benefits of different project sizes? (The MWD UWMP identifies a recycled water goal of 1,000 AFY by 2025)
- Determine the preferred source of recycled water for NPR and/or IPR?
- What decisions can be made based on available information for IPR and how should MWD plan for hydrogeological investigations to support future decisions?
- Regional Projects: What is the value of projects outside of the MWD service area that require water exchanges to receive the water supply benefit and require partnerships with other agencies?
- Should both local and regional projects be pursued?
- Is the recommendation for a single project or multi-project program?

Table 24 summarizes the alternatives and they are presented on Figure 19 to Figure 21.

Table 24: Recycled Water Alternatives Summary Matrix

Type of Reuse	Level of Treatment	Source of Recycled Water		
		MSD	City	SSD
NPR (Irrigation)	Tertiary & Partial RO	NPR MSD1, MSD2, MSD3, MSD3a, MSD3b, MSD3c	NPR SB1, SB2, SB3	NPR SSD1, SSD2
IPR, Montecito Basin	AWT	IPR MSD1	IPR SB1a, SB1b	
IPR, Toro Canyon Sub-basin	AWT	IPR MSD2		IPR SSD2
IPR, Carpinteria Basin	AWT	IPR MSD3a, MSD3b		
IPR & NPR Combo	AWT	IPR MSD1 & NPR MSD3		
DPR	AWT+ or AWT++	DPR 1, 2, 3		
Regional Partnerships				
IPR, Carpinteria	AWT	IPR 4: Carpinteria IPR Project (Recycled Water Source: CSD)		
DPR, City	AWT+	DPR 4: City DPR Project (Recycled Water Source: City)		

Tertiary Filtration via sand filters, cloth filters, microfiltration (MF), ultrafiltration (UF), or other approved technology

AWT Advanced water treatment = UF, reverse osmosis (RO), and advanced oxidation process (AOP).

AWT+ AWT plus a redundant disinfection step.

AWT++ AWT+ plus ozone and biologically active carbon (BAC).

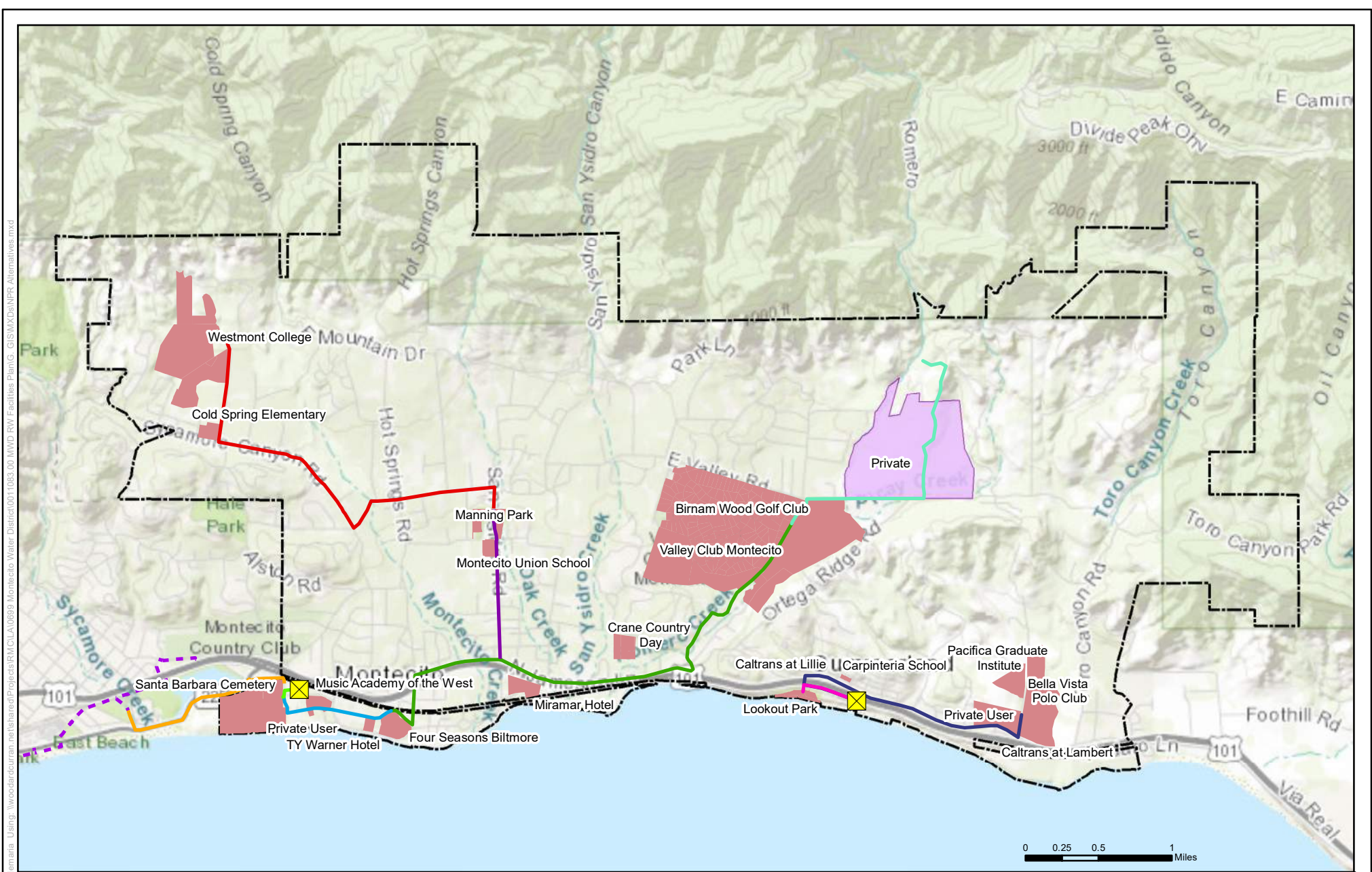

Figure Exported: 10/31/2018 By: mdemania Using: \\woodardcurran.net\shared\Projects\RM\CLAU0699\Montecito Water District\0011083_00 MWD RW Facilities Plan\GIS\MSX\NPR Alternatives.mxd

MWD Recycled Water Facilities Plan
Figure 19
Non Potable Reuse Alternatives

Legend	
	NPR MSD1 & SB1
	NPR MSD2 & SB2
	NPR MSD3 & SB3
	NPR MSD3a
	NPR MSD3b
	NPR MSD3c
	NPR SSD1
	NPR SSD2
	NPR SB1 & SB2 & SB3
	Landscape Irrigation Use
	Agricultural Irrigation Use
	WWTP
	City of Santa Barbara Recycled Water
	Montecito Water District

Project #: 0011083
 Map Created: November 2018

Third Party GIS Disclaimer: This map is for reference and graphical purposes only and should not be relied upon by third parties for any legal decisions. Any reliance upon the map or data contained herein shall be at the users' sole risk. **Data Sources:**

ADMIN DRAFT

Figure Exported: 10/31/2018 By: mdemania Using: \\woodardcurran.net\shared\Projects\RM\CL\A\0695\Montecito Water District\011083_00_MWD RW Facilities Plan\GIS\MapDocs\IPR Alternatives.mxd

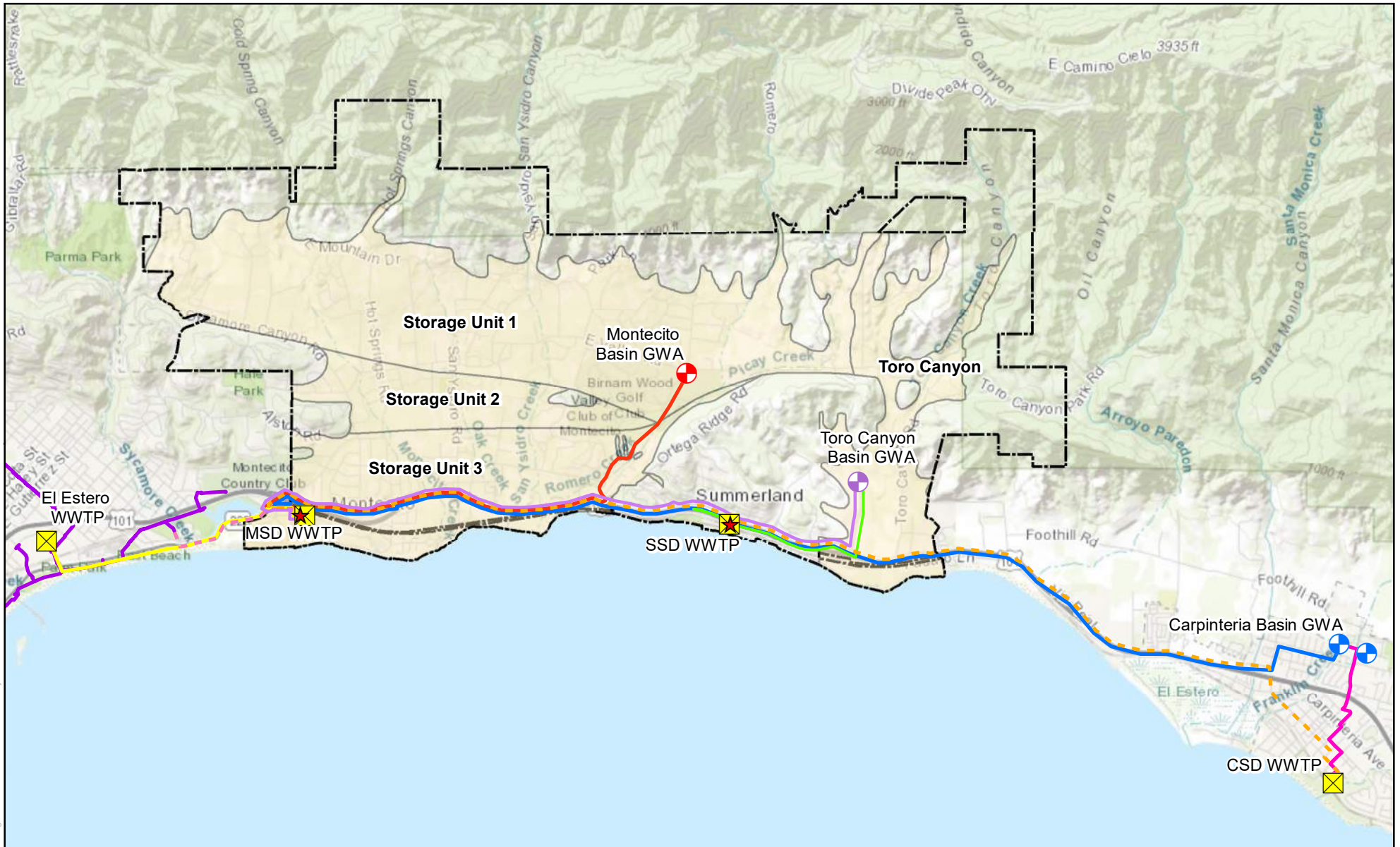

**MWD Recycled Water
Facilities Plan
Figure 20
Indirect Potable
Reuse Alternatives**

Legend

- ★ Proposed AWTF
- ☒ WWTP
- ⊕ Montecito Basin GWA
- ⊖ Toro Canyon Basin GWA
- ⊕ Carpinteria Basin GWA
- ↗ IPR MSD1 & SB1
- ⋯ IPR SB1a
- ↘ IPR SB1b
- ↖ IPR MSD2
- ↗ IPR MSD3a
- ↘ IPR MSD3b
- ↖ IPR SSD2
- ↗ IPR 4
- ↖ City of Santa Barbara Recycled Water
- Groundwater Storage Units
- ⋯ Montecito Water District

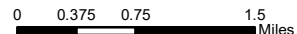

Project #: 0011083
Map Created: November 2018

Third Party GIS Disclaimer: This map is for reference and graphical purposes only and should not be relied upon by third parties for any legal decisions. Any reliance upon the map or data contained herein shall be at the users' sole risk. **Data Sources:**

ADMIN DRAFT

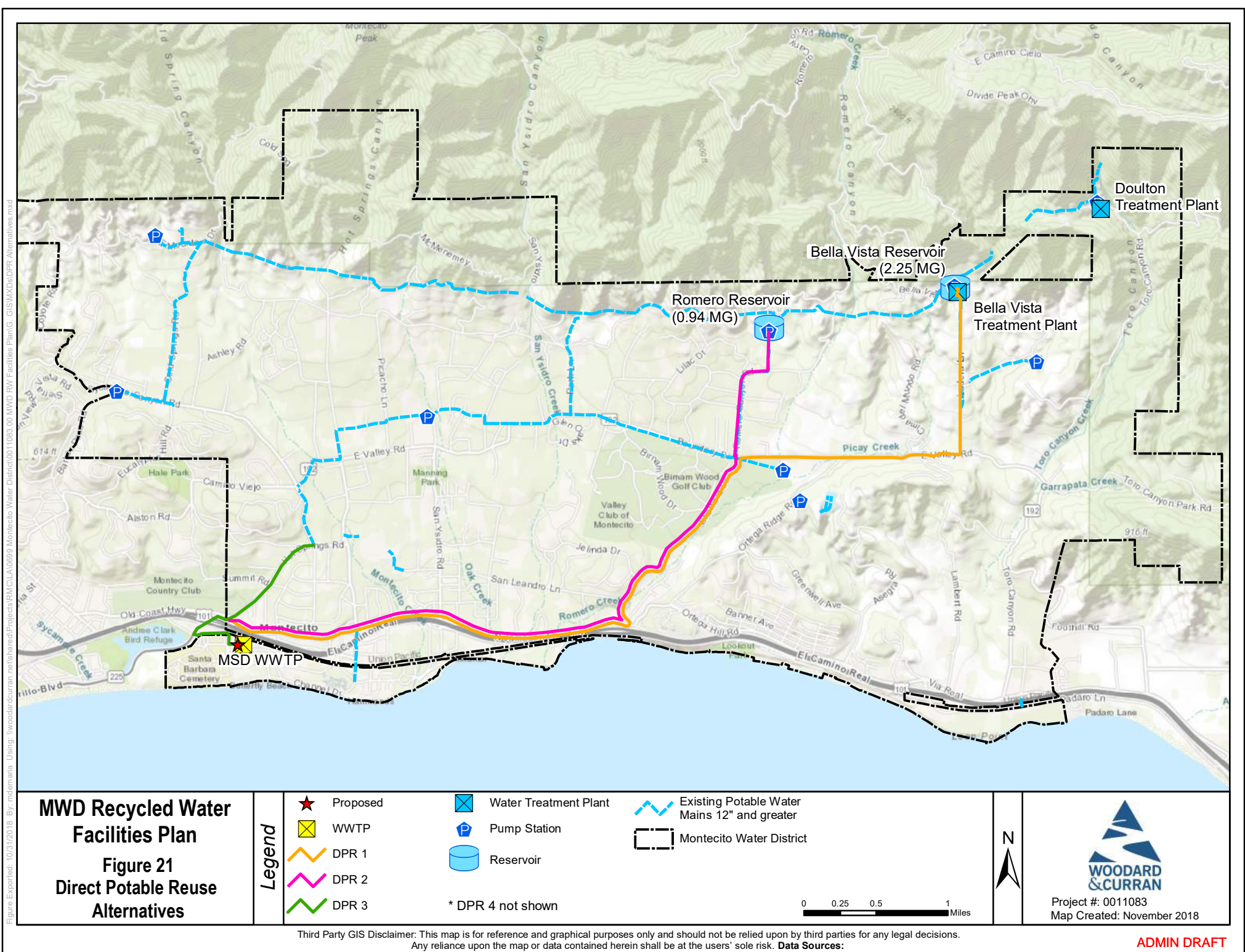
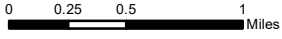

Figure Exported: 10/31/2018 By: mdemania Using: \\woodardcurran.net\shared\Projects\RM\CL\A\0695\Montecito Water District\011083_00 MWD RW Facilities Plan\G_GIS\MXDs\DPR Alternatives.mxd

MWD Recycled Water Facilities Plan
Figure 21
Direct Potable Reuse Alternatives

Legend	Proposed	Water Treatment Plant	Existing Potable Water Mains 12" and greater
	WWTP	Pump Station	Montecito Water District
	DPR 1	Reservoir	
	DPR 2		
	DPR 3		

* DPR 4 not shown



Project #: 0011083
 Map Created: November 2018

Third Party GIS Disclaimer: This map is for reference and graphical purposes only and should not be relied upon by third parties for any legal decisions. Any reliance upon the map or data contained herein shall be at the users' sole risk. **Data Sources:**

ADMIN DRAFT

5.3.1 Non-Potable Reuse Alternatives

Eleven NPR alternatives (Table 25, Figure 19) were defined to serve the largest non-potable customers (identified in Section 4) and serve other non-potable customers along the pipeline route. customers associated with each alternative are summarized in Table 26. RO treatment to reduce salinity is assumed for MSD and SSD supplies based on the analysis in Section 4.1.1.1.

Table 25: NPR Alternatives, Summary

Project	Additional Treatment Required	Treatment Capacity (MGD)	Pipe Diameter & Length	No. of Customers	Yield (AFY)
MSD					
NPR MSD1: Santa Barbara Cemetery	UF + 50% RO ⁽¹⁾	0.14	8" @ 700 ft	1	80
NPR MSD2: NPR 1 to Biltmore	UF + 50% RO ⁽¹⁾	0.20	10" @ 700 ft 6" @ 3,700 ft	5	112 ⁽²⁾
NPR MSD3: NPR 2 to Golf Courses	UF + 50% RO ⁽¹⁾	0.54	12" @ 21,000 ft	8	367 ⁽²⁾
<i>NPR MSD3 Extensions</i>					
NPR MSD3a: MSD3 to Manning Park	UF + 50% RO ⁽¹⁾	0.54	12" @ 21,000 ft 6" @ 4,500 ft	10	371
NPR MSD3b: MSD3 to Westmont	UF + 50% RO ⁽¹⁾	0.54	12" @ 21,000 ft 6" @ 23,100 ft	12	390
NPR MSD3c: MSD3 to Agriculture	UF + 50% RO ⁽¹⁾	0.54	12" @ 21,000 ft 6" @ 9,400 ft	9	404
City of Santa Barbara ⁽³⁾					
NPR SB1: Santa Barbara Cemetery	N/A ⁽⁴⁾	N/A	8" @ 6,900 ft	1	80
NPR SB2: NPR 1 to Biltmore	N/A ⁽⁴⁾	N/A	10" @ 6,900 ft 6" @ 3,700 ft	5	112 ⁽²⁾
NPR SB3: NPR 2 to Golf Courses	N/A ⁽⁴⁾	N/A	12" @ 27,200 ft	8	367 ⁽²⁾
SSD					
NPR SSD1: Local Irrigation	UF + 35% RO ⁽¹⁾	0.01	6" @ 2,200 ft	1	4
NPR SSD2: Max Irrigation	UF + 35% RO ⁽¹⁾	0.10	6" @ 9,700	4	70 ⁽²⁾

Notes:

1. Target TDS concentrations for recycled water is 800 mg/L to match existing groundwater supplies. MSD and SSD effluent require partial RO to reduce TDS concentration to roughly 800 mg/L.
2. Includes demands that are included in upstream alternatives. For example, NPR MSD2 includes NPR MSD1 demands.
3. Santa Barbara alternatives SB1, SB2, and SB3 serve the same customers as MSD1, MSD2, and MSD3, respectively.
4. Santa Barbara recycled water uses UF for tertiary filtration and has a TDS concentration of roughly 1,000 mg/L.

Figure 22: NPR Alternatives, System Schematics

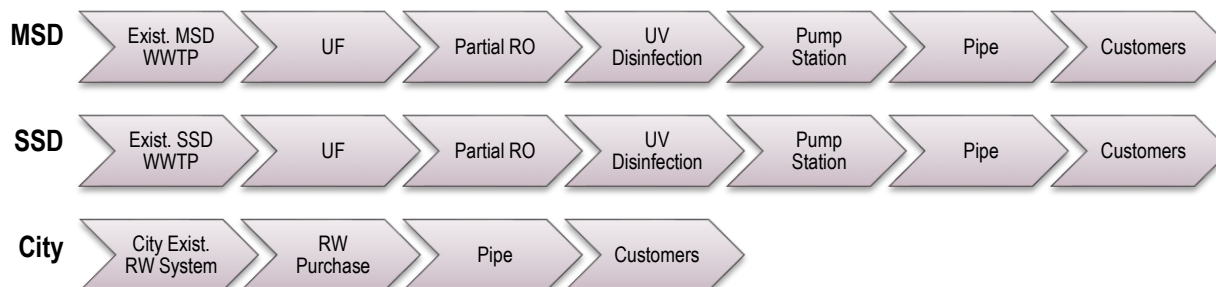

Table 26: NPR Alternatives, Potential Recycled Water Customers

Customer	Irrigation Demand Estimate ⁽¹⁾		Recycled Water Use Estimate ⁽²⁾	
	Average Annual (AFY)	Max Day (MGD)	Average Annual (AFY)	Max Day (MGD)
MSD1 / SB1	80	0.14	80	0.14
Santa Barbara Cemetery	80	0.14		
MSD2 / SB2	112	0.20	112	0.20
MSD1 / SB1	80	0.14		
Music Academy of West	2	0.004		
Four Seasons Biltmore	15	0.03		
Ty Warner Hotels	6	0.01		
Private Residence	9	0.02		
MSD3 / SB3	373	0.67	367	0.54
MSD2 / SB2	112	0.20		
Birnam Wood Golf Club	100	0.18		
Valley Club Montecito	150	0.27		
Miramar Hotel	11	0.02		
MSD3a / SB3a	381	0.68	371	0.54
MSD3 / SB3	373	0.67		
Manning Park	6	0.01		
Montecito School	2	0.003		
MSD3b / SB3b	420	0.75	390	0.54
MSD3a / SB3a	381	0.68		
Westmont College	30	0.05		
Cold Spring ES	9	0.02		
MSD3c / SB3c	453	0.81	404	0.54
MSD3 / SB3	373	0.67		
Private Agriculture	80	0.14		
SSD1	4	0.01	4	0.01
Lookout Park	4	0.01		
SSD2	84	0.15	70	0.10
SSD1	4	0.01		
Carpinteria School	0.1	0.00		
Private Residence	30	0.05		
Bella Vista Polo Club	50	0.09		

Notes:

1. Refer to Appendix A for additional demand information.
2. Actual demand served from MSD is limited by the available recycled water – estimated as 0.54 MGD – so only a portion of potential irrigation demand will be met with recycled water. Refer to Figure 17, which demonstrates this concept. For comparison purposes, City alternatives are assumed to be limited to this volume too.

5.3.1.1 NPR Alternatives Evaluation

Capital, operating, and unit costs were developed for each alternative applying the criteria described in Section 5.2.2. The capital costs are shown in Figure 23 and unit costs are shown in Figure 24. Detailed cost estimates are included in Appendix B.

Figure 23: NPR Alternatives, Capital Costs (\$M)

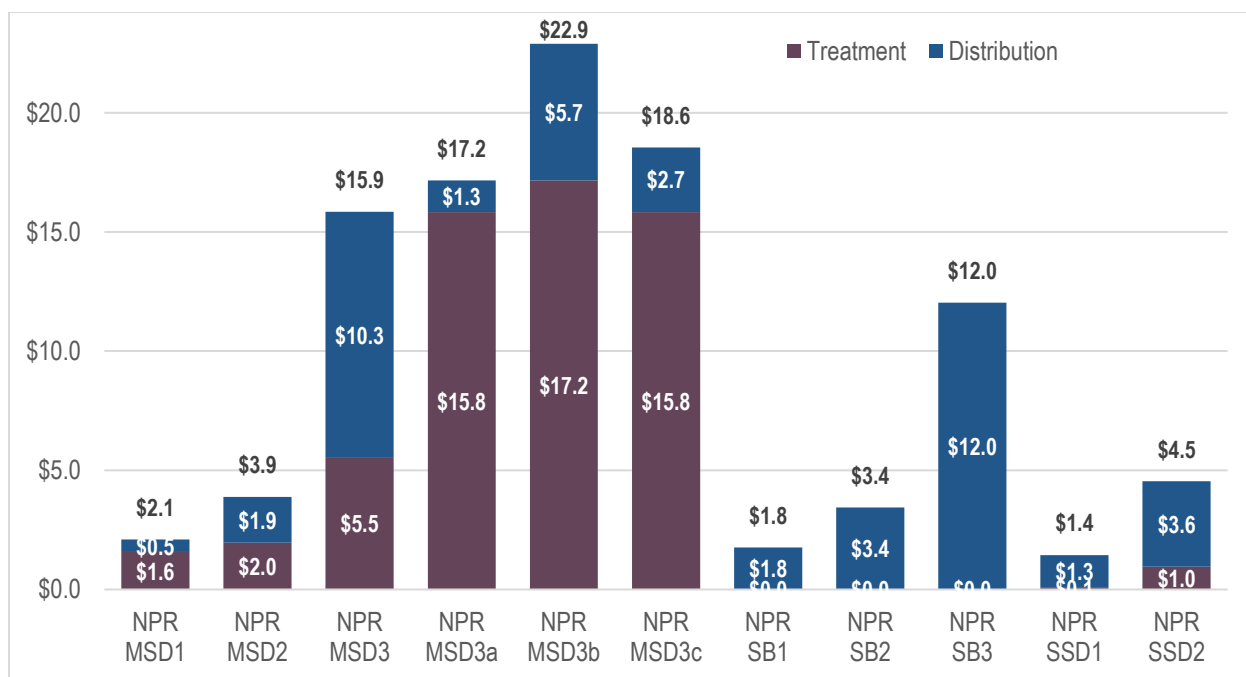

Note: Recycled water purchase price for City (SB) options are not included in this figure.

Figure 24: NPR Alternatives, Unit Costs (\$/AF)

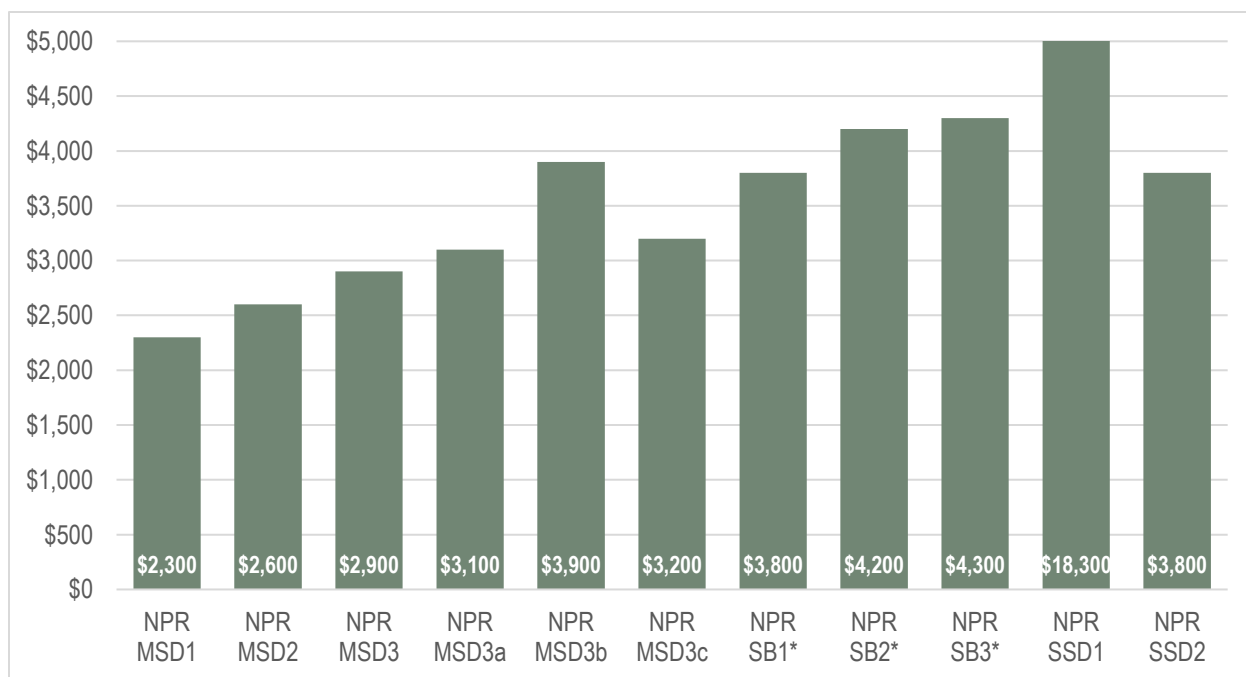

Note: Unit costs include annual O&M and annualized capital cost assuming SRF financing of 2.0% interest rate over 30 years.

* Includes City (SB) recycled water purchase price of \$2,600/AF.

The following conclusions were made based on comparing the cost estimates:

- MSD options have the lowest unit costs.
- MSD options are lower cost to serve the same customers as the City options. Therefore, MSD options are preferred over City options unless the City's RW purchase costs are reduced by 40 to 50 percent.
- SSD options are higher cost than MSD options. In addition, the SSD total recycled water production is approximately 20 percent of MSD's production. Therefore, MSD options are prioritized over SSD options. Although, both MSD and SSD options could be implemented in parallel.
- The options that include customers with large demands (MSD1, MSD 3, and SSD2) are preferred over those with many customers with small demands (MSD2) because the risk of not connecting increases with the number of customers.
- MSD3a and 3c costs are slightly higher than MSD3 and should be considered if sufficient supply is available and customers are interested.

Based on these conclusions, NPR MSD1 and MSD3 are recommended for further consideration as top alternatives. NPR SSD2 should be considered as a second tier NPR alternative and MSD3 3a and 3c should also be considered if sufficient supply is available. The NPR alternatives with findings are summarized in Table 27.

Table 27: NPR Alternatives, Cost Summary

Alternative	Yield (AFY)	Total Capital Cost	Unit Cost (\$/AF) ⁽¹⁾	Finding
MSD				
NPR MSD1	80	\$2,100,000	\$2,300	Top
NPR MSD2	112	\$3,880,000	\$2,600	Second Tier
NPR MSD3	367	\$15,850,000	\$2,900	Top
<i>NPR MSD3 Extensions</i>				
NPR MSD3a	371	\$17,160,000	\$3,100	Second Tier
NPR MSD3b	390	\$22,890,000	\$3,900	Screened
NPR MSD3c	404	\$18,550,000	\$3,200	Second Tier
City of Santa Barbara				
NPR SB1	80	\$1,760,000	\$3,800 ⁽²⁾	Screened Out
NPR SB2	112	\$3,440,000	\$4,200 ⁽²⁾	Screened Out
NPR SB3	367	\$12,040,000	\$4,300 ⁽²⁾	Screened Out
SSD				
NPR SSD1	4	\$1,440,000	\$18,300	Screened Out
NPR SSD2	70	\$4,540,000	\$3,800	Second Tier

Notes:

1. Includes annual O&M and annualized capital cost assuming SRF financing of 2.0% interest rate over 30 years.
2. City alternatives include \$2,600/AF purchase price.

5.3.2 Indirect Potable Reuse (Groundwater Augmentation) Alternatives

Ten IPR alternatives were defined (Table 28, Figure 20) for groundwater augmentation of the Montecito, Toro Canyon, and Carpinteria basins. As shown in Figure 25 each alternative applies advanced water treatment (AWT) for injection.

The IPR alternatives were defined based on maximizing available recycled water supplies. As a result, yield for MSD options was 540 AFY (0.5 MGD) assuming 0.60 MGD secondary effluent and accounting for RO losses and system downtime. Similarly, SSD options yielded 90 AFY (0.08 MGD) with 0.10 MGD input. City alternatives targeted 1,100 AFY (1.0 MGD) since the volume was available consistently throughout the year.

Alternatives carried forward for further consideration must conduct hydrogeological study to confirm capacity to store water in the basin and ability to meet minimum travel time. Also, the location of private wells will need to be confirmed and the implications of SGMA implementation on groundwater basin management will need to be considered.

Table 28: IPR Alternatives, Summary

Project	Source	AWT Location	Treatment Capacity	Pipe Diameter & Length	Yield (AFY)
IPR1: Injection in Montecito Basin					
IPR MSD1	MSD	MSD	0.5 MGD	8" @ 22,500 ft	540
IPR MSD1 + NPR MSD3 Combo	MSD	MSD	0.5 MGD	12" @ 21,000 ft	550
IPR SB1a	City RW	TBD	1.0 MGD	16" @ 6,200 ft 12" @ 22,500 ft	1,100
IPR SB1b	City WW	TBD	1.0 MGD	16" @ 11,800 ft 12" @ 22,500 ft	1,100
IPR MSD/SB1	MSD & City RW	MSD	1.0 MGD	12" @ 6,200 ft 12" @ 22,500 ft	1,100
IPR2: Injection in Toro Canyon Sub-basin					
IPR MSD2	MSD	MSD	0.5 MGD	8" @ 28,600 ft	540
IPR SSD2	SSD	SSD	0.08 MGD	6" @ 11,500 ft	90
IPR3: Injection in Carpinteria Basin					
IPR MSD3a (MSD AWTF)	MSD	MSD	0.5 MGD	8" @ 46,400 ft	540
IPR MSD3b (MSD WW to CSD AWTF)	MSD	CSD		10" @ 48,600 ft	540
IPR4: Regional Partnership					
IPR4: Carpinteria IPR Project Partnership	CSD	CSD	1.0 MGD	12" @ 7,400 ft 10" @ 1,000 ft	540

Figure 25: Indirect Potable Reuse Alternatives, System Schematics

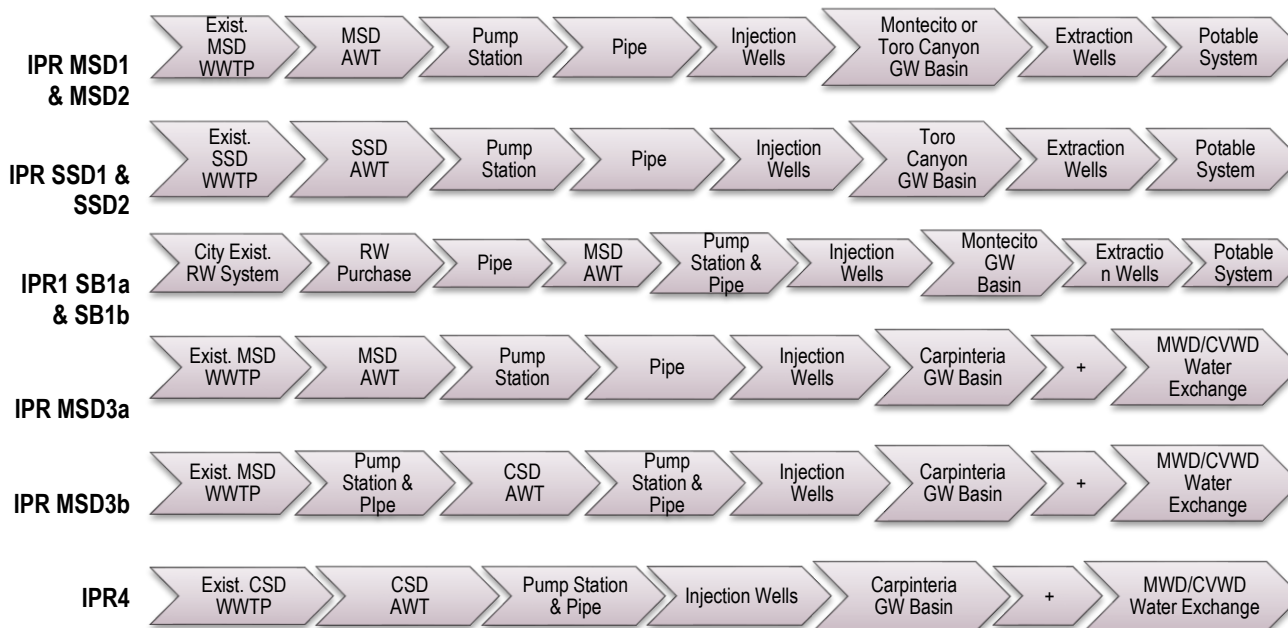

Additional City alternatives were identified that would maximize the available recycled water, however the costs were much higher because the system facilities (AWT, conveyance, etc.) would need to be sized for peak available flows. The higher City supply volume is only available for a portion of the year so much of the capacity is not used for large parts of the year, therefore these alternatives were not considered further. Also, an IPR alternative that maximizes all available wastewater from the City (roughly 4,300 AFY) for injection was suggested but was not included due to the number of injection wells required (over 20) in a relatively small injection area combined with limited groundwater storage capacity.

The following assumptions were used for **IPR1** series options (Injection in Montecito Basin):

- Assumes injection well rate of 100 GPM (~150 AFY) based on 50% of typical production rate of 200 GPM for existing extraction wells in the Montecito Basin.
- IPR MSD1 & NPR MSD3 combination assume the AWT is operated for the portion of the year that groundwater injection occurs, which is roughly 6 months of lower irrigation demands (October-March).
- The AWT location for IPR SB1a and SB1B is not specified and may require additional cost for land purchase.
- IPR MSD/SB1 assumes a total yield of 1,100 AFY to match SB1a and SB1b. The supply is assumed to be maximized from MSD (540 AFY) and the balance of 560 AFY from the City.

The following assumptions were used for **IPR2** series options (Injection in Toro Canyon Sub-basin):

- Assumes injection well rate of 100 GPM (~150 AFY) based on 50% of typical production rate of 200 GPM for existing extraction wells in the Toro Canyon Sub-basin.
- The Toro Canyon Sub-basin is a relatively small basin with private wells scattered throughout the area so identifying injection locations that would provide sufficient travel time may be challenging.

The following assumptions were used for **IPR3** series options (Injection in Carpinteria Basin):

- IPR MSD3a assumes delivery of AWT water from MSD to the vicinity of the Carpinteria IPR Project injection wells for injection with new injection wells.
- IPR MSD3b assumes conveyance of MSD secondary treated wastewater to the Carpinteria AWT at the CSD WWTP to expand the 1.0 MGD Carpinteria IPR Project treatment, conveyance, and injection facilities to 1.5 MGD. MWD is assumed to be a one-third participant in the project based on 0.5 MGD of 1.5 MGD.
- Assumes injection well rate of 350 GPM (~540 AFY) based on 50% of typical production rate of 700 GPM in the Carpinteria Basin.
- Groundwater modeling must be conducted to evaluate the ability of the basin to accept 0.5 MGD from MWD in addition to the 1.0 MGD in the proposed Carpinteria IPR Project.
- For MWD to realize the project yield, a water exchange is needed between MWD and CVWD, such as delivery of treated surface water from Lake Cachuma, or other source via the South Coast Conduit and Cater WTP. Determining the cost of the exchange involves multiple factors, such as losses (evap, system and leave behind), CVWD's supply availability, delivery point, etc., that is beyond the scope of this effort. The assumption should be refined with CVWD.

The following assumptions were used for **IPR4** option (Carpinteria IPR Project partnership):

- Considers a potential partnership between MWD and CVWD on CVWD's proposed IPR project in the Carpinteria Basin to inject 1.0 MGD (1,100 AFY) from CSD.
- A yield of 540 AFY is assumed to equal the MSD IPR options.
- The Project partnership conditions must be refined with CVWD. In particular, the mechanism and cost of the water exchange needed for MWD to receive supply from the project must be defined (similar to IPR3 options).
- Recycled water alternatives from MSD, SSD, or City can be considered along with IPR4 since IPR4 uses CSD wastewater and does not require MWD to provide a wastewater or recycled water supply.

5.3.2.1 IPR Alternatives Evaluation

Capital, operating, and unit costs were developed for each alternative applying the criteria described in Section 5.2.2. The capital costs are shown in Figure 26 and unit costs are shown in Figure 27. Detailed cost estimates are included in Appendix B.

Figure 26: IPR Alternatives, Capital Costs (\$M)

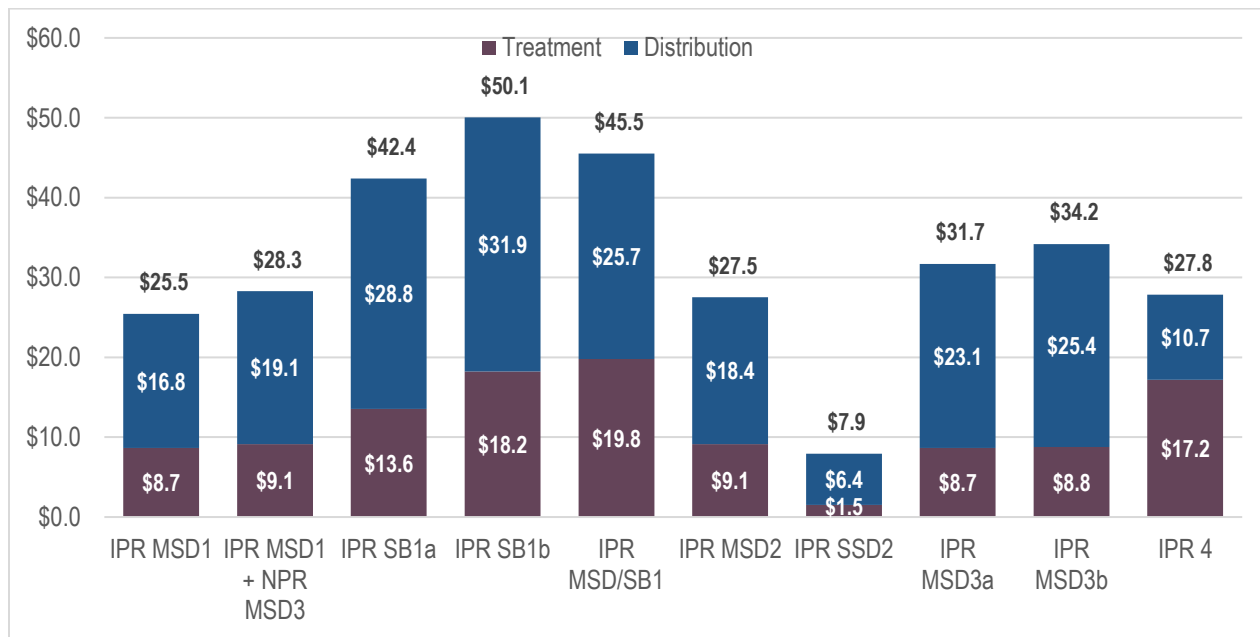

Note: Recycled water purchase price for City (SB) options are not included in this figure.

Figure 27: IPR Alternatives, Unit Costs (\$/AF)

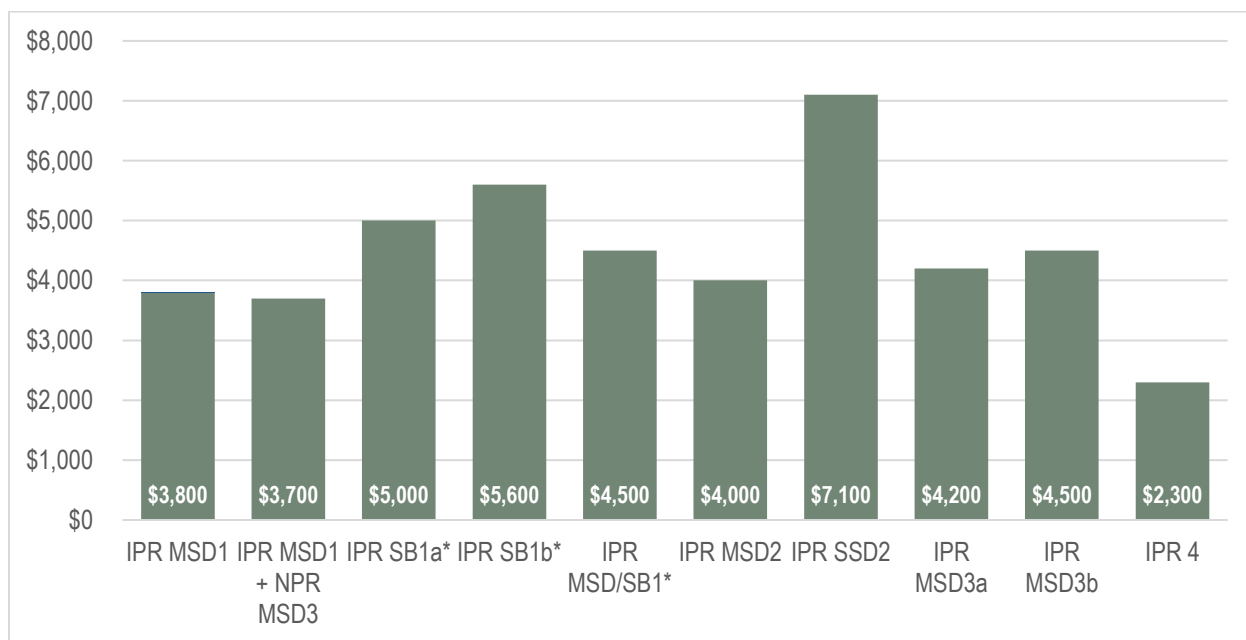

Note: Unit costs include annual O&M and annualized capital cost assuming SRF financing of 2.0% interest rate over 30 years.

*Includes City (or SB) recycled water purchase price of \$2,600/AF.

The following conclusions can be made based on comparing the cost estimates:

- MSD options in the Montecito Basin are lower cost than the City options. Therefore, MSD options are preferred over City options unless the City's purchase price reduced by roughly 40 percent considering the high year-round use.
- Montecito Basin and Toro Canyon Sub-basin options from MSD (MSD1, MSD2) are more cost effective than Carpinteria Basin (MSD3) options. Therefore, Montecito Basin and Toro Canyon Sub-basin options are preferred.
- MSD1 and MSD2 are similar cost but Montecito Basin Storage Unit 1 (MSD 1) likely provides a more conducive setting for an IPR project than Toro Canyon Sub-basin (MSD 2) considering Storage Unit 1's larger storage volume and existing MWD wells, groundwater rights, and limited private wells near Birnam Wood Golf Course.
- Combining IPR MSD1 with NPR MSD3 has a relatively similar unit cost but the NPR component could be the first phase of the larger IPR project.
- IPR4 has the lowest unit cost; however, the unit cost does not include any cost for water exchange. IPR 4 could be implemented in parallel with the other recycled water options since the recycled water source is from CSD rather than MSD and doesn't involve conveying MSD wastewater to CSD.

Based on these conclusions, IPR MSD1 and IPR4 are recommended for further consideration as top alternatives. IPR MSD1 + NPR MSD3 Combo should be considered if NPR MSD3 is selected as the recommended first phase project. IPR MSD2 should be considered as a second tier IPR alternative and be included in recommended hydrogeological study. As noted above, a hydrogeological study must be conducted to confirm the capacity to store water in the Montecito Basin and Toro Canyon, respectively, and ability to meet minimum travel time. Also, confirm location of private wells. The IPR alternatives with findings are summarized in Table 29.

Table 29: IPR Alternatives, Cost Summary

Project	Source	Yield (AFY)	Total Capital Cost	Unit Cost (\$/AF) ⁽¹⁾	Finding
IPR1: Montecito Basin					
IPR MSD1	MSD	540	\$25,450,000	\$3,800	Top
IPR MSD1 + NPR MSD3 Combo	MSD	550	\$28,280,000	\$3,700	Top
IPR SB1a	City	1,100	\$42,390,000	\$5,000 ⁽²⁾	Screened Out
IPR SB1b	City	1,100	\$50,060,000	\$5,600 ⁽²⁾	Screened Out
IPR MSD/SB1	MSD & City	1,100	\$45,510,000	\$4,500 ⁽²⁾	Screened Out
IPR2: Toro Canyon					
IPR MSD2	MSD	540	\$27,530,000	\$4,000	Second Tier
IPR SSD2	SSD	90	\$7,930,000	\$7,100	Screened Out
IPR3: Carpinteria Basin					
IPR MSD3a	MSD	540	\$31,710,000	\$4,200	Screened Out
IPR MSD3b	SSD	540	\$34,190,000	\$4,500	Screened Out
Project Partnership					
IPR 4: Carpinteria, IPR Project	CSD	540	\$27,830,000	\$2,300	Top

Notes:

1. Includes annual O&M and annualized capital cost assuming SRF financing of 2.0% interest rate over 30 years.
2. Includes City purchase price of \$2,600/AF.

5.3.3 Direct Potable Reuse Alternatives

Four DPR alternatives were defined (Table 30, Figure 21) for raw water augmentation (RWA) or treated drinking water augmentation (TDWA). As shown in Figure 28, RWA assumes “AWT+” water conveyed to a surface water treatment plant for treatment and distribution while TDWA assumes “AWT++” water conveyed directly to the potable distribution system. “AWT+” is advanced water treatment (AWT) (UF/RO/AOP) plus an additional disinfection step while “AWT++” = AWT+ plus ozone and BAC.

Table 30: Direct Potable Reuse Alternatives, Summary

Project	Source & Treatment Location	Level of Treatment ⁽¹⁾	Treatment Capacity	Pipe Diameter & Length	Yield (AFY)
DPR 1: RWA at Bella Vista WTP	MSD WWTP	AWT+	0.5 MGD	10" @ 31,200 ft	540
DPR 2: TDWA at Romero Reservoir	MSD WWTP	AWT++	0.5 MGD	10" @ 26,700 ft	540
DPR 3: TDWA at Distribution System	MSD WWTP	AWT++	0.5 MGD	10" @ 6,700 ft	540
DPR 4: City RWA Project Partnership	City WWTP	AWT+	6.2 MGD	12" @ 11,500 ft 16" @ 14,000 ft	540 (of 6,300) ⁽²⁾

Notes:

1. “AWT+” = AWT (UF/RO/AOP) plus an additional disinfection step; “AWT++” = AWT+ plus ozone and BAC.
2. DPR 4 yield for MWD is undetermined so a similar yield as the other DPR projects was assumed. The full project is estimated to produce 6,300 AFY.

Figure 28: Direct Potable Reuse Alternatives, System Schematics

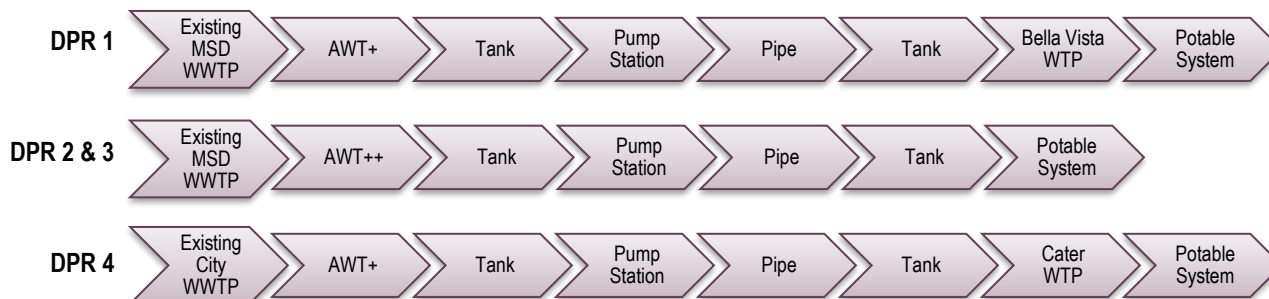

RWA regulations in California are currently under development and are expected by 2023 while there is no schedule for TDWA regulations. Therefore, RWA and TDWA treatment, storage, and monitoring assumptions (Section 3.3.4.3) were made based on anticipated regulations but must be revisited once regulations are developed. As a result, RWA alternatives should be revisited once regulations are developed.

TDWA alternatives (DPR 2 and DPR 3) are not likely to be implemented in a timely manner due to a lack of regulations and lack of a timetable to develop regulations so they are not considered further. DPR 1 could be part of a phased project implementation where NPR MSD3 (golf courses) and/or IPR MSD1 (Montecito Basin) and the NPR/IPR project is extended to DPR targets.

The 2017 City of Santa Barbara Potable Reuse Feasibility Study (Carollo) identified RWA at Cater WTP as a long-term DPR alternative. DPR 4 (City RWA Project Partnership) assumes MWD would buy into a portion of the City’s project.

DPR 4 yield of 540 AFY was set to the same as the other DPR alternatives, which is 9% of the total project yield - 6,300 AFY. The project will not likely be implemented for 10 or more years.

5.3.3.1 DPR Alternatives Evaluation

The DPR alternatives are speculative since numerous facility and operational assumptions were made in absence of regulations. Capital, operating, and unit costs were developed for each alternative applying the criteria described in Section 5.2.2. The capital costs and unit costs are summarized in Table 31. Detailed cost estimates are included in Appendix B. The lack of regulations results in substantial uncertainty in the project components that will be required in the future once regulations are developed and, therefore, the unit costs have the to change substantially.

DPR 1 and 4 (raw water augmentation) should have regulations by 2023 while DPR 2 and 3 (treated drinking water augmentation) do not have a schedule for regulations. Therefore, DPR 1 and 4 are recommended for future consideration. DPR 1 should be considered as a future phase that incorporates initial NPR and/or IPR alternatives. Also, DPR 1 and DPR 4 could be implemented in parallel since they are two different sources of water.

Table 31: DPR Alternatives, Cost Summary

Project	Source	Yield (AFY)	Capital Cost (\$M)	Unit Cost ⁽¹⁾ (\$/AF)	Finding
DPR 1: RWA at Bella Vista WTP	MSD	540	\$24.8	\$4,300	Second Tier
DPR 2: TDWA at Romero Reservoir	MSD	540	\$27.1	\$4,700	Screened Out
DPR 3: TDWA at Distribution System	MSD	540	\$20.8	\$4,000	Screened Out
DPR 4: City RWA at Cater WTP Partnership	City WW	540 ⁽²⁾	\$14.4	\$2,900 ⁽²⁾	Second Tier

Notes:

1. Unit costs include annual O&M and annualized capital cost assuming SRF financing of 2.0% interest rate over 30 years.
2. DPR 4 yield was set equal to the other DPR alternatives and assumes MWD would fund 9% of the overall project (based on 540 AFY for MWD of 6,300 AFY project). Does not include any cost for water purchase or exchange

5.3.4 Non-Recycled Water Alternative

In the event a recycled water project is not pursued, projected recycled water supplies would be met with an alternative source of water. Existing MWD sources are already being used to meet current demands, especially during extended drought periods, therefore an additional water supply must be identified to meet projected recycled water supplies. The District's goal of achieving 85% local, reliable supplies by 2025 means this alternative supply must be local and reliable given MWD is already heavily reliant on non-local, unreliable sources. SWP supplemental purchases are highly unreliable with no guaranteed availability from year to year and local groundwater supply is not sufficient to replace the recycled water supplies. For these reasons, the only additional available local supply to offset recycled water supplies is desalinated water.

Desalinated water could be available to MWD through the implementation of an MWD owned and operated desalination facility or through an arrangement with a regional agency providing desalinated water. This source would be local, reliable and rainfall independent. However, this supply is expensive due to high capital and operating costs. Additionally, an MWD owned and operated facility could require years for regulatory approvals and would not provide the economies of scale of a regional facility. For a regional desalinated water supply agreement, institutional agreements between agencies will add time and expense to the process of acquiring this supply. The estimated unit cost of additional supply from desalinated water would range from approximately \$2,500 per AF to \$4,000 per AF depending on regulatory approvals, institutional agreement terms, and economies of scale.

5.3.5 Summary of Alternatives Evaluation

The purpose of this alternatives analysis is an initial comparative evaluation between the alternatives primarily based on cost to identify the top alternatives to carry forward for more detailed definition and evaluation. The following recommendations were made based on the alternatives definition and analysis:

- NPR MSD1 (Cemetery) and MSD3 (Golf Courses) are the top NPR alternatives.
- IPR MSD1 (Montecito Basin) and IPR4 (Carpinteria IPR Project Partnership) are the top IPR alternatives.
- NPR MSD 3a (Manning Park Extension), MSD3c (Agricultural Extension), SSD2 (Max SSD Irrigation) are a second tier of NPR projects that could be pursued in addition to the top NPR alternatives.
- IPR MSD1 is preferred over IPR MSD2 (Toro Canyon Sub-basin) since Montecito Basin has better IPR operational characteristics (MWD groundwater rights, storage capacity, existing MWD wells, limited private wells) than Toro Canyon Sub-basin. Although, the feasibility of groundwater augmentation in the Montecito Basin and Toro Canyon Sub-basin must be investigated.
- Alternatives with City supplies have higher unit costs than those with MSD supplies. A 40 to 50 percent lower price than the current price of \$2,600/AF would be more competitive with MSD supplies.
- IPR 4 (Carpinteria IPR Project Partnership) has a low unit cost but must be discussed further with CVWD. This alternative could be pursued in parallel with other preferred alternatives since it does not impact use of MSD, SSD, or City wastewater.
- The MWD 2015 UWMP recycled water goal of 1,000 AFY by 2025 exceeds available recycled water supplies within MWD service area. Projects within and outside of the service area are needed to meet this goal.
- Projects could be implemented in phases, such as NPR and then IPR and/or DPR once regulations are developed, without stranding assets
- DPR projects are not recommended at this time due to a lack of regulations and associated unknowns with the necessary capital and O&M costs but should be considered as a future phase.

The findings and recommendations include the following substantial qualifications:

- MSD flows are assumed to increase from current flows of 0.5 MGD to 0.6 MGD in the next few years and the minimum ocean discharge of 0.1 MGD is assumed to decrease to 100% RO concentrate in some scenarios.
- NPR alternatives assume customers will take recycled water at the proposed quality and price to meet their estimated recycled water demand. Increased RO to improve water quality will increase project costs.
- IPR alternatives in the Montecito Basin and Toro Canyon Sub-basin require a groundwater investigation to confirm project feasibility.
- Regional partnership with CVWD requires further evaluation by CVWD of the cost and risk of providing water exchange deliveries.

5.4 Top Alternatives Definition and Evaluation

Based on the alternatives evaluation, four alternatives were selected for more detailed evaluation:

- **Alt A – Small NPR:** NPR MSD1 – Santa Barbara Cemetery from MSD WWTP
- **Alt B – Large NPR:** NPR MSD3 – Golf Courses from MSD WWTP
- **Alt C – Montecito Basin IPR:** IPR MSD1 – Montecito Basin Groundwater Augmentation from MSD WWTP
- **Alt D – Carpinteria IPR Partnership:** IPR 4 – Carpinteria IPR Project Partnership

Each project is defined and evaluated below.

5.4.1 Top Alternatives Definition

To better define the Alternatives A, B, and C, process facilities were preliminary sized, and a preliminary layout was developed to identify area needed for the treatment plant and to develop quantities for the cost estimate (e.g., concrete, excavation, etc.). For Alternative D, treatment layouts and treatment vendor quotes from the Carpinteria Recycled Water Facilities Plan (Woodard & Curran 2016) were used. The refined facilities for each alternative are summarized in Table 32.

Table 32: Top Alternatives, Facilities

Component	Units	Alt A	Alt B	Alt C	Alt D
Secondary Equalization	MG	0.02	0.10	0.10	0.2
UF Membranes	MGD	0.20	0.60	0.60	1.2
RO Membranes	MGD	0.10	0.30	0.50	1.0
UV Reactor	MGD	0.20	0.55	0.50	1.0
Recycled Water Storage	MG	0.07	0.20	0.05	0.1
Recycled Water Pump Station	HP	30	110	50	90
Distribution Pipeline (Diameter & Length)		8-in dia. @ 700 LF	12-in dia. @ 21,000 LF	8-in dia. @ 26,500 LF	12-in dia. @ 8,400 LF

Note: Recycled water pump station includes 1 duty pump and 1 standby pump.

More detailed cost estimates were developed based on greater facilities definitions. Unit costs were developed based on estimates from recent recycled water projects in California, vendor quotes, and RSMeans construction cost data. Pipeline unit costs were developed using Woodard & Curran’s pipeline cost estimating tool with inputs specific to the study area. Treatment equipment costs were developed based on the following sources:

- Project specific equipment vendor quotes: For the major treatment processes, UF, RO, and UV, Woodard & Curran coordinated with vendors (Evoqua, AWC, Suez, and IDE Tech for UF and RO; TrojanUV for UV) to get project-specific budget quotes for the capacities included in the conceptual projects.
- Previous project experience: Woodard & Curran has recent project experience planning and designing several aspects of the treatment systems included in the conceptual projects, including UF, RO, UV disinfection, concrete construction, pumps, mixers, blowers, and other items.

The top alternatives cost estimates are summarized in Table 33 and presented in Appendix C. As shown in the table, the cost of Alt A roughly doubled from the alternative definition due to multiple factors. The primary factors are that:

- the treatment facilities lose economies of scale at this size – it’s 1/3 the size of Alt B but is 60% of the capital cost from vendor quotes;
- the treatment plant footprint (and associated concrete and building costs) are relatively high compared to the treatment capacity; and
- much of the annual O&M is for operator labor, which may be covered by existing MSD/MWD staff but has not been determined.

Table 33: Top Alternatives, Cost Estimates

Component	Alt A: Small NPR (NPR MSD1)	Alt B: Large NPR (NPR MSD3)	Alt C: Montecito Basin IPR (IPR MSD1)	Alt D: Carpinteria IPR Partnership (IPR 4)
Construction Cost	\$4.2	\$12.6	\$24.0	\$21.4
Implementation Costs	\$1.0	\$3.2	\$7.2	\$6.4
Total Estimated Capital Cost	\$5.2	\$15.8	\$31.2	\$27.8
Annualized Capital Costs				
Annualized Capital Costs	\$0.23	\$0.70	\$1.39	\$1.24
Total Annual O&M	\$0.19	\$0.50	\$0.73	\$1.16
Total Annualized Cost	\$0.43	\$1.20	\$2.12	\$2.40
Project Unit Costs				
Recycled Water Yield (AFY)	80	367	540	1,100 ²
Project Unit Cost (\$/AF)	\$5,300	\$3,300	\$3,900	\$2,200

Notes:

1. Refer to Appendix C for detailed cost estimates.
2. The total project yield is 1,100 AFY. The MWD partnership with CVWD is subject to negotiation regarding the yield and cost to exchange the project water with water from Cater WTP.

5.4.2 Top Alternatives Evaluation

In addition to cost, less quantifiable but important characteristics of each alternative should be considered. All alternatives provided general recycled water benefits, including:

- Local water supply that is drought resistant
- Reduces MWD’s reliance on surface water supplies, which are subject to increasing variability, lower yield, and increased costs.
- Allows for an equivalent usage above the urban water use limit established in MWD’s 2015 UWMP in accordance with SBX7-7
- Progress toward MWD’s recycled water goals

Qualitative considerations that may differ between each alternative include:

- Customers: Number, Level of commitment, Water source to be offset
- Institutional needs: How reliant is MWD on other public agencies or institutions to implement the project
- Regulatory risk: What is the risk that project may not be approved by regulatory agencies
- Public acceptance: What is the risk that the public may not approve of the project
- Implementation flexibility: Can the project be implemented incrementally to spread out capital expenditures or help justify the future phases
- Other benefits: Are there other ancillary benefits not already captured.

Considerations for **Alternative A** (Small NPR) Include:

- Customers: Includes only one customer (Santa Barbara Cemetery) that has expressed interest in use of recycled water.
- Institutional: An agreement between MWD and MSD is required for implementation and operation of the new water reclamation facility (WRF). A customer agreement will be needed as well.
- Regulatory: This is a straight forward recycled water irrigation project so no regulatory issues are anticipated.

- Public: Recycled water irrigation is a well-accepted use in California so no substantial public opposition is anticipated.
- Implementation: This is a small, simple project. Consideration should be made whether to oversize facilities where appropriate to accommodate future NPR or IPR expansion.
- Other: Can be implemented the quickest of the alternatives due to its smaller size

Considerations for **Alternative B** (Large NPR) Include:

- Customers: Includes 8 customers, some who have sensitive plants so recycled water acceptance is not guaranteed at this point. However, the three largest customers - Santa Barbara Cemetery and the two golf courses – could justify the project on their own and should be the focus to convert to recycled water. Both golf courses use a mixture of groundwater and potable water from MWD. In addition, Birnam Wood receives non-potable groundwater from MWD. These deliveries are assumed to continue and to help meet the peak season water demands.
- Institutional: An agreement between MWD and MSD is required for implementation and operation of the new water reclamation facility (WRF). Customer agreements will be needed as well.
- Regulatory: This is a straight forward recycled water irrigation project so no regulatory issues are anticipated.
- Public: Recycled water irrigation is a well-accepted use in California so no substantial public opposition is anticipated.
- Implementation: This project could be implemented in phases, such as to the cemetery and/or other proximate customers first. However, the golf courses are the largest demands and their use results in lower unit costs. The facilities could be converted for IPR or DPR uses in the future (along with IPR or DPR upgrades).
- Other: Allows golf courses and cemetery to irrigate even under strict drought restrictions.

Considerations for **Alternative C** (Montecito IPR) Include:

- Customers: The Montecito Groundwater Basin, Unit 1 is the “customer” and, as noted previously, hydrogeological study must be conducted to confirm capacity to store water in the basin and ability to meet minimum travel time. Also, need to confirm location of private wells.
- Institutional: An agreement between MWD and MSD is required for implementation and operation of the new water reclamation facility (WRF).
- Regulatory: DDW and RWQCB have permitted injection of AWT water. The approval process is well defined but entails risks due to strict regulatory requirements.
- Public: Recharge of AWT recycled water has encountered public opposition in the past but has increased in recent years as drought implications were felt and existing projects continue to operate safely. Injection appears to have local support (based on public Board meetings) and several projects are moving forward across California.
- Implementation: This project can only happen in one phase unless it builds on top of Alt B infrastructure. It could be a future recycled water project phase of Alt A or B.
- Other: The project could integrate with MWD’s efforts under the Sustainable Groundwater Management Act, which are just starting. The high quality AWT water should improve groundwater quality in the area influenced by the injection wells.

Considerations for **Alternative D** (Carpinteria IPR Project Partnership) include:

- Customers: The Carpinteria Groundwater Basin is the “customer” and is well defined and understood. Preliminary groundwater modeling and evaluations have shown the basin’s capacity to store water in the basin and meet minimum travel time requirements

- **Institutional:** An agreement between MWD and CVWD is required, including exchange of water to receive the yield from the project.
- **Regulatory:** DDW and RWQCB have permitted injection of AWT recycled water. The approval process is well defined but entails risks due to strict regulatory requirements.
- **Public:** Recharge of AWT recycled water has encountered public opposition in the past but has increased in recent years as drought implications were felt and existing projects continue to operate safely. Injection appears to have local support (based on public Board meetings) and several projects are moving forward across California. Also, there may be opposition from Carpinteria representatives if the project is seen as only benefiting Montecito.
- **Implementation:** This project can only happen in one phase. It has for expansion if additional flows are available.
- **Other:** The project helps MWD meet the recycled water goal of 1,000 AFY by 2025 since existing MSD flows are not high enough to produce this much recycled water. The project could help integrate with emergency preparedness through interagency supply planning.

A rough representation of the qualitative assessment is presented in Table 34.

Table 34: Top Alternatives, Qualitative Assessment Summary

Alt	Yield (AFY)	Unit Cost (\$/AF)	Advantages	Disadvantages
A	80	\$5,300	<ul style="list-style-type: none"> • No anticipated regulatory issues • Customer is interested in reuse • Limited institutional issues anticipated 	<ul style="list-style-type: none"> • Highest unit cost • Customer must agree to receive recycled water with acceptable quality at an acceptable price
B	367	\$3,300	<ul style="list-style-type: none"> • No anticipated regulatory issues • Customers are interested in reuse • Limited institutional issues anticipated 	<ul style="list-style-type: none"> • Multiple customers must agree to receive recycled water with acceptable quality at an acceptable price
C	540	\$3,900	<ul style="list-style-type: none"> • Maximizes reuse • Integrates with SGMA efforts • Improves groundwater quality • Limited institutional issues anticipated 	<ul style="list-style-type: none"> • Risk of infeasible project pending hydrogeological study results • Burdensome project approval process
D	540	\$2,200	<ul style="list-style-type: none"> • Lowest unit cost • Feasible project with high reuse • Can be implemented in parallel with projects within MWD service area • Integration with emergency preparedness 	<ul style="list-style-type: none"> • MWD and CVWD must still negotiate key terms, such as cost and yield • Dependence on neighboring agency to complete the project • Potential public opposition

Based on cost and qualitative assessments, the following conclusions were made:

- Alternatives A, B, and C would all use recycled water from MSD WWTP and are therefore mutually exclusive. **Alternative B** is recommended over Alternative A and Alternative C due to the lower unit cost and better qualitative assessment.
- **Alternative A** could be implemented as a first phase of Alternative B but is not recommended on its own due to the high unit cost.
- **Alternative C** could ultimately result in more yield than Alternative B but cannot be recommended until a hydrogeological evaluation determines the ability to operate the IPR project with the estimated yield and meeting regulatory requirements.

- **Alternative D** is recommended for further consideration due to having the lowest unit cost. However, the alternative does have potential institutional and public hurdles to overcome. Also, MWD must work with CVWD to determine the cost and terms of the water exchange involves multiple factors. The water exchange cost is not included.

Therefore, Alternative B (Large NPR) is the recommended alternative and Alternative D (Carpinteria IPR Partnership) is recommended for implementation in parallel. In the future, project expansions or second tier projects defined at the beginning of Section 5.5 could be implemented as a future phase after Alternative B. The recommend project includes the following substantial qualifications that will be addressed in the Implementation Plan in Chapter 8:

- MSD flows are assumed to increase from current flows of 0.5 MGD to 0.6 MGD in the next few years and the minimum ocean discharge of 0.1 MGD is assumed to decrease to 100% RO concentrate in some scenarios.
- NPR alternatives assume customers will take recycled water at the proposed quality and price to meet their estimated recycled water demand. Increased RO to improve water quality will increase project costs.
- Regional partnership with CVWD requires further evaluation by CVWD of the cost and risk of providing water exchange deliveries.

5.4.3 Future Projects

There are several variations of the top alternatives and second tier alternatives that can also be considered as a future phase. These include:

- **NPR MSD2 – Biltmore Extension** – consider if NPR system is not extended to the golf courses (Alt B) and customers express interest in recycled water use.
- **NPR MSD3a – Manning Park Extension** – consider if sufficient supply is available and customers express interest in recycled water use.
- **NPR MSD3c – Private Agricultural Extension** – consider if sufficient supply is available and customer expresses interest in recycled water use. Potential conversion of the agricultural use to large rural residential parcels was noted.
- **NPR SSD2 – Max Irrigation** – consider if potential customers express interest in recycled water use. One of the main customers is a private residence.
- **City Recycled Water** – the top alternatives could be supplemented with recycled water from the City of Santa Barbara if the demand materializes and the amount of use can justify the cost to connect to the City’s system.
- **DPR 1 – Raw Water Augmentation at Bella Vista WTP** – re-consider this project once RWA regulations are developed in 2023 and consider that Alt B (golf courses) infrastructure could be used for conveyance and extended to Bella Vista WTP.
- **DPR 4 – City of Santa Barbara Raw Water Augmentation (Cater WTP)** – re-consider this project once RWA regulations are developed in 2023 and if the City of Santa Barbara chooses to pursue the project. The pipeline that is proposed to convey desalinated water to Cater WTP may be able to be used for RWA conveyance in the future.

5.4.4 Sensitivity Analysis

Defining and evaluating recycled water projects at this stage of planning requires making multiple notable assumptions so a sensitivity analysis to some key assumptions was conducted to understand impact of changing conditions on the recommended project. The analysis considered Alternative B and looked at:

- **MSD WWTP Flows:** What if MSD WWTP effluent flows remain low and minimum ocean outfall flows are required such that available flow is 0.4 MGD rather than 0.6 MGD? This scenario assumes the system is designed for 0.4 MGD.

- Lower Demand: What if the system is designed for 100% of the demand estimate (0.6 MGD capacity yielding 367 AFY) but only 75% of the demand materializes (0.6 MGD capacity yielding 275 AFY)?
- 100% RO: What if all recycled water is treated with RO rather than 50% to meet customer water quality requirements?
- No RO: What if no recycled water is treated with RO rather than 50%?
- SRF Financing: What if the SRF interest rate increases from 2.0% to 3.0% over 30 years?
- Grant Funding: What if MWD receives grant funding for 25% of capital cost. (Grants are rarely given for O&M costs).

As shown in Table 35, lower demand and adding RO capacity would have the biggest potential to increase unit costs while avoiding RO has the biggest potential to reduce unit costs. RO assumptions will be confirmed through additional meetings with the potential customers and potentially from results from MSD's Recycled Water Pilot Project. Having lower demands than anticipated can be mitigated by thorough customer meetings to result in agreement on recycled water quantity, quality, and price and documentation in a customer agreement. The other item that has high potential to lower unit costs is grant funding and MSD and MWD intend to be aggressive in pursuit of grant funding. (Opportunities are discussed further in Section 7.2). Finally, lower MSD flows and higher SRF loan interest rates have the potential to increase unit costs slightly. The MSD flows finding emphasizes the importance of determining available flows prior to constructing the project so that the system can avoid being oversized and less cost effective. MWD cannot do much to control interest rates besides moving forward with the project promptly and planning for the impact if rates increase by the time of construction.

Table 35: Alternative B (Large NPR), Sensitivity Analysis

Category	Yield (AFY)	Capital Cost (\$M)	Unit Cost (\$/AF)	% Unit Cost Increase (+) or Decrease (-)
Baseline	367	\$15.8	\$3,300	
1. MSD WWTP Flows	312	\$14.3	\$3,500	+6%
2. Lower Demand	275	\$15.9	\$4,200	+27%
3. 100% RO	346	\$19.1	\$4,200	+27%
4. No RO	373	\$12.7	\$2,600	-21%
5. SRF Financing	373	\$15.9	\$3,500	+6%
6. Grant Funding	373	\$11.9	\$2,800	-15%

5.4.5 Other Considerations

5.4.5.1 Climate Change

A topic of growing concern for water planners and managers is climate change and the potential impacts it could have on California's future water supplies. Climate change models have predicted that potential effects from climatic changes include: increased temperature, reduction in Sierra Nevada snowpack depth, early snow melt and a rise in sea level.

All of the recycled water alternatives improve MWD's climate change resilience by increasing reliance on local supplies with a lower embedded energy than SWP supplies and a supply that is not impacted by changes to temperature, precipitation, and snowpack.

5.4.5.2 State Planning Priorities

California Government Code Section 65041.1 define the State’s “planning priorities, which are intended to promote equity, strengthen the economy, protect the environment, and promote public health and safety in the state, including in urban, suburban, and rural communities” and are:

- To promote infill development and equity
- To protect environmental and agricultural resources
- To encourage efficient development patterns

All of the alternatives protect the environment by reducing the use of imported water and reducing ocean discharges. The alternatives with higher yield provide a larger environmental protection benefit. In addition, the alternatives help to protect agricultural resources by providing a long-term, locally controlled, and drought resistant water supply.

5.4.5.3 Sustainable Water Resources Management

The alternatives developed are in alignment with SWRCB Resolution No. 2008-0030 which requires Sustainable Water Resources Management and acknowledges that sustainable water resources management is vital to California's future. Recycled water is among the most sustainable water resources as it reuses wastewater as opposed to allowing the wastewater to be discharged to the ocean and provides a drought resistant source. The resolution further directs SWRCB staff to assign a higher grant priority to climate related projects that are supported by local policies and ordinance.

6. RECOMMENDED PROJECT

This chapter describes the Recommended Recycled Water Project (Recommended Project) and includes target customers, project facilities descriptions, cost estimates, project benefits and an implementation plan (including construction financing plan). Alternative B was chosen as the Recommended Project.

6.1 Facilities

The Recommended Project involves the construction of a new 0.6 MGD water reclamation facility (WRF) at the MSD WWTP and a recycled water distribution system. The WRF includes secondary equalization, UF membranes, RO membranes (for a portion of flow), and UV disinfection. The planning-level treatment plant layout for the Recommended Project is illustrated in Figure 29. The recycled water distribution system includes a recycled water storage tank, recycled water pump station, and approximately 21,000 LF of 12-inch diameter pipeline to various customers. The distribution system and customers for the Recommended Project are illustrated in Figure 30.

The Recommended Project would deliver roughly 370 AFY of recycled water for irrigation. A list of recycled water customers for the Recommended Project and their respective estimated average annual demands is presented in Table 36.

Table 36: Recommended Project, Recycled Water Customers

Customer	Recycled Water Demand Estimate	
	Avg Annual (AFY) ⁽¹⁾	Max Day (MGD) ⁽¹⁾
Valley Club Montecito	150	0.27
Birnam Wood Golf Club	100	0.18
Santa Barbara Cemetery	80	0.14
Four Seasons Biltmore	15	0.03
Miramar Hotel	11	0.02
Private Residence	9	0.02
Ty Warner Hotels	6	0.01
Music Academy of West	2	0.004
Total	373	0.67
Maximum Yield with Available MSD Supply ⁽¹⁾	367	0.54

Note:

- Actual demand served from MSD is limited by the available recycled water – estimated as 0.54 MGD – so only a portion of irrigation demand will be met with recycled water. Refer to Figure 17, which demonstrates this concept. For comparison purposes, City alternatives are assumed to be limited to this volume too.

MWD has the option to expand the treatment facilities to conduct advanced water treatment (UF/RO/AOP) on all flow in the future if groundwater recharge with recycled water is deemed feasible and cost effective. Also, MWD would be able to import recycled water from the City of Santa Barbara to supplement MSD recycled water in the future if demands and cost justify the addition.

\\woodardcurran.net\shared\Projects\BMC\LA\0699 Montecito Water District\0011083.00 MWD RW Facilities Plan\B. Project Work\5. Report\CAD\Layout.dwg



888 South Figueroa Street, Suite 1700
 Los Angeles, California 90017
 213.223.9460 | www.woodardcurran.com

WOODARD & CURRAN
 COMMITMENT & INTEGRITY DRIVE RESULTS

Figure 29
Recommended Facility
Layout

DESIGNED BY: MMC
 CHECKED BY: Rob Morrow
 DRAWN BY: MMC
 LAYOUT.dwg

Montecito Water District
 583 San Ysidro Rd, Montecito, CA 93108

MWD Recycled Water Facilities Plan

JOB NO: 0011083.00
 DATE: November 2018
 SCALE: 1:600

Figure Exported: 10/31/2018 By: mdemania Using: \\woodardcurran.net\shared\Projects\RM\CL\0695\Montecito\Water_District\0011083_00_MWD_RW_Facilities_Plan\G_GIS\MXDs\Recommended Project.mxd

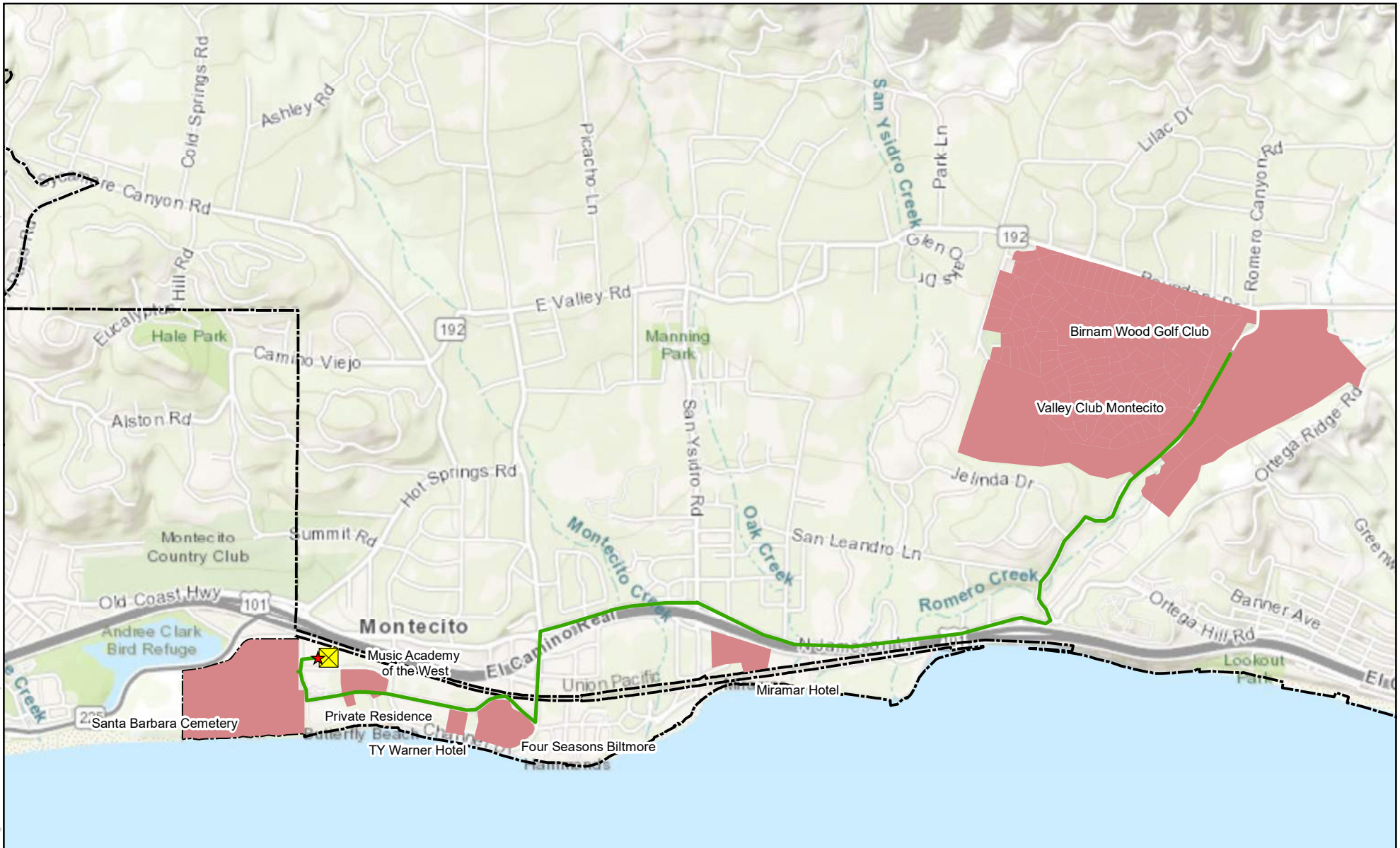

Note: The pipeline alignment shown is preliminary and will be evaluated during future design phases.

MWD Recycled Water Facilities Plan

Figure 30 Recommended Project

Legend

- ★ Proposed AWTF
- ✘ Montecito WWTP
- 🟩 NPR MSD3
- 🟥 Landscape Irrigation Customers
- ⬜ Montecito Water District

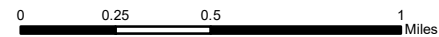

Project #: 0011083
Map Created: November 2018

Third Party GIS Disclaimer: This map is for reference and graphical purposes only and should not be relied upon by third parties for any legal decisions. Any reliance upon the map or data contained herein shall be at the users' sole risk. **Data Sources:**

ADMIN DRAFT

A summary of key planning-level design criteria for the Recommended Project's facilities is presented in Table 37.

Table 37: Recommended Project, Design Criteria

Component	Value	Units	Notes
Secondary Equalization	0.1	MG	
UF Feed Pumps	7.5	HP	1 duty, 1 standby
UF Membranes	0.6	MGD	
UF Backwash Pumps	4	HP	
RO Feed Pumps	50	HP	
RO Membranes	0.3	MGD	
UV Reactor	0.6	MGD	100 mJ/cm ² , 55% UVT
Recycled Water Storage	0.2	MG	
Recycled Water Pump Station	110	HP	1 duty, 1 standby
Distribution Pipeline	21,000	LF	12-inch PVC

6.2 Recommended Project Cost Estimate

Table 38 summarizes the estimated cost for the Recommended Project. See Appendix D for detailed cost information.

Table 38: Recommended Project Costs

Div	Component	Value
2	Sitework	\$6,458,000
3	Concrete	\$296,000
4	Masonry	\$178,000
5	Metals	\$62,000
11	Equipment	\$1,992,000
13	Special Construction	\$329,000
15	Mechanical	\$399,000
16	Electrical	\$399,000
17	Instrumentation and Controls	\$399,000
Subtotal Raw Construction Cost		\$10,502,000
Construction Contingency		\$2,100,000
Base Construction Cost		\$12,602,000
Implementation Costs		\$3,154,000
Total Estimated Capital Cost		\$15,756,000
Annual Costs		
Annual Cost of Consumables		\$109,000
Annual Cost of Power		\$141,000
Annual Labor Costs		\$250,000
Total Annual O&M		\$500,000
Annual Costs		
Annualized Capital Costs		\$704,000
Annual O&M		\$500,000
Total Annualized Cost		\$1,204,000
Project Unit Costs		
Recycled Water Yield (AFY)		367
Project Unit Cost (\$/AF)		\$3,300

7. IMPLEMENTATION PLAN

This chapter introduces the steps necessary to implement the Recommended Project, including institutional needs, funding opportunities, financing plan, environmental documentation, design, and construction activities.

7.1 Institutional Needs

7.1.1 Interagency/Customer Agreements

The primary agreement needed for the project is between MSD and MWD regarding design, construction, operation, and ownership of the new water reclamation facility at the MSD WWTP. MWD would also pursue individual customer agreements where appropriate.

7.1.2 Permitting

Several permits specific to recycled water are necessary for the implementation of the Recommended Project. MWD would need to enroll under the State Water Resources Control Board General Order WQ 2016-0068-DDW for permit coverage of the distribution and use of recycled water by filing a Notice of Intent (NOI) with the Central Coast Regional Board and a Title 22 Engineering Report with the SWRCB Division of Drinking Water Field Operations Branch office.

Standard construction permits would also be required, including California Coastal Commission coastal development permit, RWQCB general construction permit / stormwater pollution prevention plan, County encroachment permit, and County air pollution control permits. Pipeline crossing of the railroad will require a permit from Union Pacific Railroad and crossing Highway 101 will require a permit from CalTrans.

7.1.3 Right of Way Acquisition

No right of way acquisition was identified.

7.2 Funding Opportunities

A variety of potential funding opportunities are possible for this project, including the following:

- Integrated Regional Water Management (IRWM) Program Funding
- US Bureau of Reclamation (USBR) WaterSMART: Title XVI Water Reclamation and Reuse Program
- SWRCB CWSRF / Water Recycling Funding Program (WRFP)
- California Infrastructure and Economic Development Bank (I-Bank) Infrastructure State Revolving Fund (ISRF) Program

Each of these funding opportunities is described in further detail in the following sections.

7.2.1 Integrated Regional Water Management (IRWM) Program Funding

The IRWM Program, administered by the DWR, provides planning and implementation grants to prepare and update IRWM Plans and to implement integrated, regional water resources related projects included in IRWM Plans. IRWM program funding is awarded through a competitive grants program, in which approved IRWM Regions submit application packages for funding multiple projects within their regions. For a project to be eligible for IRWM funding, it must be included in an IRWM Region's IRWM Plan and preferably be ready to be implemented. This project falls within the Santa Barbara County IRWM region, and therefore must be included within the Santa Barbara County IRWM Plan to be eligible for IRWM funding. IRWM funding requires a minimum 50% match for the entire grant proposal, which typically includes multiple projects from different sponsors.

Funding is currently available through Proposition 1 (Prop 1), the Water Quality, Supply, and Infrastructure Improvement Act of 2014 which made \$510 million available through the IRWM Program Statewide. Of this, \$43 million was designated for the Central Coast Funding Area and only \$2 million remains for the South Coast area of Santa Barbara County for the final two rounds. The Draft Proposal Solicitation Package was released on October 5, 2018. Based on information from DWR, the current schedule for the next round of Prop 1 implementation grant funding is as follows:

- Release of the Final Proposal Solicitation Package in late 2018;
- Pre-application workshops in February-July 2019 period; and
- Application due approximately eight weeks after pre-application workshop.

The timing of current round of IRWM funding and the limited available funding results in low potential for the recommended project. However, it is possible the funding could be replenished through another source in the future, such as Proposition 68, the Parks, Environment, and Water Bond approved in June 2018 or Proposition 3, the California Water Bond that will appear on the California ballot in November 2018.

Additional information about the IRWM grant program can be accessed here: <https://www.water.ca.gov/Work-With-Us/Grants-And-Loans/IRWM-Grant-Programs/Proposition-1>.

7.2.2 US Bureau of Reclamation (USBR) WaterSMART: Title XVI – Grant Funding

Administered by the USBR, the WaterSMART: Title XVI Water Reclamation and Reuse Program is a grant program that focuses on identifying and investigating opportunities for water reclamation and reuse. Funding is made available for the planning, design, and construction of water recycling treatment and conveyance facilities and structured to cover 25% of the total project costs (up to \$20 million), with project proponents contributing 75% or more of total project costs. Proposal requirements include technical and budgetary components, as well as a completed Title XVI Feasibility Study, which must be submitted to USBR for review and approval. While compliance with the National Environmental Policy Act (NEPA) is not required during the proposal phase, it is required prior to the receipt and expenditure of Federal funds. In the past, in order to be eligible for the Title XVI grant program, a project had to be congressionally authorized; however, with the passing of the Water Infrastructure Improvements for the Nation or WIIN Act, a project must only have a USBR-approved Title XVI Feasibility Study to be eligible. USBR typically releases Funding Opportunity Announcements for the Title XVI program on an annual basis. For reference, applications for the most recent solicitation were due July 27, 2018. Typically, a project receives its grant funding allocation through multiple rounds of funding and application solicitations. For example, a project could apply for approximately \$4 million each year until the project is constructed and/or its full grant amount is secured.

Additional information is available from USBR's website here: <http://www.usbr.gov/lc/socal/titlhexvi.html>.

7.2.3 SWRCB CWSRF/ Water Recycling Funding Program (WRFP)

The SWRCB administers multiple types of recycled water funding depending on availability: recycled water facilities planning grants, construction implementation grants and loans, CWSRF loans, and principal forgiveness. Construction grants and loans specific to recycled water programs fall under the WRFP and follow the Policy for Implementing the CWSRF. One application is submitted to SWRCB for the CWSRF/WRFP programs and SWRCB awards the best financing package possible given availability of funds (i.e., a combination of a low-interest loan, grant funding, and principal forgiveness). With the Facilities Plan in place, MWD can focus on obtaining grants or low interest loans to cover the construction implementation costs.

7.2.3.1 Clean Water State Revolving Fund (CWSRF) Program

The SWRCB administers the CWSRF Program. The CWSRF Program offers low-interest loans to eligible applicants for construction of publicly-owned facilities including wastewater treatment, local sewers, sewer interceptors, water reclamation and distribution facilities, and stormwater treatment. Funding under the CWSRF Program is also available for expanded use projects including implementation of nonpoint source projects or programs, and development and implementation of estuary comprehensive conservation and management plans.

The process for securing funds includes submitting a CWSRF application, in addition to additional water recycling project-specific application items. CWSRF loans typically have a lower interest rate than bonds, at half of the General Obligation bond (typically 2.5% to 3%, currently 1.8%) at the time of the Funding Commitment. Loans are paid back over 20 or 30 years. Repayment begins one year after construction is complete. Historically, SWRCB has funded projects on a readiness-to-proceed basis; however, SWRCB is currently revisiting the application process and may begin applying scoring criteria (to be determined). SWRCB is currently recommending interested applicants submit a complete (or as close to complete as possible) application by the end of the calendar year for inclusion on the next fiscal year's fundable list of projects. The application consists of General, Technical, Financial and Environmental Packages. The project must comply with the California Environmental Quality Act (CEQA), as well as some federal crosscutters (e.g., Clean Air Act, Federal Endangered Species Act, National Historic Preservation Act), collectively referred to as CEQA-Plus. The draft and final CEQA-Plus documentation must be submitted as part of the project's application, as well as the Notice of Determination and adopting resolution, as applicable.

Historically, SWRCB has offered up to principal forgiveness (i.e., grants) to applicants if the project directly benefits a disadvantaged community or if the project addresses priorities of its Green Project Reserve, including water recycling. Principal forgiveness is dependent upon project details and availability, and is determined after the application is submitted, during review by SWRCB.

The SWRCB is in the process of updating its CWSRF project selection process, including selection criteria. The draft policy was released for public comment in September 2018 and is intended to be finalized in November 2018. The primary changes to the process is that applications must be submitted by December 31 to be eligible for funding the following year and the SWRCB will identify a list of fundable projects that are eligible to receive a CWSRF loan after scoring each application. The scoring criteria is based on a mix of project benefits and readiness to proceed. 2019 will be the first year this approach is fully implemented and MWD's approach to acquiring a CWSRF loan should be revisited based on feedback from the new system.

More information about the SWRCB CWSRF Program can be found here:
http://www.waterboards.ca.gov/water_issues/programs/grants_loans/srf.shtml.

7.2.3.2 Facility Construction Grants

The SWRCB administers a grant program to cover construction of recycled water facilities. Per the SWRCB's WRFP Guidelines adopted on June 16, 2015, a construction grant can cover 35% of eligible construction costs up to \$15 million, including construction allowances. Eligible costs include construction allowances which may include engineering during construction, construction management, and contingencies limited to 15% of the construction grant value. To be eligible to receive grant funds, at least a 50% local cost share match must be provided. WRFP grant funding from Proposition 1 has been exhausted. It is possible the funding could be replenished through another source in the future, such as Proposition 68, the Parks, Environment, and Water Bond approved in June 2018 or Proposition 3, the California Water Bond that will appear on the California ballot in November 2018.

A CWSRF application would be submitted, and SWRCB would award the project the best package of funding available at the time of financing agreement execution, which could be a combination of a low-interest loan, grant funding, and/or principal forgiveness.

7.2.4 Infrastructure State Revolving Fund (ISRF) Program – I-Bank

The ISRF Program provides low-interest loan financing to public agencies for a wide variety of infrastructure projects such as water supply, parks and recreation facilities, sewage collection and treatment, and water treatment and distribution projects. Funding is available in amounts up to \$25 million with loan terms up to 30 years. The interest rate is set at the time the loan is approved. Eligible applicants include cities, counties, special districts, assessment districts, joint powers authorities, and nonprofit organizations. Applicants must demonstrate project readiness and feasibility to complete construction within two years after I-Bank loan approval. Additionally, eligible projects must promote economic development and attract, create, and sustain long-term employment opportunities. There is no required match; however, there is a one-time origination fee of 1% of the ISRF financing amount or \$10,000, whichever is greater. Applications are accepted on continuous basis. The I-Bank recommends applications be submitted upon completion of design, as construction must begin within six months of the I-Bank’s loan commitment.

More information about the ISRF Program can be found here: <http://www.ibank.ca.gov/infrastructure-state-revolving-fund-isrf-program/>.

7.3 Financing Plan

Figure 31 summarizes project funding and financing assumptions. MWD intends to fund pre-construction planning tasks with available funds, construction costs with a SWRCB WRFPP grant (if available), and the balance of capital costs with a low-interest SRF loan. Two scenarios are presented – with and without grant funding. As shown in the table, MWD must generate at least \$1.2 million per year in revenue and/or avoided existing costs to ensure SRF loan payback and sufficient O&M funding. The annual payment is reduced to \$1.0 million per year with grant funding. The annual payment results in a unit cost for water at this feasibility level of \$3,300/AF with a low-interest SRF loan and is reduced to \$2,800/AF with a grant covering 25% of capital costs.

Figure 31: Construction Financing and Revenue Plan Basis

Item	Baseline Cost	Cost with Grant Funds	Notes
Total Capital Cost	\$15,756,000	\$15,756,000	
Grant Amount (25%)	N/A	\$3,939,000	25% of capital costs
Capital Cost for SRF Financing	\$15,756,000	\$11,817,000	Remaining capital costs
SRF Annual Payment	\$704,000	\$528,000	SRF financing at 2.0% over 30 years
Annual O&M	\$500,000	\$500,000	
Total Annual Cost	\$1,204,000	\$1,028,000	
Annual Yield	367 AFY	367 AFY	
Unit Cost w/ Grant Funding	\$3,300/AF	\$2,800/AF	

7.3.1 Recycled Water Pricing

California Water Code 13580.7 limits recycled water rates to the estimated reasonable cost of providing the service. Recycled water rates are commonly lower than potable water rates to promote customer acceptance. The Water Reuse Rates and Charges, Survey Results (AWWA, 2008) showed that most recycled water rates range from 50 percent to 100 percent of potable water rates, with a median rate of 80 percent. This excludes settings where the purpose of

reuse is wastewater disposal, and the costs can be shared among both wastewater customers and recycled water customers. The discount acknowledges cost to convert onsite systems, as well as a lower level of service.

Rates can be set for full cost recovery (capital and O&M) or less than full recovery. Rates often vary based on the customer. For example, some industrial customers may be willing to pay higher than potable rates to ensure reliable water supply (if water quality requirements are met). And some golf courses may value the lack of water use restrictions during drought conditions, as well as the ability to reduce fertilizer applications.

Customers that are not part of a potable water system, such as sites using groundwater, may require rates to be set at the cost of existing or future supplies, which are less than potable water rates.

7.4 Technical Studies

To support project refinement and design efforts, several technical investigations are needed either prior to or in parallel of their supporting activity. This section discusses these efforts.

7.4.1 MSD WWTP Flows and Discharges

The Recommended Project assumes MSD WWTP flows will increase from 0.5 MGD (existing flows) to 0.6 MGD (flows pre-fire and debris flow events) as hotels re-build and residents and visitors return to the area. Also, the Recommended Project assumes discharge of only RO concentrate for portions of the year while MSD estimates a need to maintain minimum flows of 0.1 MGD throughout the year.

The reduced volume and increased density of effluent to the ocean outfall may impact the performance of the outfall and dilution ratios included in MSD's NPDES permit, which may require modifications to the outfall discharge ports. Also, minimum effluent velocities may be required to prevent sedimentation in outfall pipelines with shallow slopes. Therefore, an evaluation of the existing ocean outfall is recommended to understand acceptable minimum flows for times of the year where only RO concentrate is discharged and if these changes would impact MSD's NPDES permit.

7.4.2 Top Customer Commitments

The economic viability of the Recommended rests on the sale of the estimate volume of recycled water to the identified customers. Therefore, MWD should work with these customers to obtain recycled water use commitments. The commitments should be define preliminary delivery and cost conditions, including minimum annual recycled water use, maximum recycled water peak flow, minimum delivery pressure minimum recycled water quality, and recycled water rate structure.

Discussions with these customers should also focus on refining recycled water delivery conditions to reduce project capital or O&M costs to improve project economics. For example, several customers likely have sensitive turf, plants, trees, etc. that could be impacted by recycled water. A discussion with the customer could determine whether modifying irrigation practices such as adjusting spray patterns would avoid the issue or if higher quality water can be blended on-site.

Another example is if a customer has an on-site tank that can receive water during times of the day when conveyance capacity is available instead of on-demand, the recycled water storage capacity, pump station capacity, and pipeline size could be reduced. Also, delivery pressure and associated energy costs could be reduced if the system's pressure is able to be reduced based on this customer.

7.5 Environmental Review

All public projects in California must comply with the CEQA. If a project is not exempt, CEQA provides for the preparation of an Initial Study to analyze whether the project would have a significant impact upon the environment. A Negative Declaration/Mitigated Negative Declaration could be issued if the analysis in the Initial Study determines that the project or action, as proposed or as proposed with specific mitigation measures, would not have a significant impact upon the environment. If the analysis in the Initial Study determines that the project or action has the to result in a significant impact(s) to the environment, then an Environmental Impact Report (EIR) would need to be prepared to further address such impacts. In addition to CEQA, a project is subject to National Environmental Policy Act (NEPA) if it is jointly carried out by a federal agency, requires a federal permit, entitlement, or authorization, requires federal funding, and/or occurs on federal land. The SWRCB SRF loan program (see the following Section 8.2.1 for further discussion) is partially funded by the U.S. Environmental Protection Agency and, as a result, requires additional environmental documentation beyond CEQA – but not as extensive as NEPA – that is referred to as “CEQA-Plus.”

7.6 Engineering, Design, and Construction Activities

The new facilities for the Recommended Project were presented in Section 6.1. This section discusses the effort needed to develop and implement the capital improvement projects identified for the Recommended Project, including water reclamation facilities, conveyance pump stations, pipelines, and recycled water storage. Also, an ocean outfall assessment is needed to support CEQA, regulatory, and design efforts, either prior to or in parallel of their supporting activity.

7.6.1 Ocean Outfall Assessment

Reduced volume and increased concentration of effluent to the ocean outfall will impact the performance of the outfall. The change in discharge volume and effluent density could require modifications to the outfall. Therefore, an analysis should be conducted that evaluates the impacts of the Recommended Project as well as future phases being considered. The findings from this evaluation are essential in sizing the project since MSD estimates at least 0.1 MGD of ocean discharge must be maintained.

This evaluation could also support an evaluation of potential NPDES permit impacts, such as review of the California Ocean Plan for potential constituents not currently in the existing NPDES permit, review of other California projects in similar scenarios, and meeting with the Central Coast RWQCB.

7.6.2 Pre-Design Report

Detailed facilities plans would be prepared for all the new facilities identified for the project, including facility layouts for the water reclamation facility, conveyance pump stations, pipeline alignments, and recycled water storage. The plans would also include revised capital and O&M cost estimates based on vendor quotes and proposals. During pre-design, the conceptual design developed in this report would be further developed, and assumptions would be updated, validated and documented. The draft pre-design report is anticipated to take approximately six months.

7.6.3 Final Design

Following preliminary design, design packages would be prepared for the treatment and conveyance facilities. Design for the conveyance pump stations and pipelines could proceed independently of the treatment facility design. The treatment facilities and conveyance system design is expected to be completed within six to ten months. A bid package (after permitting is completed) could be prepared in two months.

7.6.4 Bidding/Contract Award, Construction, and Startup

Bidding and contract award would commence once the bid package is complete. These tasks are assumed to take three months. The bidding and contract award period is defined as starting from when the bid package is sent for advertisement to the day that the notice to proceed to the contractor is issued. Construction of the treatment facilities, conveyance pump stations, and conveyance pipelines is anticipated to take one year. The startup period and final approvals of the treatment facilities and overall project are anticipated to take three months.

7.7 Implementation Schedule

The overall implementation plan for the Recommended Project is shown on Figure 32. Full implementation of the project is anticipated to take approximately 3 years. From a project funding and financing perspective, CEQA certification is the critical path for gaining preliminary approval for grant funding and low-interest loans from the SWRCB. From a project start-up perspective, technical studies and design make up the critical path. CEQA certification is also needed before the RWQCB can issue the tentative permit. The recommended technical studies are to refine the project definition and substantiate cost feasibility. The recommended studies are: 1) evaluating maximum MSD WWTP flows and minimum discharges; 2) acquiring customer commitments and acceptable terms; and 3) conducting a hydrogeological investigation of the Montecito Groundwater Basin to determine the technical feasibility of groundwater augmentation.

Design of the infrastructure improvements would continue after completion of the relevant preliminary studies in coordination with CEQA and permitting efforts. Applications for funding and stakeholder/public outreach efforts would occur over the lifetime of the project.

Figure 32: Implementation Schedule for Recommended Project

Task	2019				2020				2021			
	Q1	Q2	Q3	Q4	Q1	Q2	Q3	Q4	Q1	Q2	Q3	Q4
Technical Studies	█											
Facilities (WRF and Distribution)												
Preliminary Design			█									
Final Design					█							
CEQA		█										
Funding / Financing	█											
Bid/Award									█			
Construction (WRF and Distribution)									█			

7.8 Future Phases

In parallel with Recommended Project activities, MWD should conduct a hydrogeological evaluation of the Montecito Basin to determine capacity to store water, ability to meet minimum travel time, and determine locations of private wells. This effort will support a decision whether to proceed with groundwater augmentation in the future.

7.8.1 Montecito Basin Hydrogeologic Investigation

The groundwater augmentation alternatives were primarily evaluated based on cost and the Montecito Basin alternatives in Storage Unit 1 and Toro Canyon Sub-basin require hydrogeological evaluation to assess the capacity

to store water in the basin and ability to meet minimum travel time. The estimated project yield would decrease if water the basin is not able to receive injected water under all hydrologic conditions and a lower yield would increase the unit costs. Also, DDW regulations have strict minimum underground retention time requirements that must be evaluated. Therefore, a hydrogeological investigation is recommended for the Montecito Basin to determine the feasibility of groundwater augmentation. The investigation would assess:

- Available storage in production zone aquifers under average, dry, and wet-year conditions
- Maximum injection rates
- Travel times
- Change in groundwater basin yield from injection
- Locations of known groundwater contamination
- Risk of geologic hazards, such as liquefaction and slope collapse
- Impacts to freshwater aquifers, local water supplies, other wells, and existing water users.
- Impacts to sensitive vegetation and habitats
- Additional production wells that may be required
- Location of private wells

The proposed hydrogeological investigation the implications of SGMA implementation on groundwater basin management will need to be considered.

8. CONCLUSION

Given the long-term risks and decreased reliability associated with the State Water Project and local surface water supplies, the Montecito Water District is committed to pursuing local, drought proof supplies. The District is committed to achieving 85% local, reliable drought proof supplies by 2025, including District groundwater, Doulton Tunnel infiltration, locally or regionally imported/purchased water, local or regional banked water, and recycled water (2015 UWMP). The District is currently implementing or is in the process of developing long-term programs and/or projects to meet future water supply needs, including this plan to evaluate recycled water options.

This plan recommends implementation of a recycled water project for irrigation of local golf courses, a cemetery, and other landscapes that are likely to remain in place for the foreseeable future. Using recycled water to meet non-potable demands avoids using high quality potable water for irrigation. The recommended project maintains the option for MWD to pursue groundwater augmentation or direct potable reuse in the future if subsequent evaluations demonstrate their feasibility and cost effectiveness such that investments in the recommended non-potable reuse project would not be stranded assets.

This plan also recommends partnering with the Carpinteria Valley Water District on their IPR project in the Carpinteria Groundwater Basin in parallel with the recommended project within MWD's service area. The partnership will require many details to be worked through – particularly the water exchange conditions.

The findings from this study now allow MWD to decide whether to move forward with recycled water in the near-term, long-term, and/or in parallel with other supply opportunities.

9. REFERENCES

- Carollo. 2017. City of Santa Barbara Potable Reuse Feasibility Study. March 2017
- CH2M Hill. 1991. MWD and MSD Water Reclamation Study.
- Hoover, M.F. 1980. Safe Yield Evaluation of the Montecito Basin and Toro Canyon Area: prepared for the Montecito Water District, 40 p.
- Montecito Sanitary District (MSD). 2016. NPDES Monitoring Program 2015 Annual Summary Report.
- Montecito Sanitary District (MSD). 2017. NPDES Monitoring Program 2016 Annual Summary Report.
- Montecito Sanitary District (MSD). 2018. NPDES Monitoring Program 2017 Annual Summary Report.
- Montecito Water District (MWD). May 2017. Urban Water Management Plan Update.
- MWD. 2014. Potential Recycled Water Opportunities – Wastewater Quality Report Memorandum.
- MWD. 2014. Water Supply Reliability – Overview of Potential Recycled Water Opportunities Memorandum.
- Olivieri, A.W., J. Crook, M.A. Anderson, R.J. Bull, J.E. Drewes, C.N. Haas, W. Jakubowski, P.L. McCarty, K.L. Nelson, J.B. Rose, D.L. Sedlak, and T.J. Wade. 2016. Expert Panel Final Report: Evaluation of the Feasibility of Developing Uniform Water Recycling Criteria for Direct Potable Reuse. August 2016.
http://www.waterboards.ca.gov/drinking_water/certlic/drinkingwater/rw_dpr_criteria.shtml
- Regional Water Quality Control Board, Central Coast Region (RWQCB). 2012. Waste Discharge Requirements for the Montecito Sanitary District Wastewater Treatment Facility, Santa Barbara County
- Regional Water Quality Control Board, Central Coast Region (RWQCB). 2013. Waste Discharge Requirements for the Summerland Sanitary District Wastewater Treatment Plant, Santa Barbara County
- RWQCB. 1993. Water Quality Control Plan for the Central Coastal Basin.
- RMC Water and Environment (RMC). 2013. South Coast Recycled Water Development Plan.
- Santa Barbara County. 2012. Santa Barbara County 2011 Groundwater Report.
- State Water Resources Control Board (SWRCB). Geotracker. Retrieved from <http://geotracker.waterboards.ca.gov/>
- Summerland Sanitary District (SSD). 2016. NPDES Monitoring Program 2015 Annual Report.
- Summerland Sanitary District (SSD). 2017. NPDES Monitoring Program 2016 Annual Report.

APPENDIX A: NON-POTABLE DEMAND ESTIMATES

APPENDIX B: ALTERNATIVES, DETAILED COST ESTIMATES

**Montecito Water District Recycled Water Facilities Plan
Initial Alternatives Screening
Summary**

**ADMIN DRAFT
11/1/2018**

Non-Potable Project Alternatives	Source	Yield	Trmt	Pipe	Total
		AFY	MGD	LF	\$/AF
MSD Supply Alternatives					
NPR MSD1: Santa Barbara Cemetery	MSD	80	0.14	700	\$2,300
NPR MSD2: NPR 1 + Biltmore Extension	MSD	112	0.20	4,400	\$2,600
NPR MSD3: NPR 2 + Golf Courses Extension	MSD	367	0.54	21,000	\$2,900
NPR 3 Extensions (MSD or City)					
NPR MSD3a: NPR 3 to Manning Park / Mont. Union	MSD	371	0.54	25,500	\$3,100
NPR MSD3b: NPR 3a to Westmont / Cold Spring	MSD	390	0.54	44,100	\$3,900
NPR MSD3c: NPR 3 to Agriculture	MSD	404	0.54	30,400	\$3,200
City Supply Alternatives					
NPR SB1: Santa Barbara Cemetery	City*	80	N/A	6,900	\$3,800
NPR SB2: NPR 1 + Biltmore Extension	City*	112	N/A	10,600	\$4,200
NPR SB3: NPR 2 + Golf Courses Extension	City*	367	N/A	27,200	\$4,300
SSD Supply Alternatives					
NPR SSD1: Summerland WWTP, Local Irrigation	SSD	4	0.01	2,200	\$18,300
NPR SSD2: Summerland WWTP, Max Irrigation	SSD	70	0.10	9,700	\$3,800

Potable Reuse Project Alternatives	Source	Yield	AWT Capacity	Pipe	Injection Wells	Total
		AFY	MGD	LF	#	\$/AF
Montecito Basin GWA						
IPR MSD1: Montecito Basin GWA, MSD	MSD	540	0.5	26,500	4	\$3,800
IPR MSD1 & NPR MSD3 (Golf Courses), MSD	MSD	550	0.5	26,500	4	\$3,700
IPR SB1a: Montecito Basin GWA, City RW	City RW*	1,100	1.0	35,700	7	\$5,000
IPR SB1b: Montecito Basin GWA, City WW	City WW*	1,100	1.0	41,300	7	\$5,600
IPR MSD/SB1: Montecito Basin GWA, MSD & City RW	MSD & City RW*	1,100	1.0	35,700	7	\$4,500
Toro Canyon Basin GWA						
IPR MSD2: Toro Canyon Basin GWA, MSD	MSD	540	0.5	32,600	4	\$4,000
IPR SSD2: Toro Canyon Basin GWA, SSD	SSD	90	0.08	11,500	1	\$7,100
Carpinteria Basin GWA						
IPR MSD3a: Carpinteria Basin GWA, MSD	MSD	540	0.5	46,400	1	\$4,200
IPR MSD3b: Carpinteria Basin GWA, MSD WW to CSD AWTF (1.5 MGD)	MSD	540	N/A	48,600	1	\$4,500
Direct Potable Reuse						
DPR 1: Raw Water Augmentation at Bella Vista WTP	MSD	540	0.5	31,200		\$4,300
DPR 2: Treated Drinking Water Aug. @ Romero Reservoir	MSD	540	0.5	26,700		\$4,700
DPR 3: Treated Drinking Water Aug. @ Distribution	MSD	540	0.5	6,700		\$4,000
Regional Project Partnership						
IPR 4: Carpinteria GWR Project Partnership (1.0 MGD)	CSD	540				\$2,300
DPR 4: City of Santa Barbara Raw Water Augmentation	City WW	540				\$2,900

*Note: Alternatives with City RW as a supply include \$2,600/AF for NPR and IPR projects.

Montecito Water District Recycled Water Facilities Plan
Initial Alternatives Screening

ADMIN DRAFT
11/1/2018

NPR MSD1: Santa Barbara Cemetery						
	Size	Units	Qty	Unit	Unit Cost	Subtotal
Recycled Water Supply						
Montecito WWTP, MF			0.16	MGD	\$2,700,000	434,000
Montecito WWTP, RO			0.07	MGD	\$4,100,000	293,000
Montecito WWTP, UV Disinfection			0.14	MGD	\$460,000	66,000
Recycled Water Storage Tank			140,000	gal	\$1.50	210,000
Recycled Water Distribution						
Pump Station @ Montecito WWTP			30	HP	\$6,500	195,000
Recycled Water Pipes	8	in	700	LF	\$20	112,000
Customer Retrofits			1	site	\$25,000	25,000
Raw Construction Cost						1,340,000
Construction Contingency				25%		340,000
Total Construction Cost						1,680,000
Implementation Cost				25%		420,000
Total Project Cost						2,100,000
Annualized Total Project Cost					0.04465	94,000
Annual O&M Cost						83,000
Total Annualized Cost						177,000
					AFY	80
					\$/AFY	2,300

Annual Operations & Maintenance Cost						Annual O&M
Pumping Energy	AFY	GPM	Lift (ft)	kwh-yr	Unit Cost	
Pump Station @ Montecito WWTP	80	62	209	28,600	\$0.18	5,000
						-
						-
Facilities Maintenance					Construction Cost	Unit Cost
Montecito WWTP, MF				\$434,000	8.0%	35,000
Montecito WWTP, RO				\$293,000	8.0%	23,000
Montecito WWTP, UV Disinfection				\$66,000	8.0%	5,000
Recycled Water Storage Tank				\$210,000	2.0%	4,000
Pump Station @ Montecito WWTP				\$195,000	5.0%	10,000
						-
Recycled Water Pipes				\$112,000	1.0%	1,000
						-
Total Annual Operations & Maintenance Cost						83,000

Pump Station Lift (values in ft)	Start (Elev)	Finish (Elev)	Head Loss	Delivery P	Lift
Pump Station @ Montecito WWTP	15	82	4	139	209

Delivery Pressure: 60 psi

Montecito Water District Recycled Water Facilities Plan
Initial Alternatives Screening

ADMIN DRAFT
11/1/2018

NPR MSD2: NPR 1 + Biltmore Extension						
	Size	Units	Qty	Unit	Unit Cost	Subtotal
Recycled Water Supply						
Montecito WWTP, MF			0.23	MGD	\$2,700,000	609,000
Montecito WWTP, RO			0.10	MGD	\$4,100,000	411,000
Montecito WWTP, UV Disinfection			0.20	MGD	\$460,000	92,000
Recycled Water Storage Tank			100,000	gal	\$1.50	150,000
Recycled Water Distribution						
Pump Station @ Montecito WWTP			40	HP	\$6,500	260,000
Recycled Water Pipes	10	in	700	LF	\$20	140,000
Recycled Water Pipes	6	in	3,700	LF	\$20	444,000
Minor Crossings (Railroad, Creek)			1	LS	\$250,000	250,000
Major Crossings (Highways)				LS	\$750,000	-
Customer Retrofits			5	site	\$25,000	125,000
Raw Construction Cost						2,480,000
Construction Contingency				25%		620,000
Total Construction Cost						3,100,000
Implementation Cost				25%		780,000
Total Project Cost						3,880,000
Annualized Total Project Cost					0.04465	173,000
Annual O&M Cost						111,000
Total Annualized Cost						284,000
					AFY	112
					\$/AFY	2,600

Annual Operations & Maintenance Cost						Annual O&M
Pumping Energy	AFY	GPM	Lift (ft)	kwh-yr	Unit Cost	
Pump Station @ Montecito WWTP	112	87	228	43,800	\$0.18	8,000
						-
						-
Facilities Maintenance					Construction Cost	Unit Cost
Montecito WWTP, MF				\$609,000	8.0%	49,000
Montecito WWTP, RO				\$411,000	8.0%	33,000
	0			\$0	2.0%	-
Recycled Water Storage Tank				\$150,000	2.0%	3,000
Pump Station @ Montecito WWTP				\$260,000	5.0%	13,000
Recycled Water Pipes				\$140,000	1.0%	1,000
Recycled Water Pipes				\$444,000	1.0%	4,000
Total Annual Operations & Maintenance Cost						111,000

Pump Station Lift (values in ft)	Start (Elev)	Finish (Elev)	Head Loss	Delivery P	Lift
Pump Station @ Montecito WWTP	15	82	22	139	228

Delivery Pressure: 60 psi

Montecito Water District Recycled Water Facilities Plan
Initial Alternatives Screening

ADMIN DRAFT
11/1/2018

NPR MSD3: NPR 2 + Golf Courses Extension						
	Size	Units	Qty	Unit	Unit Cost	Subtotal
Recycled Water Supply						
Equalization Tank			100,000	gal	\$1.50	150,000
Montecito WWTP, MF			0.60	MGD	\$2,700,000	1,620,000
Montecito WWTP, RO			0.27	MGD	\$4,100,000	1,107,000
Montecito WWTP, UV Disinfection			0.54	MGD	\$460,000	248,000
Recycled Water Storage Tank			270,000	gal	\$1.50	405,000
Recycled Water Distribution						
Pump Station @ Montecito WWTP			60	HP	\$6,500	390,000
Recycled Water Pipes	12	in	4,400	LF	\$20	1,056,000
Recycled Water Pipes	12	in	16,600	LF	\$20	3,984,000
Minor Crossings (Railroad, Creek)			1	LS	\$250,000	250,000
Major Crossings (Highways)			1	LS	\$750,000	750,000
Customer Retrofits			7	site	\$25,000	175,000
Raw Construction Cost						10,140,000
Construction Contingency				25%		2,540,000
Total Construction Cost						12,680,000
Implementation Cost				25%		3,170,000
Total Project Cost						15,850,000
Annualized Total Project Cost					0.04465	708,000
Annual O&M Cost						355,000
Total Annualized Cost						1,063,000
					AFY	367
					\$/AFY	2,900

Annual Operations & Maintenance Cost						Annual O&M
Pumping Energy	AFY	GPM	Lift (ft)	kwh-yr	Unit Cost	
Recycled Water Distribution	367	285	396	248,500	\$0.18	45,000
						-
						-
Facilities Maintenance					Construction Cost	Unit Cost
Equalization Tank				\$150,000	5.0%	8,000
Montecito WWTP, MF				\$1,620,000	8.0%	130,000
Montecito WWTP, RO				\$1,107,000	8.0%	89,000
Montecito WWTP, UV Disinfection				\$248,000	8.0%	20,000
	0			\$0	2.0%	-
Recycled Water Storage Tank				\$405,000	2.0%	8,000
Pump Station @ Montecito WWTP				\$390,000	1.0%	4,000
Recycled Water Pipes				\$1,056,000	1.0%	11,000
Recycled Water Pipes				\$3,984,000	1.0%	40,000
Total Annual Operations & Maintenance Cost						355,000

Pump Station Lift (values in ft)	Start (Elev)	Finish (Elev)	Head Loss	Delivery P	Lift
Recycled Water Distribution	15	236	36	139	396

Delivery Pressure: 60 psi

Montecito Water District Recycled Water Facilities Plan
Initial Alternatives Screening

ADMIN DRAFT
11/1/2018

NPR MSD3a: NPR 3 to Manning Park / Mont. Union						
	Size	Units	Qty	Unit	Unit Cost	Subtotal
Build off of MSD3						
<i>NPR MSD3 Raw Construction Cost</i>						10,140,000
Recycled Water Distribution						
Recycled Water Pipes	6	in	4,500	LF	\$20	540,000
Minor Crossings (Railroad, Creek)			1	LS	\$250,000	250,000
Major Crossings (Highways)				LS	\$750,000	-
Customer Retrofits			2	site	\$25,000	50,000
Raw Construction Cost						10,980,000
Construction Contingency					25%	2,750,000
Total Construction Cost						13,730,000
Implementation Cost					25%	3,430,000
Total Project Cost						17,160,000
Annualized Total Project Cost					0.04465	766,000
Annual O&M Cost						360,000
Total Annualized Cost						1,126,000
					AFY	371
					\$/AFY	3,100

Annual Operations & Maintenance Cost						Annual O&M
Pumping Energy	AFY	GPM	Lift (ft)	kwh-yr	Unit Cost	
						-
						-
Facilities Maintenance			Construction Cost		Unit Cost	
<i>NPR MSD3 Annual O&M</i>						355,000
Recycled Water Pipes			\$540,000		1.0%	5,000
						-
						-
Total Annual Operations & Maintenance Cost						360,000

Pump Station Lift (values in ft)	Start (Elev)	Finish (Elev)	Head Loss	Delivery P	Lift
	15	170	23	139	316
			Delivery Pressure:	60	psi

Montecito Water District Recycled Water Facilities Plan
Initial Alternatives Screening

ADMIN DRAFT
11/1/2018

NPR MSD3b: NPR 3a to Westmont / Cold Spring						
	Size	Units	Qty	Unit	Unit Cost	Subtotal
Build off of MSD3a						
<i>NPR MSD3a Raw Construction Cost</i>						10,980,000
Recycled Water Distribution						
Pump Station No. 2 (Booster)			60	HP	\$6,500	390,000
Recycled Water Pipes	6	in	18,600	LF	\$20	2,232,000
Minor Crossings (Railroad, Creek)			1	LS	\$250,000	250,000
Major Crossings (Highways)			1	LS	\$750,000	750,000
Customer Retrofits			2	site	\$25,000	50,000
Raw Construction Cost						14,650,000
Construction Contingency						25% 3,660,000
Total Construction Cost						18,310,000
Implementation Cost						25% 4,580,000
Total Project Cost						22,890,000
Annualized Total Project Cost					0.04465	1,022,000
Annual O&M Cost						459,000
Total Annualized Cost						1,481,000
					AFY	390
					\$/AFY	3,900

Annual Operations & Maintenance Cost						Annual O&M
Pumping Energy	AFY	GPM	Lift (ft)	kwh-yr	Unit Cost	
Pump Station No. 2 (Booster)	420	327	435	312,500	\$0.18	57,000
Facilities Maintenance						
<i>NPR MSD3a Annual O&M</i>						360,000
Pump Station No. 2 (Booster)				\$390,000	5.0%	20,000
Recycled Water Pipes				\$2,232,000	1.0%	22,000
Total Annual Operations & Maintenance Cost						459,000

Pump Station Lift (values in ft)	Start (Elev)	Finish (Elev)	Head Loss	Delivery P	Lift
Pump Station	15	653	93	139	870
				Lift per PS	435
			Delivery Pressure:	60	psi

Montecito Water District Recycled Water Facilities Plan
Initial Alternatives Screening

ADMIN DRAFT
11/1/2018

NPR MSD3c: NPR 3 to Agriculture						
	Size	Units	Qty	Unit	Unit Cost	Subtotal
Build off of MSD3						
<i>NPR MSD3 Raw Construction Cost</i>						10,140,000
Recycled Water Distribution						
Pump Station No. 2 (Booster)			50	HP	\$6,500	325,000
Recycled Water Pipes	6	in	9,400	LF	\$20	1,128,000
Minor Crossings (Railroad, Creek)			1	LS	\$250,000	250,000
Major Crossings (Highways)				LS	\$750,000	-
Customer Retrofits			1	site	\$25,000	25,000
Raw Construction Cost						11,870,000
Construction Contingency					25%	2,970,000
Total Construction Cost						14,840,000
Implementation Cost					25%	3,710,000
Total Project Cost						18,550,000
Annualized Total Project Cost					0.04465	828,000
Annual O&M Cost						426,000
Total Annualized Cost						1,254,000
					AFY	404
					\$/AFY	3,200

Annual Operations & Maintenance Cost						Annual O&M
Pumping Energy	AFY	GPM	Lift (ft)	kwh-yr	Unit Cost	
Pump Station No. 2 (Booster)	404	314	353	244,300	\$0.18	44,000
					Construction Cost	Unit Cost
<i>NPR MSD3 Annual O&M</i>						355,000
Pump Station No. 2 (Booster)			\$325,000		5.0%	16,000
Recycled Water Pipes			\$1,128,000		1.0%	11,000
Total Annual Operations & Maintenance Cost						426,000

Pump Station Lift (values in ft)	Start (Elev)	Finish (Elev)	Head Loss	Delivery P	Lift
Pump Stations (2)	15	670	28	23	706
					353
			Delivery Pressure:	10	psi

Montecito Water District Recycled Water Facilities Plan
Initial Alternatives Screening

ADMIN DRAFT
11/1/2018

NPR SB1: Santa Barbara Cemetery

	Size	Units	Qty	Unit	Unit Cost	Subtotal	
Recycled Water Supply							
Recycled Water Pipes from Santa Barbara	8	in	6,200	LF	\$20	992,000	
Recycled Water Distribution							
<i>Pressure from City's RW system is assumed to be sufficient to meet MWD RW customer needs</i>							
Recycled Water Pipes	8	in	700	LF	\$20	112,000	
Major Crossing				LS	\$250,000	-	
Customer Retrofits			1	site	\$25,000	25,000	
Raw Construction Cost						1,130,000	
Construction Contingency						25%	280,000
Total Construction Cost						1,410,000	
Implementation Cost						25%	350,000
Total Project Cost						1,760,000	
Annualized Total Project Cost						0.04465	79,000
Annual O&M Cost							219,000
Total Annualized Cost						298,000	
						AFY	80
						\$/AFY	3,800

Annual Operations & Maintenance Cost						Annual O&M
Pumping Energy	AFY	GPM	Lift (ft)	kwh-yr	Unit Cost	
			Yield	Unit	Unit Cost	
City of Santa Barbara, RW Purchase, NPR			80	AF	\$2,600	208,000
Facilities Maintenance						
			Construction Cost		Unit Cost	
Recycled Water Pipes from Santa Barbara			\$992,000		1.0%	10,000
						-
Recycled Water Pipes			\$112,000		1.0%	1,000
						-
Total Annual Operations & Maintenance Cost						219,000

Pump Station Lift (values in ft)	Start (Elev)	Finish (Elev)	Head Loss	Delivery P	Lift
	0	15	82	4	139

Delivery Pressure: 60 psi

Montecito Water District Recycled Water Facilities Plan
Initial Alternatives Screening

ADMIN DRAFT
11/1/2018

NPR SB2: NPR 1 + Biltmore Extension							
	Size	Units	Qty	Unit	Unit Cost	Subtotal	
Recycled Water Supply							
Recycled Water Pipes from Santa Barbara	10	in	6,200	LF	\$20	1,240,000	
Recycled Water Distribution							
<i>Pressure from City's RW system is assumed to be sufficient to meet MWD RW customer needs</i>							
Recycled Water Pipes	10	in	700	LF	\$20	140,000	
Recycled Water Pipes	6	in	3,700	LF	\$20	444,000	
Minor Crossings (Railroad, Creek)			1	LS	\$250,000	250,000	
Major Crossings (Highways)				LS	\$750,000	-	
Customer Retrofits			5	site	\$25,000	125,000	
Raw Construction Cost						2,200,000	
Construction Contingency					25%	550,000	
Total Construction Cost						2,750,000	
Implementation Cost					25%	690,000	
Total Project Cost						3,440,000	
Annualized Total Project Cost					0.04465	154,000	
Annual O&M Cost						309,000	
Total Annualized Cost						463,000	
					AFY	112	
					\$/AFY	4,200	

Annual Operations & Maintenance Cost						Annual O&M
Pumping Energy	AFY	GPM	Lift (ft)	kwh-yr	Unit Cost	
			Yield	Unit	Unit Cost	
City of Santa Barbara, RW Purchase, NPR			112	AF	\$2,600	292,000
Facilities Maintenance						
			Construction Cost		Unit Cost	
Recycled Water Pipes from Santa Barbara			\$1,240,000		1.0%	12,000
						-
Recycled Water Pipes			\$140,000		1.0%	1,000
Recycled Water Pipes			\$444,000		1.0%	4,000
						-
Total Annual Operations & Maintenance Cost						309,000

Pump Station Lift (values in ft)	Start (Elev)	Finish (Elev)	Head Loss	Delivery P	Lift	
	0	15	82	4	139	209

Delivery Pressure: 60 psi

Montecito Water District Recycled Water Facilities Plan
Initial Alternatives Screening

ADMIN DRAFT
11/1/2018

NPR SB3: NPR 2 + Golf Courses Extension							
	Size	Units	Qty	Unit	Unit Cost	Subtotal	
Recycled Water Supply							
Recycled Water Pipes from Santa Barbara	12	in	6,200	LF	\$20	1,488,000	
Recycled Water Distribution							
<i>Pressure from City's RW system is assumed to be sufficient to meet MWD RW customer needs</i>							
Recycled Water Pipes	12	in	4,400	LF	\$20	1,056,000	
Recycled Water Pipes	12	in	16,600	LF	\$20	3,984,000	
Minor Crossings (Railroad, Creek)			1	LS	\$250,000	250,000	
Major Crossings (Highways)			1	LS	\$750,000	750,000	
Customer Retrofits			7	site	\$25,000	175,000	
Raw Construction Cost						7,700,000	
Construction Contingency					25%	1,930,000	
Total Construction Cost						9,630,000	
Implementation Cost					25%	2,410,000	
Total Project Cost						12,040,000	
Annualized Total Project Cost					0.04465	538,000	
Annual O&M Cost						1,020,000	
Total Annualized Cost						1,558,000	
					AFY	367	
					\$/AFY	4,300	

Annual Operations & Maintenance Cost						Annual O&M
Pumping Energy	AFY	GPM	Lift (ft)	kwh-yr	Unit Cost	
			Yield	Unit	Unit Cost	
City of Santa Barbara, RW Purchase, NPR			367	AF	\$2,600	954,000
Facilities Maintenance						
			Construction Cost		Unit Cost	
Recycled Water Pipes from Santa Barbara			\$1,488,000		1.0%	15,000
Recycled Water Pipes			\$1,056,000		1.0%	11,000
Recycled Water Pipes			\$3,984,000		1.0%	40,000
						-
Total Annual Operations & Maintenance Cost						1,020,000

Pump Station Lift (values in ft)	Start (Elev)	Finish (Elev)	Head Loss	Delivery P	Lift
	0	15	82	22	139
					228

Delivery Pressure: 60 psi

Montecito Water District Recycled Water Facilities Plan
Initial Alternatives Screening

ADMIN DRAFT
11/1/2018

NPR SSD1: Summerland WWTP, Local Irrigation						
	Size	Units	Qty	Unit	Unit Cost	Subtotal
Recycled Water Supply						
Summerland WWTP, MF			0.01	MGD	\$2,700,000	27,000
Summerland WWTP, RO			0.004	MGD	\$4,100,000	14,000
Summerland WWTP, UV Disinfection			0.01	MGD	\$460,000	5,000
Recycled Water Storage Tank			10,000	gal	\$1.50	15,000
Recycled Water Distribution						
Pump Station @ Summerland WWTP			10	HP	\$6,500	65,000
Recycled Water Pipes	6	in	2,200	LF	\$20	264,000
Minor Crossings (Railroad, Creek)			2	LS	\$250,000	500,000
Major Crossings (Highways)				LS	\$750,000	-
Customer Retrofits			1	site	\$25,000	25,000
Raw Construction Cost						920,000
Construction Contingency				25%		230,000
Total Construction Cost						1,150,000
Implementation Cost				25%		290,000
Total Project Cost						1,440,000
Annualized Total Project Cost					0.04465	64,000
Annual O&M Cost						9,000
Total Annualized Cost						73,000
					AFY	4
					\$/AFY	18,300

Annual Operations & Maintenance Cost						Annual O&M
Pumping Energy	AFY	GPM	Lift (ft)	kwh-yr	Unit Cost	
Pump Station @ Summerland WWTP	4	3	162	1,100	\$0.18	200
						-
						-
Facilities Maintenance					Construction Cost	Unit Cost
Summerland WWTP, MF			\$27,000		8.0%	2,000
Summerland WWTP, UV Disinfection			\$5,000		8.0%	400
0			\$0		2.0%	-
Pump Station @ Summerland WWTP			\$65,000		5.0%	3,000
						-
Recycled Water Pipes			\$264,000		1.0%	3,000
						-
						-
Total Annual Operations & Maintenance Cost						8,600

Pump Station Lift (values in ft)	Start (Elev)	Finish (Elev)	Head Loss	Delivery P	
				Delivery P	Lift
Pump Station @ Summerland WWTP	51	63	11	139	162

Delivery Pressure: 60 psi

Montecito Water District Recycled Water Facilities Plan
Initial Alternatives Screening

ADMIN DRAFT
11/1/2018

NPR SSD2: Summerland WWTP, Max Irrigation						
	Size	Units	Qty	Unit	Unit Cost	Subtotal
Recycled Water Supply						
Summerland WWTP, MF			0.10	MGD	\$2,700,000	270,000
Summerland WWTP, RO			0.035	MGD	\$4,100,000	144,000
Summerland WWTP, UV Disinfection			0.10	MGD	\$460,000	46,000
Recycled Water Storage Tank			100,000	gal	\$1.50	150,000
Recycled Water Distribution						
Pump Station @ Summerland WWTP			20	HP	\$6,500	130,000
Recycled Water Pipes	6	in	9,700	LF	\$20	1,164,000
Minor Crossings (Railroad, Creek)			1	LS	\$250,000	250,000
Major Crossings (Highways)			1	LS	\$750,000	750,000
Customer Retrofits			3	site	\$25,000	75,000
Raw Construction Cost						2,900,000
Construction Contingency				25%		730,000
Total Construction Cost						3,630,000
Implementation Cost				25%		910,000
Total Project Cost						4,540,000
Annualized Total Project Cost					0.04465	203,000
Annual O&M Cost						64,000
Total Annualized Cost						267,000
					AFY	70
					\$/AFY	3,800

Annual Operations & Maintenance Cost						Annual O&M
Pumping Energy	AFY	GPM	Lift (ft)	kwh-yr	Unit Cost	
Pump Station @ Summerland WWTP	70	55	199	24,000	\$0.18	4,000
						-
						-
Facilities Maintenance					Construction Cost	Unit Cost
Summerland WWTP, MF				\$270,000	8.0%	22,000
Summerland WWTP, RO				\$144,000	8.0%	12,000
Summerland WWTP, UV Disinfection				\$46,000	8.0%	4,000
Recycled Water Storage Tank				\$150,000	2.0%	3,000
Pump Station @ Summerland WWTP				\$130,000	5.0%	7,000
						-
Recycled Water Pipes				\$1,164,000	1.0%	12,000
						-
						-
Total Annual Operations & Maintenance Cost						64,000

Pump Station Lift (values in ft)	Start (Elev)	Finish (Elev)	Head Loss	Delivery P	Lift
Pump Station @ Summerland WWTP	51	63	49	139	199
			Delivery Pressure:	60	psi

Montecito Water District Recycled Water Facilities Plan
Initial Alternatives Screening

ADMIN DRAFT
11/1/2018

IPR MSD1: Montecito Basin GWA, MSD

	Size	Units	Qty	Unit	Unit Cost	Subtotal	
AWTF							
Equalization Storage			100,000	gal	\$1.50	150,000	
MF			0.6	MGD	\$2,700,000	1,620,000	
RO			0.5	MGD	\$4,100,000	1,968,000	
UV AOP			0.5	MGD	\$3,300,000	1,584,000	
Recycled Water Distribution							
Pump Station No. 1 @ AWTF			40	HP	\$6,500	260,000	
Recycled Water Pipes	8	in	22,500	LF	\$20	3,600,000	
Recycled Water Pipes	6	in	4,000	LF	\$20	480,000	
Minor Crossings (Railroad, Creek)			1	LS	\$250,000	250,000	
Major Crossings (Highways)			1	LS	\$750,000	750,000	
Injection Well			4	per well	\$1,000,000	4,000,000	
Monitoring Well			4	per well	\$250,000	1,000,000	
New Potable Well			-	per well	\$1,000,000	-	
Raw Construction Cost						15,660,000	
Construction Contingency						25%	3,920,000
Total Construction Cost						19,580,000	
Implementation Cost						30%	5,870,000
Total Project Cost						25,450,000	
Annualized Total Project Cost					0.04465	1,136,000	
Annual O&M Cost						911,000	
Total Annualized Cost						2,047,000	
						AFY	540
						\$/AFY	3,800

Annual Operations & Maintenance Cost						Annual O&M
	AFY	GPM	Lift (ft)	kwh-yr	Unit Cost	
Pump Station No. 1 @ AWTF	540	420	348	321,200	\$0.18	58,000
Groundwater Pumping			540	AF	\$50	27,000
			Construction Cost		Unit Cost	
Equalization Storage			\$150,000		5.0%	8,000
AWTF			\$5,172,000		8.0%	414,000
Pump Station No. 1 @ AWTF			\$260,000		5.0%	13,000
Recycled Water Pipes			\$3,600,000		1.0%	36,000
Recycled Water Pipes			\$480,000		1.0%	5,000
Injection Well			\$4,000,000		5.0%	200,000
Monitoring Well			\$1,000,000		5.0%	50,000
New Potable Well			\$0		5.0%	-
Monitoring			1	LS	\$100,000	100,000
Total Annual Operations & Maintenance Cost						911,000

Pump Station Lift (values in ft)	Start (Elev)	Finish (Elev)	Head Loss	Delivery P	Lift
Pump Station No. 1 @ AWTF	15	260	80	23	348

Delivery Pressure: 10 psi

Montecito Water District Recycled Water Facilities Plan
Initial Alternatives Screening

ADMIN DRAFT
11/1/2018

IPR MSD1 & NPR MSD3 (Golf Courses), MSD							
	Size	Units	Qty	Unit	Unit Cost	Subtotal	
AWTF							
Equalization Storage			300,000	gal	\$1.50	450,000	
MF/UF			0.6	MGD	\$2,700,000	1,620,000	
RO			0.5	MGD	\$4,100,000	1,968,000	
UV AOP			0.5	MGD	\$3,300,000	1,584,000	
Recycled Water Distribution							
Pump Station No. 1 @ AWTF			40	HP	\$6,500	260,000	
Recycled Water Pipes	12	in	4,400	LF	\$20	1,056,000	
Recycled Water Pipes	12	in	16,600	LF	\$20	3,984,000	
Recycled Water Pipes	6	in	4,000	LF	\$20	480,000	
Minor Crossings (Railroad, Creek)			1	LS	\$250,000	250,000	
Major Crossings (Highways)			1	LS	\$750,000	750,000	
Injection Well			4	per well	\$1,000,000	4,000,000	
Monitoring Well			4	per well	\$250,000	1,000,000	
New Potable Well			-	per well	\$1,000,000	-	
Raw Construction Cost						17,400,000	
Construction Contingency						25%	4,350,000
Total Construction Cost						21,750,000	
Implementation Cost						30%	6,530,000
Total Project Cost						28,280,000	
Annualized Total Project Cost					0.04465	1,263,000	
Annual O&M Cost						758,000	
Total Annualized Cost						2,021,000	
					AFY	550	
					\$/AFY	3,700	

Annual Operations & Maintenance Cost						Annual O&M
Pumping Energy	AFY	GPM	Lift (ft)	kwh-yr	Unit Cost	
Pump Station No. 1 @ AWTF	550	428	331	311,600	\$0.18	56,000
Groundwater Pumping			269	AF	\$50	13,440
			Construction Cost		Unit Cost	
Equalization Storage			\$450,000		5.0%	23,000
AWTF			\$4,038,000	80.0%	8.0%	258,000
Pump Station No. 1 @ AWTF			\$260,000		5.0%	13,000
Recycled Water Pipes			\$3,984,000		1.0%	40,000
Recycled Water Pipes			\$480,000		1.0%	5,000
Injection Well			\$4,000,000		5.0%	200,000
Monitoring Well			\$1,000,000		5.0%	50,000
New Potable Well			\$0		5.0%	-
Monitoring			1	LS	\$100,000	100,000
Total Annual Operations & Maintenance Cost						758,440

Pump Station Lift (values in ft)	Start (Elev)	Finish (Elev)	Head Loss	Delivery P	Lift
Pump Station No. 1 @ AWTF	15	260	63	23	331
				Delivery Pressure:	10 psi

Montecito Water District Recycled Water Facilities Plan
Initial Alternatives Screening

ADMIN DRAFT
11/1/2018

IPR SB1a: Montecito Basin GWA, City RW

	Size	Units	Qty	Unit	Unit Cost	Subtotal
Recycled Water Pipe from Santa Barbara	16	in	6,200	LF	\$20	1,984,000
AWTF						
Equalization Storage			630,000	gal	\$1.50	945,000
MF/UF			1.3	MGD		-
RO			1.0	MGD	\$4,100,000	4,100,000
UV AOP			1.0	MGD	\$3,300,000	3,300,000
Recycled Water Distribution						
Pump Station No. 1 @ AWTF			80	HP	\$6,500	520,000
Recycled Water Pipes	12	in	22,500	LF	\$20	5,400,000
Recycled Water Pipes	6	in	7,000	LF	\$20	840,000
Minor Crossings (Railroad, Creek)			1	LS	\$250,000	250,000
Major Crossings (Highways)			1	LS	\$750,000	750,000
Injection Well			7	per well	\$1,000,000	7,000,000
Monitoring Well			4	per well	\$250,000	1,000,000
New Potable Well			-	per well	\$1,000,000	-
Raw Construction Cost						26,090,000
Construction Contingency				25%		6,520,000
Total Construction Cost						32,610,000
Implementation Cost				30%		9,780,000
Total Project Cost						42,390,000
Annualized Total Project Cost					0.04465	1,893,000
Annual O&M Cost						3,596,000
Total Annualized Cost						5,489,000
					AFY	1,100
					\$/AFY	5,000

Annual Operations & Maintenance Cost						Annual O&M
Pumping Energy	AFY	GPM	Lift (ft)	kwh-yr	Unit Cost	
Pump Station No. 1 @ AWTF	1,100	856	336	631,800	\$0.18	114,000
Groundwater Pumping			1,100	AF	\$50	55,000
City of Santa Barbara, RW Purchase, IPR			1,100	AF	\$2,000	2,200,000
			Construction Cost		Unit Cost	
Equalization Storage				\$945,000	5.0%	47,000
AWTF				\$7,400,000	8.0%	592,000
Pump Station No. 1 @ AWTF				\$520,000	5.0%	26,000
Recycled Water Pipes				\$6,240,000	1.0%	62,000
Injection Well				\$7,000,000	5.0%	350,000
Monitoring Well				\$1,000,000	5.0%	50,000
New Potable Well				\$0	5.0%	-
Monitoring			1	LS	\$100,000	100,000
Total Annual Operations & Maintenance Cost						3,596,000

Pump Station Lift (values in ft)	Start (Elev)	Finish (Elev)	Head Loss	Delivery P	Lift
Pump Station No. 1 @ AWTF	15	260	68	23	336

Delivery Pressure: 10 psi

Montecito Water District Recycled Water Facilities Plan
Initial Alternatives Screening

ADMIN DRAFT
11/1/2018

IPR SB1b: Montecito Basin GWA, City WW

	Size	Units	Qty	Unit	Unit Cost	Subtotal
Equalization Storage @ City WWTP			650,000	gal	\$1.50	975,000
Pump Station No. 1 @ City WWTP			30	HP	\$6,500	195,000
Secondary Wastewater Pipe from Santa Barbara	16	in	11,800	LF	\$20	3,776,000
AWTF						
MF/UF			1.3	MGD	\$2,700,000	3,510,000
RO			1.0	MGD	\$4,100,000	4,264,000
UV AOP			1.0	MGD	\$3,300,000	3,432,000
Recycled Water Distribution						
Pump Station No. 2 @ AWTF			90	HP	\$6,500	585,000
Recycled Water Pipes	12	in	22,500	LF	\$20	5,400,000
Recycled Water Pipes	6	in	7,000	LF	\$20	840,000
Minor Crossings (Railroad, Creek)			1	LS	\$250,000	250,000
Major Crossings (Highways)			1	LS	\$750,000	750,000
Injection Well			7	per well	\$1,000,000	7,000,000
Monitoring Well			4	per well	\$250,000	1,000,000
New Potable Well			-	per well	\$1,000,000	-
Raw Construction Cost						30,810,000
Construction Contingency				25%		7,700,000
Total Construction Cost						38,510,000
Implementation Cost				30%		11,550,000
Total Project Cost						50,060,000
Annualized Total Project Cost					0.04465	2,235,000
Annual O&M Cost						3,915,000
Total Annualized Cost						6,150,000
					AFY	1,100
					\$/AFY	5,600

Annual Operations & Maintenance Cost						Annual O&M
Pumping Energy	AFY	GPM	Lift (ft)	kwh-yr	Unit Cost	
Pump Station No. 1 @ City WWTP	1,375	1,069	200	470,600	\$0.18	85,000
Pump Station No. 2 @ AWTF	1,100	856	336	631,800	\$0.18	114,000
Groundwater Pumping			1,100	AF	\$50	55,000
City of Santa Barbara, RW Purchase, IPR			1,100	AF	\$2,000	2,200,000
				Construction Cost	Unit Cost	
Equalization Storage @ City WWTP				\$975,000	5.0%	49,000
AWTF				\$11,206,000	8.0%	896,000
Pump Station No. 1 @ City WWTP				\$195,000	5.0%	10,000
Pump Station No. 2 @ AWTF				\$585,000	5.0%	29,000
Recycled Water Pipes				\$6,240,000	1.0%	62,000
Injection Well				\$7,000,000	5.0%	350,000
Monitoring Well				\$1,000,000	5.0%	50,000
Monitoring			1	LS	\$100,000	100,000
Total Annual Operations & Maintenance Cost						3,915,000

Pump Station Lift (values in ft)	Start (Elev)	Finish (Elev)	Head Loss	Delivery P	Lift
Pump Station No. 2 @ AWTF	15	260	68	23	336

Delivery Pressure: 10 psi

Montecito Water District Recycled Water Facilities Plan
Initial Alternatives Screening

ADMIN DRAFT
11/1/2018

IPR MSD/SB1: Montecito Basin GWA, MSD & City RW						
	Size	Units	Qty	Unit	Unit Cost	Subtotal
Recycled Water Pipes from Santa Barbara	12	in	6,200	LF	\$20	1,488,000
AWTF						
Equalization Storage			650,000	gal	\$1.50	975,000
MF/UF			1.3	MGD	\$2,700,000	3,510,000
RO			1.0	MGD	\$4,100,000	4,264,000
UV AOP			1.0	MGD	\$3,300,000	3,432,000
Recycled Water Distribution						
Pump Station No. 1 @ AWTF			90	HP	\$6,500	585,000
Recycled Water Pipes	12	in	22,500	LF	\$20	5,400,000
Recycled Water Pipes	6	in	7,000	LF	\$20	840,000
Minor Crossings (Railroad, Creek)			1	LS	\$250,000	250,000
Major Crossings (Highways)			1	LS	\$750,000	750,000
Injection Well			7	per well	\$1,000,000	7,000,000
Monitoring Well			4	per well	\$250,000	1,000,000
New Potable Well			-	per well	\$1,000,000	-
Raw Construction Cost						28,010,000
Construction Contingency				25%		7,000,000
Total Construction Cost						35,010,000
Implementation Cost				30%		10,500,000
Total Project Cost						45,510,000
Annualized Total Project Cost					0.04465	2,032,000
Annual O&M Cost						2,832,000
Total Annualized Cost						4,864,000
					AFY	1,100
					\$/AFY	4,500

Annual Operations & Maintenance Cost						Annual O&M
Pumping Energy	AFY	GPM	Lift (ft)	kwh-yr	Unit Cost	
Pump Station No. 1 @ AWTF	1,100	856	357	671,300	\$0.18	121,000
Groundwater Pumping			1,100	AF	\$50	55,000
City of Santa Barbara, RW Purchase, IPR			560	AF	\$2,000	1,120,000
			Construction Cost		Unit Cost	
Equalization Storage			\$975,000		5.0%	49,000
AWTF			\$11,206,000		8.0%	896,000
Pump Station No. 1 @ AWTF			\$585,000		5.0%	29,000
Recycled Water Pipes			\$6,240,000		1.0%	62,000
Injection Well			\$7,000,000		5.0%	350,000
Monitoring Well			\$1,000,000		5.0%	50,000
New Potable Well			\$0		5.0%	-
Monitoring			1	LS	\$100,000	100,000
Total Annual Operations & Maintenance Cost						2,832,000

Pump Station Lift (values in ft)	Start (Elev)	Finish (Elev)	Head Loss	Delivery P	Lift
Pump Station No. 1 @ AWTF	15	260	89	23	357

Delivery Pressure: 10 psi

Montecito Water District Recycled Water Facilities Plan
Initial Alternatives Screening

ADMIN DRAFT
11/1/2018

IPR MSD2: Toro Canyon Basin GWA, MSD						
	Size	Units	Qty	Unit	Unit Cost	Subtotal
AWTF						
Equalization Storage			300,000	gal	\$1.50	450,000
MF/UF			0.6	MGD	\$2,700,000	1,620,000
RO			0.5	MGD	\$4,100,000	1,968,000
UV AOP			0.5	MGD	\$3,300,000	1,584,000
Recycled Water Distribution						
Pump Station No. 1 @ AWTF			40	HP	\$6,500	260,000
Recycled Water Pipes	8	in	28,600	LF	\$20	4,576,000
Recycled Water Pipes	6	in	4,000	LF	\$20	480,000
Minor Crossings (Railroad, Creek)			1	LS	\$250,000	250,000
Major Crossings (Highways)			1	LS	\$750,000	750,000
Injection Well			4	per well	\$1,000,000	4,000,000
Monitoring Well			4	per well	\$250,000	1,000,000
New Potable Well			-	per well	\$1,000,000	-
Raw Construction Cost						16,940,000
Construction Contingency				25%		4,240,000
Total Construction Cost						21,180,000
Implementation Cost				30%		6,350,000
Total Project Cost						27,530,000
Annualized Total Project Cost					0.04465	1,229,000
Annual O&M Cost						924,000
Total Annualized Cost						2,153,000
					AFY	540
					\$/AFY	4,000

Annual Operations & Maintenance Cost						Annual O&M
Pumping Energy	AFY	GPM	Lift (ft)	kwh-yr	Unit Cost	
Pump Station No. 1 @ AWTF	540	420	276	255,000	\$0.18	46,000
Groundwater Pumping			540	AF	\$50	27,000
				Construction Cost	Unit Cost	
Equalization Storage				\$450,000	5.0%	23,000
AWTF				\$5,172,000	8.0%	414,000
Pump Station No. 1 @ AWTF				\$260,000	5.0%	13,000
Recycled Water Pipes				\$4,576,000	1.0%	46,000
Recycled Water Pipes				\$480,000	1.0%	5,000
Injection Well				\$4,000,000	5.0%	200,000
Monitoring Well				\$1,000,000	5.0%	50,000
New Potable Well				\$0	5.0%	-
Monitoring			1	LS	\$100,000	100,000
Total Annual Operations & Maintenance Cost						924,000

Pump Station Lift (values in ft)	Start (Elev)	Finish (Elev)	Head Loss	Delivery P	Lift
Pump Station No. 1 @ AWTF	15	170	98	23	276

Delivery Pressure: 10 psi

Montecito Water District Recycled Water Facilities Plan
Initial Alternatives Screening

ADMIN DRAFT
11/1/2018

IPR SSD2: Toro Canyon Basin GWA, SSD						
	Size	Units	Qty	Unit	Unit Cost	Subtotal
AWTF						
Equalization Storage			50,000	gal	\$1.50	75,000
MF/UF			0.10	MGD	\$2,700,000	270,000
RO			0.08	MGD	\$4,100,000	328,000
UV AOP			0.08	MGD	\$3,300,000	264,000
Recycled Water Distribution						
Pump Station No. 1 @ WWTP			10	HP	\$6,500	65,000
Recycled Water Pipes	6	in	11,500	LF	\$20	1,380,000
Minor Crossings (Railroad, Creek)			1	LS	\$250,000	250,000
Major Crossings (Highways)			1	LS	\$750,000	750,000
Injection Well			1	per well	\$1,000,000	1,000,000
Monitoring Well			2	per well	\$250,000	500,000
New Potable Well			-	per well	\$1,000,000	-
Raw Construction Cost						4,880,000
Construction Contingency				25%		1,220,000
Total Construction Cost						6,100,000
Implementation Cost				30%		1,830,000
Total Project Cost						7,930,000
Annualized Total Project Cost					0.04465	354,000
Annual O&M Cost						274,000
Total Annualized Cost						628,000
					AFY	90
					\$/AFY	7,100

Annual Operations & Maintenance Cost						Annual O&M
Pumping Energy	AFY	GPM	Lift (ft)	kwh-yr	Unit Cost	
Pump Station No. 1 @ WWTP	90	70	178	27,200	\$0.18	5,000
Groundwater Pumping			90	AF	\$50	4,480
				Construction Cost	Unit Cost	
Equalization Storage				\$75,000	5.0%	4,000
AWTF				\$862,000	8.0%	69,000
Pump Station No. 1 @ WWTP				\$65,000	5.0%	3,000
Recycled Water Pipes				\$1,380,000	1.0%	14,000
Injection Well				\$1,000,000	5.0%	50,000
Monitoring Well				\$500,000	5.0%	25,000
New Potable Well				\$0	5.0%	-
Monitoring			1	LS	\$100,000	100,000
Total Annual Operations & Maintenance Cost						274,480

Pump Station Lift (values in ft)	Start (Elev)	Finish (Elev)	Head Loss	Delivery P	Lift
Pump Station No. 1 @ WWTP	50	170	35	23	178

Delivery Pressure: 10 psi

Montecito Water District Recycled Water Facilities Plan
Initial Alternatives Screening

ADMIN DRAFT
11/1/2018

IPR MSD3a: Carpinteria Basin GWA, MSD

	Size	Units	Qty	Unit	Unit Cost	Subtotal
AWTF						
Equalization Storage			100,000	gal	\$1.50	150,000
MF/UF			0.6	MGD	\$2,700,000	1,620,000
RO			0.5	MGD	\$4,100,000	1,968,000
UV AOP			0.5	MGD	\$3,300,000	1,584,000
Recycled Water Distribution						
Pump Station No. 1 @ WWTP			40	HP	\$6,500	260,000
Recycled Water Pipes	8	in	46,400	LF	\$20	7,424,000
Minor Crossings (Railroad, Creek)			3	LS	\$250,000	750,000
Major Crossings (Highways)			3	LS	\$750,000	2,250,000
Injection Well			1	per well	\$1,500,000	1,500,000
Monitoring Well			2	per well	\$250,000	500,000
New Potable Well			1	per well	\$1,500,000	1,500,000
Raw Construction Cost						19,510,000
Construction Contingency				25%		4,880,000
Total Construction Cost						24,390,000
Implementation Cost				30%		7,320,000
Total Project Cost						31,710,000
Annualized Total Project Cost					0.04465	1,416,000
Annual O&M Cost						842,000
Total Annualized Cost						2,258,000
					AFY	540
					\$/AFY	4,200

Annual Operations & Maintenance Cost						Annual O&M
Pumping Energy	AFY	GPM	Lift (ft)	kwh-yr	Unit Cost	
Pump Station No. 1 @ WWTP	540	420	347	321,000	\$0.18	58,000
			Yield	Unit	Unit Cost	
Carpinteria Water Exchange			540	AF	\$0	-
			Construction Cost		Unit Cost	
Equalization Storage			\$150,000		5.0%	8,000
AWTF			\$5,172,000		8.0%	414,000
Pump Station No. 1 @ WWTP			\$260,000		5.0%	13,000
Recycled Water Pipes			\$7,424,000		1.0%	74,000
						-
Injection Well			\$1,500,000		5.0%	75,000
Monitoring Well			\$500,000		5.0%	25,000
New Potable Well			\$1,500,000		5.0%	75,000
Monitoring			1	LS	\$100,000	100,000
Total Annual Operations & Maintenance Cost						842,000

Pump Station Lift (values in ft)	Start (Elev)	Finish (Elev)	Head Loss	Delivery P	Lift
Pump Station No. 1 @ WWTP	15	200	139	23	347

Delivery Pressure: 10 psi

Montecito Water District Recycled Water Facilities Plan
Initial Alternatives Screening

ADMIN DRAFT
11/1/2018

IPR MSD3b: Carpinteria Basin GWA, MSD WW to CSD AWTF (1.5 MGD)						
CSD WW Conveyance	Size	Units	Qty	Unit	Unit Cost	Subtotal
Equalization Storage			100,000	gal	\$1.50	150,000
Pump Station No. 1 @ WWTP to CSD			50	HP	\$6,500	325,000
Recycled Water Pipes to CSD	10	in	48,600	LF	\$20	9,720,000
Major Crossing			5	EA	\$250,000	1,250,000
AWTF						
MF/UF			33%	MWD %	\$5,063,000	1,688,000
RO			33%	MWD %	\$6,150,000	2,050,000
UV AOP			33%	MWD %	\$4,950,000	1,650,000
Recycled Water Distribution						
Pump Station No. 1 @ CSD			33%	MWD %	\$585,000	195,000
Recycled Water Pipes			33%	MWD %	\$2,191,000	730,000
Recycled Water Pipes to Well			33%	MWD %	\$300,000	100,000
Injection Well			33%	MWD %	\$4,500,000	1,500,000
Monitoring Well			33%	MWD %	\$1,000,000	333,000
New Potable Well			1	EA	\$1,500,000	1,500,000
Raw Construction Cost						21,040,000
Construction Contingency				25%		5,260,000
Total Construction Cost						26,300,000
Implementation Cost				30%		7,890,000
Total Project Cost						34,190,000
Annualized Total Project Cost					0.04465	1,527,000
Annual O&M Cost						887,000
Total Annualized Cost						2,414,000
					AFY	540
					\$/AFY	4,500

Annual Operations & Maintenance Cost						Annual O&M
Pumping Energy	AFY	GPM	Lift (ft)	kwh-yr	Unit Cost	
Pump Station No. 1 @ WWTP to CSD	540	420	354	327,100	\$0.18	59,000
			Yield	Unit	Unit Cost	
Carpinteria Water Exchange			540	AF	\$0	-
			Construction Cost	Unit Cost		
O&M Cost Share from CVWD GWR Project			33%	MWD %	\$1,844,000	615,000
Equalization Storage			\$150,000	5.0%		8,000
Pump Station No. 1 @ WWTP to CSD			\$325,000	5.0%		16,000
Recycled Water Pipes to CSD			\$9,720,000	1.0%		97,000
						-
Injection Well			\$1,500,000	5.0%		75,000
New Potable Well			\$333,000	5.0%		17,000
Total Annual Operations & Maintenance Cost						887,000

Pump Station Lift (values in ft)	Start (Elev)	Finish (Elev)	Head Loss	Delivery P	Lift
Pump Station No. 1 @ WWTP to CSD	15	200	146	23	354

Delivery Pressure: 10 psi

Montecito Water District Recycled Water Facilities Plan
Initial Alternatives Screening

ADMIN DRAFT
11/1/2018

IPR 4: Carpinteria GWR Project Partnership (1.0 MGD)

	Size	Units	Qty	Unit	Unit Cost	Subtotal
AWTF						
Equalization Storage			200,000	gal	\$1.50	300,000
MF/UF			1.2	MGD	\$2,700,000	3,240,000
RO			1.0	MGD	\$4,100,000	3,936,000
UV AOP			1.0	MGD	\$3,300,000	3,168,000
Recycled Water Distribution						
Pump Station No. 1 @ CSD			90	HP	\$6,500	585,000
Recycled Water Pipes to Well	12	in	7,400	LF	\$20	1,776,000
Recycled Water Pipes to Well	10	in	1,000	LF	\$20	200,000
Minor Crossings (Railroad, Creek)				LS	\$250,000	-
Major Crossings (Highways)				LS	\$750,000	-
Injection Well			2	per well	\$1,500,000	3,000,000
Monitoring Well			4	per well	\$250,000	1,000,000
New Potable Well				per well	\$1,500,000	-
Raw Construction Cost						17,210,000
Construction Contingency				25%		4,300,000
Total Construction Cost						21,510,000
Implementation Cost				30%		6,450,000
Total Project Cost						27,960,000
Annualized Total Project Cost					0.04465	1,248,000
Annual O&M Cost						1,169,000
Total Annualized Cost						2,417,000
					AFY	1,080
					\$/AFY	2,300

Annual Operations & Maintenance Cost						Annual O&M
Pumping Energy	AFY	GPM	Lift (ft)	kwh-yr	Unit Cost	
Pump Station No. 1 @ CSD	1,080	840	230	425,700	\$0.18	77,000
			Yield	Unit	Unit Cost	
Carpinteria Water Exchange			1,080	AF	\$0	-
			Construction Cost		Unit Cost	
Equalization Storage			\$300,000		5.0%	15,000
AWTF			\$10,344,000		8.0%	828,000
Pump Station No. 1 @ CSD			\$585,000		5.0%	29,000
Recycled Water Pipes to Well			\$1,776,000		1.0%	18,000
Recycled Water Pipes to Well			\$200,000		1.0%	2,000
Injection Well			\$3,000,000		5.0%	150,000
Monitoring Well			\$1,000,000		5.0%	50,000
Total Annual Operations & Maintenance Cost						1,169,000

Pump Station Lift (values in ft)	Start (Elev)	Finish (Elev)	Head Loss	Delivery P	Lift
Recycled Water Pipes to Well	15	200	22	23	230

Delivery Pressure: 10 psi

Montecito Water District Recycled Water Facilities Plan
Initial Alternatives Screening

ADMIN DRAFT
11/1/2018

DPR 1: Raw Water Augmentation at Bella Vista WTP						
	Size	Units	Qty	Unit	Unit Cost	Subtotal
AWTF+						
Equalization Storage			100,000	gal	\$1.50	150,000
MF/UF			0.6	MGD	\$2,700,000	1,620,000
RO			0.5	MGD	\$4,100,000	1,968,000
UV AOP			0.5	MGD	\$3,300,000	1,584,000
CL2			<i>existing chlorine contact basin is assumed</i>			
Engineered Storage	3	EA	40,000	gal	\$1.50	180,000
Monitoring Equipment			5,172,000	\$	20%	1,034,400
Recycled Water Distribution						
Pump Station No. 1 @ WWTP			50	HP	\$6,500	325,000
Pump Station No. 2 (Booster)			50	HP	\$6,500	325,000
Pump Station No. 3 (Booster)			50	HP	\$6,500	325,000
Recycled Water Pipes	10	in	31,200	LF	\$20	6,240,000
Minor Crossings (Railroad, Creek)			1	LS	\$250,000	250,000
Major Crossings (Highways)			1	LS	\$750,000	750,000
Discharge Structure			1	LS	\$500,000	500,000
Raw Construction Cost						15,250,000
Construction Contingency					25%	3,810,000
Total Construction Cost						19,060,000
Implementation Cost					30%	5,720,000
Total Project Cost						24,780,000
Annualized Total Project Cost					0.04465	1,106,000
Annual O&M Cost						1,163,000
Total Annualized Cost						2,269,000
					AFY	540
					\$/AFY	4,300

Annual Operations & Maintenance Cost						Annual O&M
Pumping Energy	AFY	GPM	Lift (ft)	kwh-yr	Unit Cost	
Pump Station No. 1 @ WWTP	540	420	395	364,600	\$0.18	66,000
Pump Station No. 2 (Booster)	540	420	395	364,600	\$0.18	66,000
Pump Station No. 3 (Booster)	540	420	395	364,600	\$0.18	66,000
			Construction Cost		Unit Cost	
Equalization Storage			\$150,000		5.0%	8,000
AWTF+			\$5,322,000		8.0%	426,000
Engineered Storage			180,000		5.0%	9,000
Monitoring			1	LS	\$250,000	250,000
Pump Station No. 1 @ WWTP			\$325,000		5.0%	16,000
Pump Station No. 2 (Booster)			\$325,000		5.0%	16,000
Pump Station No. 3 (Booster)			\$325,000		5.0%	16,000
Recycled Water Pipes			\$6,240,000		1.0%	62,000
Bella Vista WTP Operations			540	AF	\$300	162,000
Total Annual Operations & Maintenance Cost						1,163,000

Pump Station Lift (values in ft)	Start (Elev)	Finish (Elev)	Head Loss	Delivery P	Lift
Pump Station No. 1 @ WWTP	15	1082	94	23	1184
				Lift per PS	395
			Delivery Pressure:	10	psi

Montecito Water District Recycled Water Facilities Plan
Initial Alternatives Screening

ADMIN DRAFT
11/1/2018

DPR 3: Treated Drinking Water Aug. @ Distribution						
	Size	Units	Qty	Unit	Unit Cost	Subtotal
AWTF++						
Equalization Storage			100,000	gal	\$1.50	150,000
MF/UF			0.6	MGD	\$2,700,000	1,620,000
RO			0.5	MGD	\$4,100,000	1,968,000
UV AOP			0.5	MGD	\$3,300,000	1,584,000
CL2			<i>existing chlorine contact basin is assumed</i>			-
Ozone			0.5	MGD	\$4,400,000	2,112,000
BAC			0.5	MGD	\$590,000	283,000
Engineered Storage	3	EA	120,000	gal	\$1.50	540,000
Monitoring Equipment			7,567,000	\$	20%	1,513,000
Recycled Water Distribution						
Pump Station No. 1 @ WWTP			30	HP	\$6,500	195,000
Recycled Water Pipes	10	in	6,700	LF	\$20	1,340,000
Minor Crossings (Railroad, Creek)			1	LS	\$250,000	250,000
Major Crossings (Highways)			1	LS	\$750,000	750,000
Potable Connection			1	LS	\$500,000	500,000
Raw Construction Cost						12,810,000
Construction Contingency					25%	3,200,000
Total Construction Cost						16,010,000
Implementation Cost					30%	4,800,000
Total Project Cost						20,810,000
Annualized Total Project Cost					0.04465	929,000
Annual O&M Cost						1,201,000
Total Annualized Cost						2,130,000
					AFY	540
					\$/AFY	4,000

Annual Operations & Maintenance Cost						Annual O&M
Pumping Energy	AFY	GPM	Lift (ft)	kwh-yr	Unit Cost	
Pump Station No. 1 @ WWTP	540	420	228	210,900	\$0.18	38,000
						-
			Construction Cost		Unit Cost	
Equalization Storage			\$150,000		5.0%	8,000
AWTF++			7,567,000		8.0%	605,000
Engineered Storage			540,000		5.0%	27,000
Monitoring			1	LS	\$500,000	500,000
						-
Pump Station No. 1 @ WWTP			195,000		5.0%	10,000
Recycled Water Pipes			1,340,000		1.0%	13,000
						-
Total Annual Operations & Maintenance Cost						1,201,000

Pump Station Lift (values in ft)	Start (Elev)	Finish (Elev)	Head Loss	Delivery P	Lift
Pump Station No. 1 @ WWTP	15	200	20	23	228

Delivery Pressure: 10 psi

Montecito Water District Recycled Water Facilities Plan
Initial Alternatives Screening

ADMIN DRAFT
11/1/2018

DPR 4: City of Santa Barbara Raw Water Augmentation

	Size	Units	Qty	Unit	Unit Cost	Subtotal
AWTF++						
Equalization Storage			3,900,000	gal	\$1.50	5,850,000
MF/UF			7.7	MGD	\$2,700,000	20,790,000
Pre-RO UV			6.2	MGD	\$460,000	2,834,000
RO			6.2	MGD	\$4,100,000	25,256,000
UV AOP			6.2	MGD	\$3,300,000	20,328,000
Engineered Storage	3	EA	1,030,000	gal	\$1.50	4,635,000
Monitoring Equipment			69,208,000	\$	10%	6,920,800
Recycled Water Distribution						
Pump Station No. 1 @ WWTP			440	HP	\$6,500	2,860,000
Recycled Water Pipes, 12" Parallel Line	12	in	11,500	LF	\$20	2,760,000
Pump Station No. 2 @ Golf Course			730	HP	\$6,500	4,745,000
Recycled Water Pipes, 16" Line	16	in	14,000	LF	\$20	4,480,000
Minor Crossings (Railroad, Creek)			5	LS	\$250,000	1,250,000
Major Crossings (Highways)			1	LS	\$750,000	750,000
Discharge Structure			1	LS	\$500,000	500,000
Raw Construction Cost						103,460,000
Construction Contingency					25%	25,870,000
Total Construction Cost						129,330,000
Implementation Cost					30%	38,800,000
Total Project Cost						168,130,000
Annualized Total Project Cost					0.04465	7,507,000
Annual O&M Cost						10,217,000
Total Annualized Cost						17,724,000
					AFY	6,300
					\$/AFY	2,900

Annual Operations & Maintenance Cost						Annual O&M
	AFY	GPM	Lift (ft)	kwh-yr	Unit Cost	
Pump Station No. 1 @ WWTP	6,300	4,900	300	3,234,500	\$0.18	582,000
Pump Station No. 2 @ Golf Course	6,300	4,900	505	5,445,800	\$0.18	980,000
				Construction Cost	Unit Cost	
Equalization Storage				\$5,850,000	5.0%	293,000
AWTF+				\$69,208,000	8.0%	5,537,000
Engineered Storage				\$4,635,000	5.0%	232,000
Monitoring			1	LS	\$250,000	250,000
Pump Station No. 1 @ WWTP				\$2,860,000	5.0%	143,000
Recycled Water Pipes, 12" Parallel Line				\$2,760,000	1.0%	28,000
Pump Station No. 2 @ Golf Course				\$4,745,000	5.0%	237,000
Recycled Water Pipes, 16" Line				\$4,480,000	1.0%	45,000
Cater WTP Operations			6300	AF	\$300	1,890,000
Total Annual Operations & Maintenance Cost						10,217,000

Pump Station Lift (values in ft)	Start (Elev)	Finish (Elev)	Head Loss	Delivery P	Lift
	200	640	42	23	505

Delivery Pressure: 10 psi

APPENDIX C: TOP ALTERNATIVES, DETAILED COST ESTIMATES



November 2018

Project: Montecito RW Facilities Plan

Estimate Type: Conceptual Design

Alternative	A	B	C	D
Description	Small NPR	Large NPR	Montecito IPR	Carpinteria IPR
Capital Costs				
2 - Sitework	\$ 788,000	\$ 6,448,000	\$ 7,648,000	Construction Cost Incorporated from the 2016 Carpinteria Recycled Water Facilities Plan; updated to Sep 2018 ENR CCI
3 - Concrete	\$ 117,000	\$ 296,000	\$ 292,000	
4 - Masonry	\$ 136,000	\$ 178,000	\$ 196,000	
5 - Metals	\$ 43,000	\$ 62,000	\$ 95,000	
11 - Equipment	\$ 1,180,000	\$ 1,992,000	\$ 6,819,000	
13 - Special Construction	\$ 493,000	\$ 329,000	\$ 829,000	
15 - Mechanical	\$ 236,000	\$ 399,000	\$ 1,364,000	
16 - Electrical	\$ 236,000	\$ 399,000	\$ 1,364,000	
17 - I&C	\$ 236,000	\$ 399,000	\$ 1,364,000	
Raw Construction Cost	\$ 3,465,000	\$ 10,502,000	\$ 19,971,000	\$ 17,106,000
Construction Contingency	\$ 693,000	\$ 2,100,000	\$ 3,994,000	\$ 4,277,000
Base Construction Cost	\$ 4,158,000	\$ 12,602,000	\$ 23,965,000	\$ 21,383,000
Implementation Costs	\$ 1,041,000	\$ 3,154,000	\$ 7,192,000	\$ 6,415,000
Total Estimated Capital Cost	\$ 5,199,000	\$ 15,756,000	\$ 31,157,000	\$ 27,798,000
Annual Costs				
Annual Cost of Consumables	\$ 34,000	\$ 109,000	\$ 250,000	\$ -
Annual Cost of Power	\$ 34,000	\$ 141,000	\$ 225,000	\$ -
Annual Labor Costs	\$ 125,000	\$ 250,000	\$ 250,000	\$ -
Total Annual O&M	\$ 193,000	\$ 500,000	\$ 725,000	\$ 1,157,000
Annualized Capital Costs				
Annualized Capital Costs	\$ 232,135	\$ 703,504	\$ 1,391,158	\$ 1,241,179
Total Annual O&M	\$ 193,000	\$ 500,000	\$ 725,000	\$ 1,157,000
Total Annualized Cost	\$ 425,135	\$ 1,203,504	\$ 2,116,158	\$ 2,398,179
Project Unit Costs				
Recycled Water Yield (AFY)	80	367	540	1,100
Project Unit Cost (\$/AF)	\$5,300	\$3,300	\$3,900	\$2,200

Notes:

1. Estimated costs are referenced to the September 2018 ENR CCI for Los Angeles; 12002.5
2. Annualized cost are based on a State Revolving Fund financing of 30 years at 2.0% interest rate.

Project: Montecito RW Facilities Plan

Date: November 2018

Project Number: 0011083.00

Alternative: A Small NPR

Prepared by: RM,MMC

Checked by:

Annual Demand 80 AFY

MF Capacity 0.2 MGD

RO Capacity 0.1 MGD

UV Capacity 0.2 MGD

Estimate Type: Conceptual Design

Process Cost Summary by Division

Spec. Division		Subtotal	Notes
2 - Sitework		\$ 788,000	
3 - Concrete		\$ 117,000	
4 - Masonry		\$ 136,000	
5 - Metals		\$ 43,000	
11 - Equipment		\$ 1,180,000	
13 - Special Construction		\$ 493,000	
15 - Mechanical		\$ 236,000	
16 - Electrical		\$ 236,000	
17 - I&C		\$ 236,000	
Raw Construction Subtotal		\$ 3,465,000	
	Construction Contingency 20%	\$ 693,000	
Construction Cost Subtotal		\$ 4,158,000	
	Environmental Documents and Permitting 5%	\$ 208,000	
	Design Services 8%	\$ 333,000	
	Construction Management 8%	\$ 333,000	
	Engineering Services During Construction 4%	\$ 167,000	
Estimated Total Capital Cost		\$ 5,199,000	

Spec. Division / Item	Size	Units	Quantity	Unit	Unit Cost	Total Cost	Notes
2 - Sitework						\$ 788,000	
Mobilization/Demobilization			\$ 3,150,000		10%	\$ 315,000	
Sitework Allowance			1	LS	\$ 100,000	\$ 100,000	
MF Feed Pipeline	6 in		500	LF	\$ 123	\$ 62,000	
Excavation for Equalization			0	CY	\$ 33	\$ -	2' over excavation
Excavation for Pads			400	CY	\$ 33	\$ 14,000	3' depth
Offhaul			400	CY	\$ 10	\$ 4,000	Assumes all excavation is offhauled
Dewatering							
Structural Piles							
Landscaping Allowance			1	LS	\$ 25,000	\$ 25,000	
4" Pipe, MF Backwash	4 in		500	LF	\$ 123	\$ 62,000	
4" Pipe, RO Concentrate	4 in		500	LF	\$ 123	\$ 62,000	
RW Distribution Pipe	8 in		700	LF	\$ 205	\$ 144,000	
3 - Concrete						\$ 117,000	
MF Influent PS Slab			12	CY	\$ 800	\$ 10,000	12 in thick
Treatment Building Slab			71	CY	\$ 800	\$ 57,000	12 in thick
UV System Slab			13	CY	\$ 800	\$ 11,000	12 in thick
Chemical Storage Slab			26	CY	\$ 800	\$ 21,000	12 in thick
RW Tank/PS Slab			22	CY	\$ 800	\$ 18,000	12 in thick

Spec. Division / Item	Size	Units	Quantity	Unit	Unit Cost	Total Cost	Notes
4 - Masonry						\$ 136,000	
CMU Blocks			3,900	SF	\$ 35	\$ 136,000	15 ft height
5 - Metals						\$ 43,000	
CMU Building Roofing			2,900	SF	\$ 15	\$ 43,000	Treatment Building
11 - Equipment						\$ 1,180,000	
MF Feed Pumps							Included in vendor package
MF System	0.2	MGD	1	LS	\$ 423,000	\$ 423,000	AWC Quote (9/28/2018)
RO System	0.1	MGD	1	LS	\$ 230,000	\$ 230,000	TrojanUV Quote (6/19/2018)
UV System	0.2	MGD	1	LS	\$ 653,000	\$ 327,000	50% of equipment cost
Treatment Equipment Installation			50%	LS	\$ 50,000	\$ 50,000	
Chemical Allowance			1	LS	\$ 50,000	\$ 100,000	1 duty + 1 standby
RW Pumps	30	hp	2	EA	\$ 50,000	\$ 50,000	
Pump Install			1	LS	\$ 50,000	\$ 50,000	
13 - Special Construction						\$ 493,000	
MF Feed Storage			1	EA	\$ 223,000	\$ 223,000	20,000 gallons, Means
RW Storage			1	EA	\$ 270,000	\$ 270,000	70,000 gallons, Means
15 - Mechanical						\$ 236,000	
Piping, Valve, Fitting, Supports Allowance		Allowance			20%	\$ 236,000	20% of Division 11 (Equipment)
16 - Electrical						\$ 236,000	
Electrical Allowance					20%	\$ 236,000	20% of Division 11 (Equipment)
17 - I&C						\$ 236,000	
I&C Allowance					20%	\$ 236,000	20% of Division 11 (Equipment)
ANNUAL O&M COSTS							
			Amount	Unit	Value	Cost	
Consumables				Total Consumables	\$	34,000	
Equipment Consumables			\$ 1,180,000		2%	\$ 24,000	2% of Equipment
Electrical Consumables			\$ 236,000		2%	\$ 5,000	2% of Electrical
Instrumentation Consumables			\$ 236,000		2%	\$ 5,000	2% of Instrumentation
Pipeline Consumables			\$ 3,300		1.0%	\$ 100	1% of Pipeline
Power Costs				Total Power	\$	34,000	
Secondary Pumps (MF Feed)			6,800	kwh	\$ 0.18	\$ 2,000	
MF Backwash Pump			24,200	kwh	\$ 0.18	\$ 5,000	
RO High Pressure Pump			22,800	kwh	\$ 0.18	\$ 5,000	
UV System			105,120	kwh	\$ 0.18	\$ 19,000	
RW Distribution Pumps			12,300	kwh	\$ 0.18	\$ 3,000	
Labor Costs				Total Labor	\$	125,000	
Total # Operators			0.5	FTE			
Average Annual Hours per operator			2080	hrs/yr			
Total Operators per year			1040	Total hrs	\$ 120	\$ 125,000	
TOTAL ANNUAL O&M COSTS						\$	193,000

Project: Montecito RW Facilities Plan

Date: November 2018

Project Number: 0011083.00

Alternative: B Large NPR

Prepared by: RM,MMC

Checked by:

Annual Demand 367 AFY

MF Capacity 0.6 MGD

RO Capacity 0.3 MGD

UV Capacity 0.6 MGD

Estimate Type: Conceptual Design

Process Cost Summary by Division

Spec. Division		Subtotal	Notes
2 - Sitework		\$ 6,448,000	
3 - Concrete		\$ 296,000	
4 - Masonry		\$ 178,000	
5 - Metals		\$ 62,000	
11 - Equipment		\$ 1,992,000	
13 - Special Construction		\$ 329,000	
15 - Mechanical		\$ 399,000	
16 - Electrical		\$ 399,000	
17 - I&C		\$ 399,000	
Raw Construction Subtotal		\$ 10,502,000	
	Construction Contingency 20%	\$ 2,100,000	
Construction Cost Subtotal		\$ 12,602,000	
	Environmental Documents and Permitting 5%	\$ 631,000	
	Engineering Services (Design) 8%	\$ 1,009,000	
	Construction Management 8%	\$ 1,009,000	
	Engineering Services During Construction 4%	\$ 505,000	
Estimated Total Capital Cost		\$ 15,756,000	

Spec. Division / Item	Size	Units	Quantity	Unit	Unit Cost	Total Cost	Notes
2 - Sitework						\$ 6,448,000	
Mobilization/Demobilization			\$ 9,816,000		10%	\$ 982,000	
Sitework Allowance			1	LS	\$ 100,000	\$ 100,000	
MF Feed Pipeline	12	in	500	LF	\$ 195	\$ 98,000	
Excavation for Equalization			750	CY	\$ 33	\$ 19,000	2' over excavation
Excavation for Pads			580	CY	\$ 33	\$ 25,000	3' depth
Offhaul			1,400	CY	\$ 10	\$ 14,000	Assumes all excavation is offhauled
Dewatering							
Structural Piles							
Landscaping Allowance			1	LS	\$ 25,000	\$ 25,000	
4" Pipe, MF Backwash	4	in	500	LF	\$ 123	\$ 62,000	
4" Pipe, RO Concentrate	4	in	500	LF	\$ 123	\$ 62,000	
RW Distribution Pipe	12	in	21,000	LF	\$ 241	\$ 5,061,000	
3 - Concrete						\$ 296,000	
Secondary EQ Basin			170	CY	\$ 800	\$ 136,000	18 in thick, 12 inch thick
Treatment Building Slab			110	CY	\$ 800	\$ 88,000	12 in thick
UV System Slab			19	CY	\$ 800	\$ 16,000	12 in thick
RW Tank/PS Slab			30	CY	\$ 800	\$ 24,000	12 in thick
Chemical Storage Slab			40	CY	\$ 800	\$ 32,000	12 in thick

Spec. Division / Item	Size	Units	Quantity	Unit	Unit Cost	Total Cost	Notes
4 - Masonry						\$ 178,000	
CMU Blocks			5,100	SF	\$ 35	\$ 178,000	15 ft height
5 - Metals						\$ 62,000	
CMU Building Roofing			4,200	SF	\$ 15	\$ 62,000	Treatment Building
11 - Equipment						\$ 1,992,000	
MF Feed Pumps	10	hp	0	EA	\$ 37,000	\$ -	Included in vendor package
MF System	0.6	MGD	1	LS	\$ 713,000	\$ 713,000	AWC Quote (9/28/2018)
RO System	0.3	MGD	1	LS	\$ 460,000	\$ 460,000	TrojanUV Quote (6/19/2018)
UV System	0.6	MGD	1	LS	\$ 1,173,000	\$ 587,000	50% of equipment cost
Treatment Equipment Installation			50%	LS	\$ 50,000	\$ 50,000	
Chemical Allowance			1	LS	\$ 66,000	\$ 132,000	1 duty + 1 standby
RW Pumps	110	hp	2	EA	\$ 50,000	\$ 50,000	
Pump Install			1	LS			
13 - Special Construction						\$ 329,000	
RW Storage			1	EA	\$ 329,000	\$ 329,000	200,000 gallons, Means
Hwy 101 Crossing			1	LS	\$ 500,000	\$ 500,000	
15 - Mechanical						\$ 399,000	
Piping, Valve, Fitting, Supports Allowance			Allowance		20%	\$ 399,000	20% of Division 11 (Equipment)
16 - Electrical						\$ 399,000	
Electrical Allowance					20%	\$ 399,000	20% of Division 11 (Equipment)
17 - I&C						\$ 399,000	
I&C Allowance					20%	\$ 399,000	20% of Division 11 (Equipment)
ANNUAL O&M COSTS			Amount	Unit	Value	Cost	
Consumables				Total Consumables		\$ 109,000	
Equipment Consumables			\$ 1,992,000		2%	\$ 40,000	2% of Equipment
Electrical Consumables			\$ 399,000		2%	\$ 8,000	2% of Electrical
Instrumentation Consumables			\$ 399,000		2%	\$ 8,000	2% of Instrumentation
Pipeline Consumables			\$ 5,283,000		1%	\$ 53,000	1% of Pipeline
Power Costs				Total Power		\$ 141,000	
Secondary Pumps (MF Feed)			34,800	kwh	\$ 0.18	\$ 7,000	
MF Backwash Pump			72,600	kwh	\$ 0.18	\$ 14,000	
RO High Pressure Pump			348,600	kwh	\$ 0.18	\$ 63,000	
UV System			210,240	kwh	\$ 0.18	\$ 38,000	
RW Distribution Pumps			104,200	kwh	\$ 0.18	\$ 19,000	
Labor Costs				Total Labor		\$ 250,000	
Total # Operators			1.0	FTE			
Average Annual Hours per operator			2080	hrs/yr			
Total Operators per year			2080	Total hrs	\$ 120	\$ 250,000	
TOTAL ANNUAL O&M COSTS						\$ 500,000	

Project: Montecito RW Facilities Plan

Date: November 2018

Alternative: C Montecito IPR

Project Number: 0011083.00

Prepared by: RM,MMC

Checked by:

Annual Demand 540 AFY

MF Capacity 0.6 MGD

RO Capacity 0.5 MGD

UV Capacity 0.5 MGD

Estimate Type: Conceptual Design

Process Cost Summary by Division

Spec. Division	Subtotal	Notes
2 - Sitework	\$ 7,648,000	
3 - Concrete	\$ 292,000	
4 - Masonry	\$ 196,000	
5 - Metals	\$ 95,000	
11 - Equipment	\$ 6,819,000	
13 - Special Construction	\$ 829,000	
15 - Mechanical	\$ 1,364,000	
16 - Electrical	\$ 1,364,000	
17 - I&C	\$ 1,364,000	
Raw Construction Subtotal	\$ 19,971,000	
Construction Contingency 20%	\$ 3,994,000	
Construction Cost Subtotal	\$ 23,965,000	
Environmental Documents and Permitting 10%	\$ 2,397,000	
Engineering Services (Design) 8%	\$ 1,918,000	
Construction Management 8%	\$ 1,918,000	
Engineering Services During Construction 4%	\$ 959,000	
Estimated Total Capital Cost	\$ 31,157,000	

Spec. Division / Item	Size	Units	Quantity	Unit	Unit Cost	Total Cost	Notes
2 - Sitework						\$ 7,648,000	
Mobilization/Demobilization			\$18,155,000		10%	\$ 1,816,000	
Sitework Allowance			1	LS	\$ 100,000	\$ 100,000	
MF Feed Pipeline	12	in	500	LF	\$ 195	\$ 98,000	
Excavation for Equalization			750	CY	\$ 33	\$ 25,000	2' over excavation
Excavation for Pads			580	CY	\$ 33	\$ 19,000	3' depth
Offhaul			1,400	CY	\$ 10	\$ 14,000	Assumes all excavation is offhauled
Dewatering							
Structural Piles							
Landscaping Allowance			1	LS	\$ 25,000	\$ 25,000	
4" Pipe, MF Backwash	4	in	500	LF	\$ 123	\$ 62,000	
4" Pipe, RO Concentrate	4	in	500	LF	\$ 123	\$ 62,000	
RW Distribution Pipe	8	in	26,500	LF	\$ 205	\$ 5,427,000	
3 - Concrete						\$ 292,000	
Secondary EQ/MF Influent PS Slab			170	CY	\$ 800	\$ 136,000	18 in thick, 12 inch thick
Treatment Building Slab			150	CY	\$ 800	\$ 120,000	12 in thick
UV System Slab			0	CY	\$ 800	\$ -	included in Treatment building
Chemical Storage Slab			26	CY	\$ 800	\$ 21,000	12 in thick
RW Tank/PS Slab			19	CY	\$ 800	\$ 15,000	12 in thick

Spec. Division / Item	Size	Units	Quantity	Unit	Unit Cost	Total Cost	Notes
4 - Masonry						\$ 196,000	
CMU Blocks			5,610	SF	\$ 35	\$ 196,000	15 ft height
5 - Metals						\$ 95,000	
CMU Building Roofing			6,390	SF	\$ 15	\$ 95,000	Treatment Building
11 - Equipment						\$ 6,819,000	
MF Feed Pumps							Included in vendor package
MF System	0.6	MGD	1	LS	\$ 863,000	\$ 863,000	AWC Quote (9/28/2018)
RO System	0.5	MGD	1	LS	\$ 175,000	\$ 175,000	TrojanUV Quote (7/19/2018)
UV System	0.5	MGD	1	LS	\$ 1,038,000	\$ 519,000	50% of equipment cost
Treatment Equipment Installation			50%	LS	\$ 100,000	\$ 100,000	
Chemical Allowance			1	LS	\$ 56,000	\$ 112,000	1 duty + 1 standby
RW Pumps	50	hp	2	EA	\$ 50,000	\$ 50,000	
Pump Install			1	LS	\$ 1,000,000	\$ 4,000,000	
Injection Wells			4	EA	\$ 250,000	\$ 1,000,000	
Monitoring Wells			4	EA			
13 - Special Construction						\$ 829,000	
RW Storage			1	EA	\$ 329,000	\$ 329,000	200,000 gallons, Means
Hwy 101 Crossing			1	LS	\$ 500,000	\$ 500,000	
15 - Mechanical						\$ 1,364,000	
Piping, Valve, Fitting, Supports Allowance			Allowance		20%	\$ 1,364,000	20% of Division 11 (Equipment)
16 - Electrical						\$ 1,364,000	
Electrical Allowance					20%	\$ 1,364,000	20% of Division 11 (Equipment)
17 - I&C						\$ 1,364,000	
I&C Allowance			Allowance		20%	\$ 1,364,000	20% of Division 11 (Equipment)
ANNUAL O&M COSTS			Amount	Unit	Value	Cost	
Consumables					Total Consumables	\$ 250,000	
Equipment Consumables			\$ 6,819,000		2%	\$ 137,000	2% of Equipment
Electrical Consumables			\$ 1,364,000		2%	\$ 28,000	2% of Electrical
Instrumentation Consumables			\$ 1,364,000		2%	\$ 28,000	2% of Instrumentation
Pipeline Consumables			\$ 5,649,000		1%	\$ 57,000	1% of Pipeline
Power Costs					Total Power	\$ 225,000	
Secondary Pumps (MF Feed)			39,300	kwh	\$ 0.18	\$ 7,100	
MF Backwash Pump			72,600	kwh	\$ 0.18	\$ 13,100	
RO High Pressure Pump			862,500	kwh	\$ 0.18	\$ 155,300	
UV System			135,780	kwh	\$ 0.18	\$ 24,500	
RW Distribution Pumps			137,500	kwh	\$ 0.18	\$ 24,800	
Labor Costs					Total Labor	\$ 250,000	
Total # Operators			1.0	FTE			
Average Annual Hours per operator			2080	hrs/yr			
Total Operators per year			2080	Total hrs	\$ 120	\$ 250,000	
TOTAL ANNUAL O&M COSTS						\$ 725,000	